

INDUSTRIAL UPS SYSTEM 5 kVA up to 60 kVA

The La Marche Industrial Uninterrupted Power System (IUPS) is designed based on pulse width modulation (SPWM) rectifier and inverter using fully digital DSP+ IGBT technology. This transformer-based double-conversion IUPS is highly robust, well-proven and provides the highest level of flexibility. This transformer-based IUPS incorporates the latest designs and operates at high efficiency while providing galvanic isolation. For Three Phase units, the 12-pulse rectifier section generates very low total harmonic current distortion (THD) under 5% improving input power factor. The low AC ripple currents in DC voltage along with a battery test feature improves battery life and availability. The IUPS is designed with an output transformer, allowing flexibility where bypass voltage and rectifier input voltage can be from a separate source.

The built-in Static Switch using power SCRs provide instantaneous transfers (less than 4ms) to an alternate source if any disturbance occurs at the UPS input. The highly reliable IUPS is the preferred choice in mission-critical applications and high-power data centers compared to transformer-free UPS technology.

The La Marche IUPS is equipped with a dynamic real-time Touch-Screen mimic panel displaying power flow, voltages and currents, alarms and status, data logging, and user-friendly password protected configuration capabilities.

The IUPS is highly customizable; kVA rating, Input/Output Voltages, Charger Sizing, enclosure protection ratings, distribution, isolation bypass transformer, distribution, and many more.



Shown Above:
IUPS-15KVA, IUPS-40KVA and IUPS-60KVA

Standard Features

- IGBT - SPWM Technology
- Input and Output Isolation Transformer
- Hybrid Design of 12 Pulse Rectification & IGBT Regulation
- 7" Touch Display
- Mimic Panel and Keyboard
- Battery Test
- Web Based Monitoring (Ethernet Port)
- 16 Dry Alarm Contacts
- Data Logging
- Static Bypass Switch
- Battery Temperature Compensation (adjustable rate)
- Real Time Clock
- Input, Battery, Bypass and Inverter Output Circuit Breakers
- IP20 Rated Enclosure
- UL 1778

Optional Features

- External Manual Bypass Switch
- External Bypass Isolation Transformer
- Emergency Power OFF (EPO)
- Additional IP Rated Enclosures

Communication Protocols

- 21J** IEC 61850 Ethernet
- 21P** DNP 3.0 Communications RS232/RS485/Ethernet
- 21Q** Modbus Communications RS232/RS485/Ethernet
- 21S** Modbus RTU RS232/RS485
- 21X** SNMP and Web Browser (Ethernet)

Specifications

UPS INPUT	UPS kVA Rating	(Up to 60) kVA
	AC Input Voltage	3 Phase: 380Vac, 400Vac, 415Vac & 480Vac 1 Phase: 120Vac, 208Vac, 220Vac, 230Vac & 240Vac
	AC Input Range	-12% / +10%
	Input Frequency	50Hz or 60Hz ($\pm 5\%$)
UPS OUTPUT	AC Output Voltage	1 Phase: 120Vac, 208Vac, 220Vac, 230Vac & 240Vac Split Phase: 120/240Vac (2Ph, 3W)
	Output Voltage Regulation	$\pm 1\%$
	Output Frequency	60Hz $\pm 0.1\%$ (50Hz Available)
	Frequency Stability	Free Running $\pm 0.1\%$ Mains sync $\pm 3\%$
	Total Harmonic Distortion	Linear load: $< 5\%$ Non-linear load: $\leq 7\%$ (non linear load defined by IEC 62040)
	Efficiency	AC-AC = 82% DC-AC = 89%
	Inverter Overload Capacity	105% for 60mins 125% for 10mins 150% for 1 min >150% for 200mS
	Load Power Factor	0.8 lagging to 0.8 leading
	Output Crest Factor Admissible	3:1
	DC LINK	DC Voltage
DC Voltage Range		(96-150)Vdc (192-300)Vdc
Inverter DC Input Voltage Range		-20% / 18%
Rectifier Output Voltage Line/Load Regulation		$< 1\%$
Rectifier Output Voltage Ripple		$< 2\%$
Battery Charger Capacity		110% of system capacity (higher capacity charger available on request)
STATIC SWITCH	kVA Rating	125% of System Rating
	Transfer Time	$< 4\text{mS}$
	Overload Capacity	125% for Continuous 150% for 10 minutes 200% for 1 minutes 1000% for 1 cycle
MANUAL BYPASS	Switch Type	Rotary Switch (3 Positions - UPS, Test and Bypass)
	Switching	Make Before Break
PROTECTION	Protection	Input Under Voltage, Input Over Voltage, Output Under Voltage, Output Over Voltage, Battery Over Charging, Input in Rush Current Protection by soft start as well as pre-charge circuit, Output Over Load, Battery Under Voltage, DC Over Voltage, Output Short Circuit
ENVIRONMENTAL	Ambient Temperature	0° to 40°C (32° to 104°F)
	Relative Humidity	0-95% non-condensing
	Operating Altitude	Up to 1000 meters without derating the output
	Noise Level	65-70 dBA @ 1 meter
MECHANICAL	Enclosure Color	RAL 7035 or as Requested
	Cooling	Fan Assisted (Temperature Dependent)
	External Protection	IP20 as standard (others available upon request)
	Dimensions	According to ratings and options
	Compliance	UL 1778 NEMA PE1 IEC 62040 -1 / -2 / -3 FCC Part 15 Class A

Model Number Chart

SINGLE PHASE INPUT																
Model Number	kVA Rating	Phase	UPS Output / Bypass Input						AC Input					DC Bus		
			Output Current (A) @ Output Volts (V)				Freq. (Hz)	Phase	Input Current (A) @ Input Volts (V)			Freq. (Hz)	Voltage (Vdc)	Rectifier Capacity (A)	Inverter Input Current (A)	
			120	208	220	240			208	220	240					
125 Vdc	IUPS-5K	5	1PH	41.7	24	28.8	20	60	1PH	67	63.3	58	60	125	60	56.1
	IUPS-10K	10	1PH	83.4	48.1	45	42.7	60	1PH	133.9	126.6	116	60	125	120	112.1
	IUPS-15K	15	1PH	125	72.2	68.2	62.5	60	1PH	200.8	189.8	174	60	125	180	168.1
250 Vdc	IUPS-5K	5	1PH	41.7	24.1	22.8	20.9	60	1PH	67	63.3	58	60	250	30	28.1
	IUPS-10K	10	1PH	83.4	48.1	45.5	41.7	60	1PH	133.9	126.6	116	60	250	60	56.1
	IUPS-15K	15	1PH	125	72.2	68.2	62.5	60	1PH	200.8	189.8	174	60	250	90	84.1

THREE PHASE INPUT																	
Model Number	kVA Rating	Phase	UPS Output / Bypass Input						AC Input					DC Bus			
			Output Current (A) @ Output Volts (V)				Freq. (Hz)	Phase	Input Current (A) @ Input Volts (V)				Freq. (Hz)	Voltage (Vdc)	Rectifier Capacity (A)	Inverter Input Current (A)	
			120	208	220	240			208	380	415	480					
125 Vdc	IUPS-5K	5	1PH	41.7	24.1	22.8	20.9	60	3PH	27.8	15.2	14	12.1	60	125	60	53.6
	IUPS-10K	10	1PH	83.4	48.1	45.5	41.7	60	3PH	55.6	30.4	27.9	24.1	60	125	120	107.1
	IUPS-15K	15	1PH	125	72.2	68.2	62.5	60	3PH	83.3	45.6	41.8	36.1	60	125	180	160.6
	IUPS-20K	20	1PH	166.7	96.2	91	83.4	60	3PH	115.7	63.4	58	50.2	60	125	250	214.1
	IUPS-30K	30	1PH	250	144.3	136.4	125	60	3PH	173.5	95	87	75.2	60	125	375	321.1
	IUPS-40K	40	1PH	333.4	192.4	181.9	166.7	60	3PH	231.4	126.7	116	100.3	60	125	500	428.1
250 Vdc	IUPS-5K	5	1PH	41.7	24.1	22.8	20.9	60	3PH	27.8	15.2	14	12.1	60	250	30	26.8
	IUPS-10K	10	1PH	83.4	48.1	45.5	41.7	60	3PH	55.6	30.4	27.9	24.1	60	250	60	53.6
	IUPS-15K	15	1PH	125	72.2	68.2	62.5	60	3PH	83.3	45.6	41.8	36.1	60	250	90	80.3
	IUPS-20K	20	1PH	166.7	96.2	91	83.4	60	3PH	115.7	63.4	58	50.2	60	250	125	107.1
	IUPS-30K	30	1PH	250	144.3	136.4	125	60	3PH	171.2	93.7	85.8	74.2	60	250	185	160.6
	IUPS-40K	40	1PH	333.4	192.4	181.9	166.7	60	3PH	231.4	126.7	116	100.3	60	250	250	214.1
	IUPS-50K	50	1PH	416.7	240.4	227.3	208.4	60	3PH	277.6	152	139.2	120.3	60	250	300	267.6
IUPS-60K	60	1PH	500	288.5	272.8	250	60	3PH	347	190	174	150.4	60	250	375	321.1	

NOTE: Consult Factory for Other Ratings.

System Panel Display

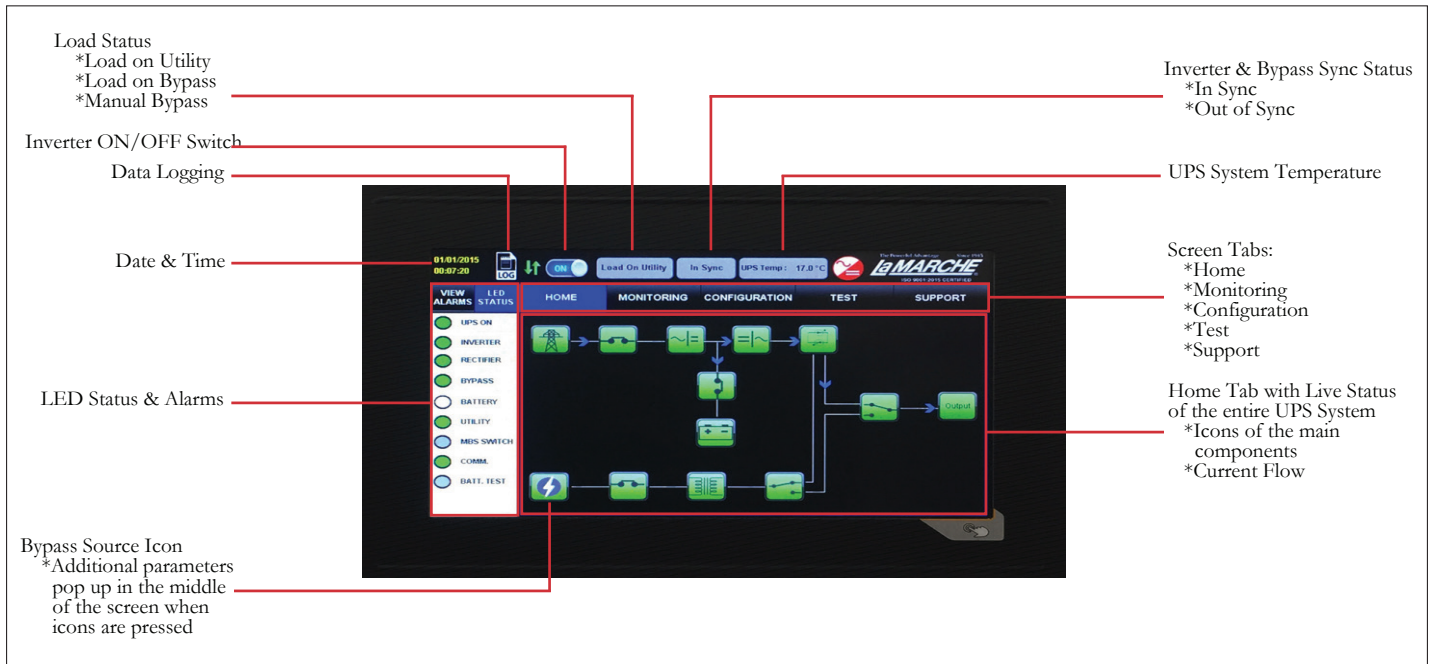

IUPS kVA Rating Based on DC Voltage

DC Voltage	DCV Range	1-Ph Input UPS	3-Ph Input UPS
125Vdc	105Vdc - 150Vdc	Up to 15kVA	Up to 40kVA
250Vdc	220Vdc - 264Vdc	Up to 15kVA	Up to 60kVA

Enclosure Specifications

Rating	Number of Bays	W	D	H	W	D	H	Approx. Weight	
		inches			mm			lbs	kg
5kVA	1	32	36	82	812.8	914.4	2082	1270	576.0
10kVA	1	32	36	82	812.8	914.4	2082	1435	650.9
15kVA	1	32	36	82	812.8	914.4	2082	1590	721.2
20kVA	1	32	36	82	812.8	914.4	2082	1880	852.7
30kVA	2	64	36	82	1625.6	914.4	2082	2315	1050.0
40kVA	2	64	36	82	1625.6	914.4	2082	2650	1202.0
50kVA	2	64	36	82	1625.6	914.4	2082	3300	1496.8
60kVA	3	96	36	82	2438.4	914.4	2082	3900	1769.0

Manual Bypass Switch Configuration

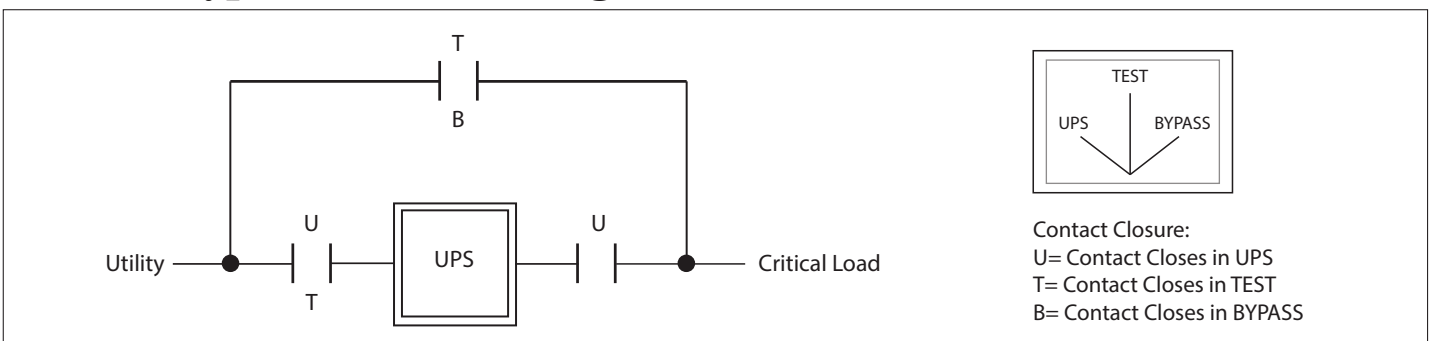

IUPS Block Diagram - Standard

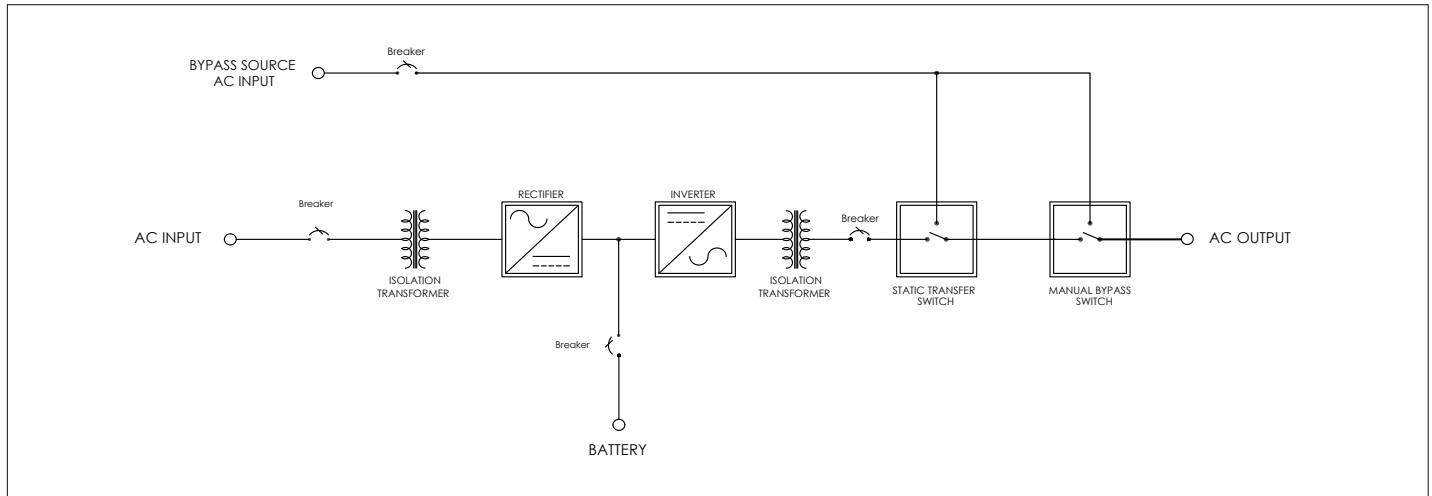

IUPS Block Diagram - with optional External Bypass Transformer & External MBS

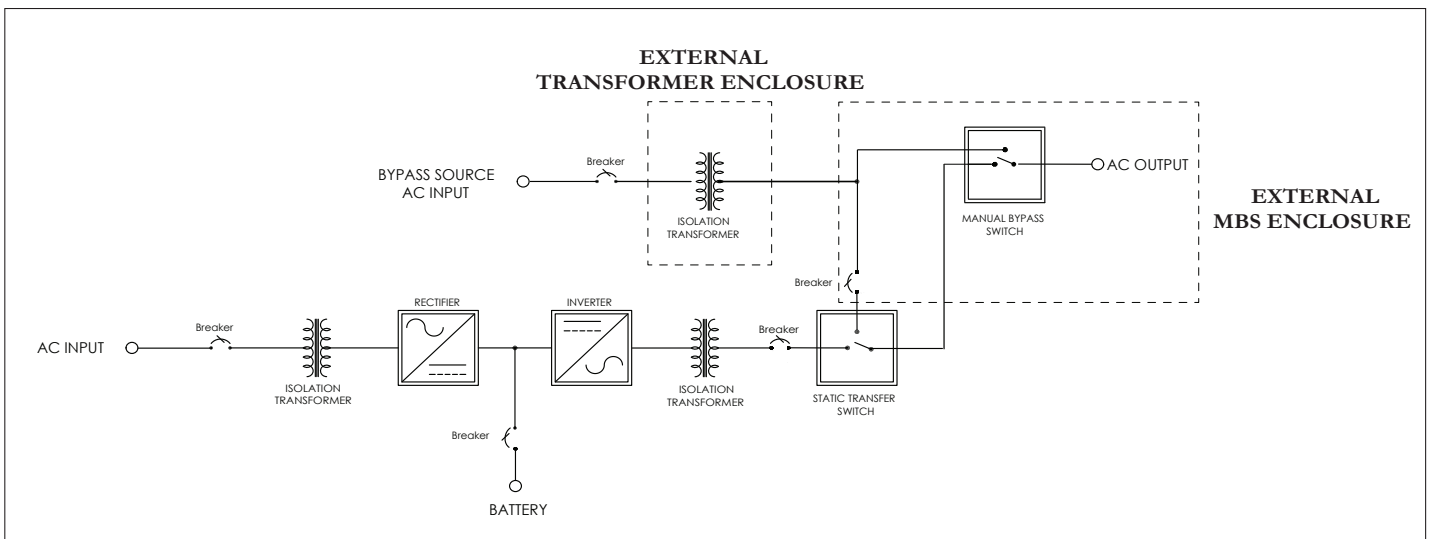

Model Number Nomenclature

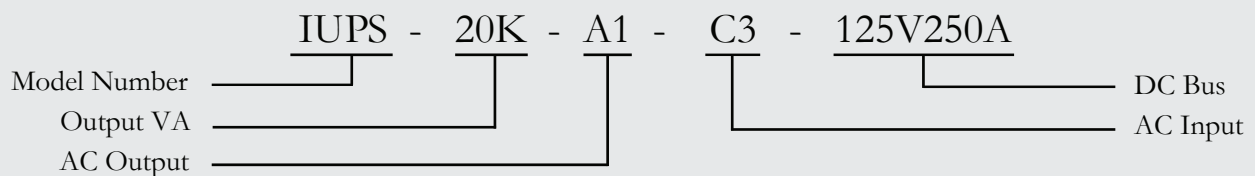

Output VA

5K 30K
10K 40K
15K 50K
20K 60K

AC Output

A1 - 120V (1PH)
B1 - 240V (1PH)
D1 - 208V (1PH)
L1 - 220V (1PH)
Q1 - 230V (1PH)
A1B1 - 120/240V (2PH)

AC Input

A1 - 120V (1PH)
B1 - 240V (1PH)
D1 - 208V (1PH)
L1 - 220V (1PH)
Q1 - 230V (1PH)
C3 - 480V (3PH)
D3 - 208V (3PH)
G3 - 380V (3PH)
J3 - 415V (3PH)

DC Bus

$\frac{xxxVxxx A}{}$
125 Volt 60-500 Amp
250 Volt