

#10 CASE

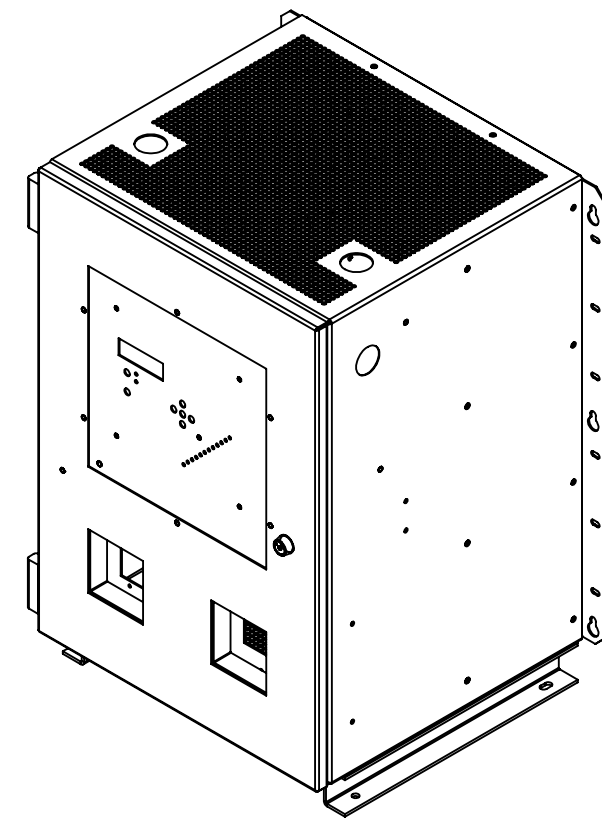

#477 CASE

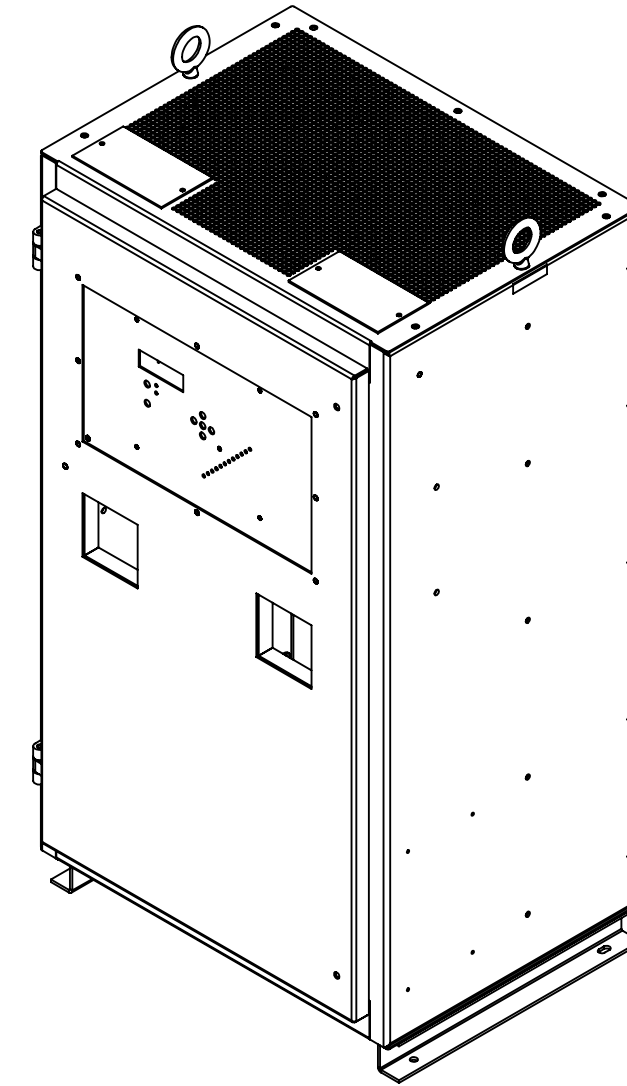

#977 CASE

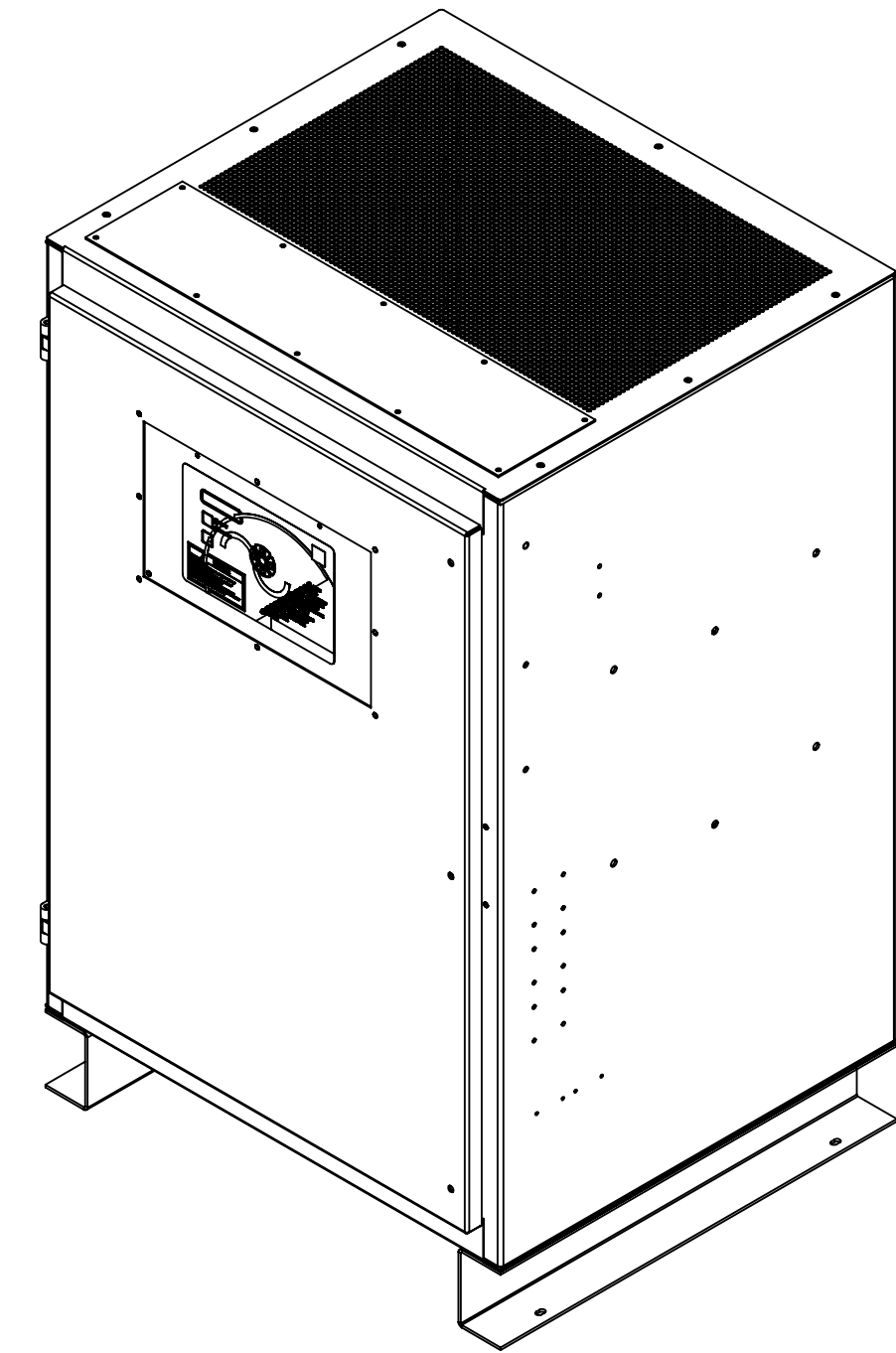

#72N CASE

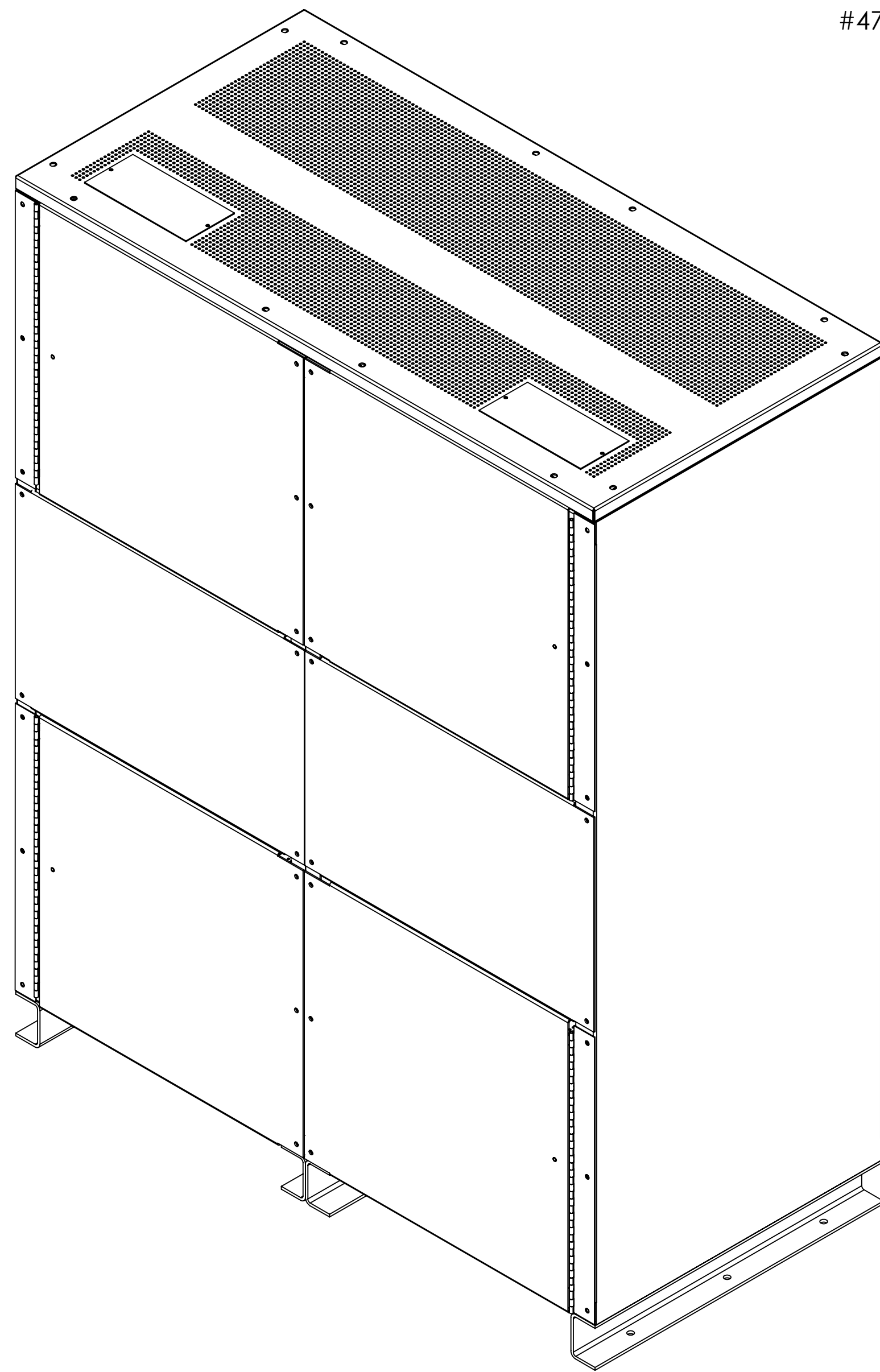

#57N CASE

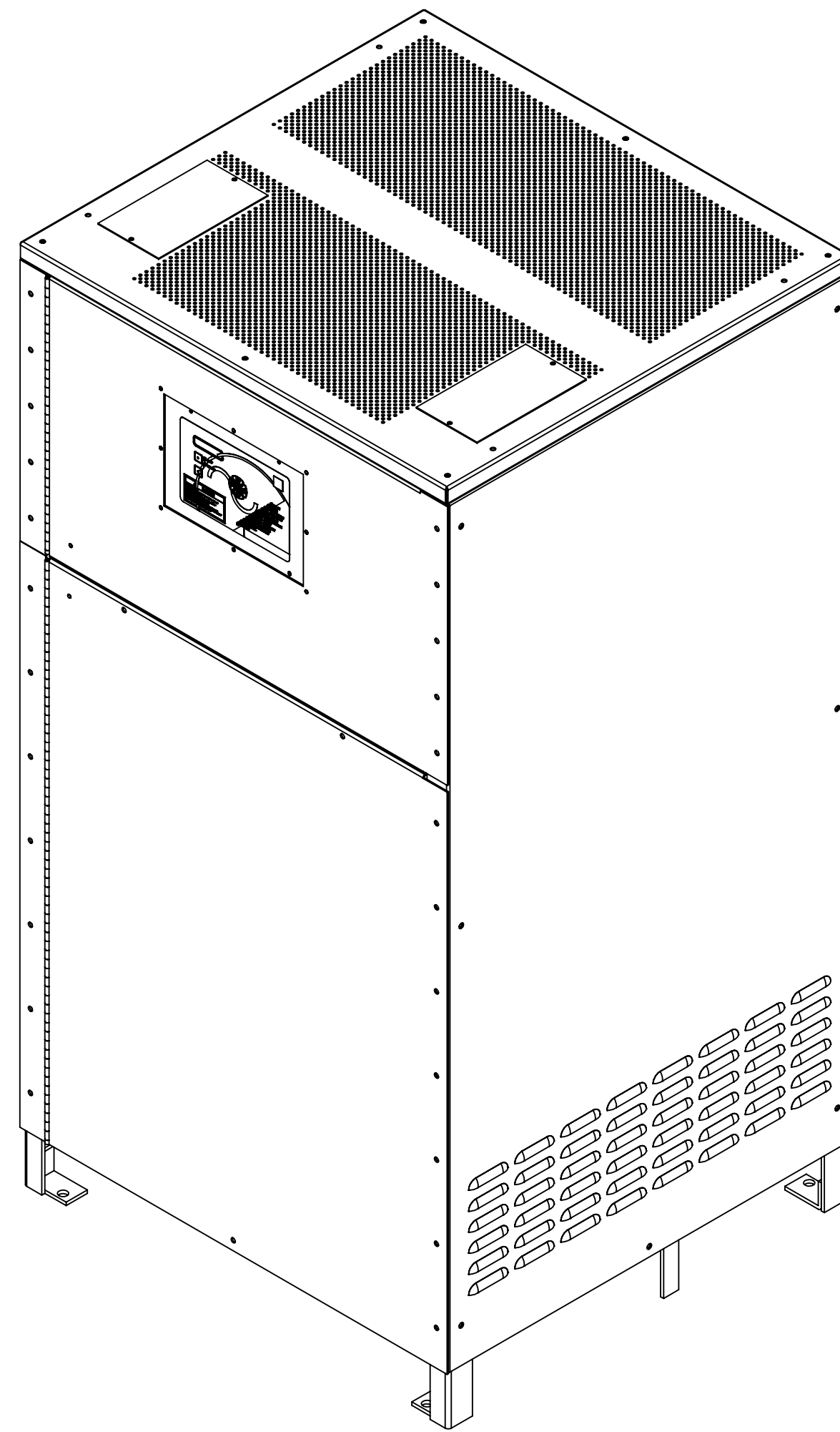

#47N CASE

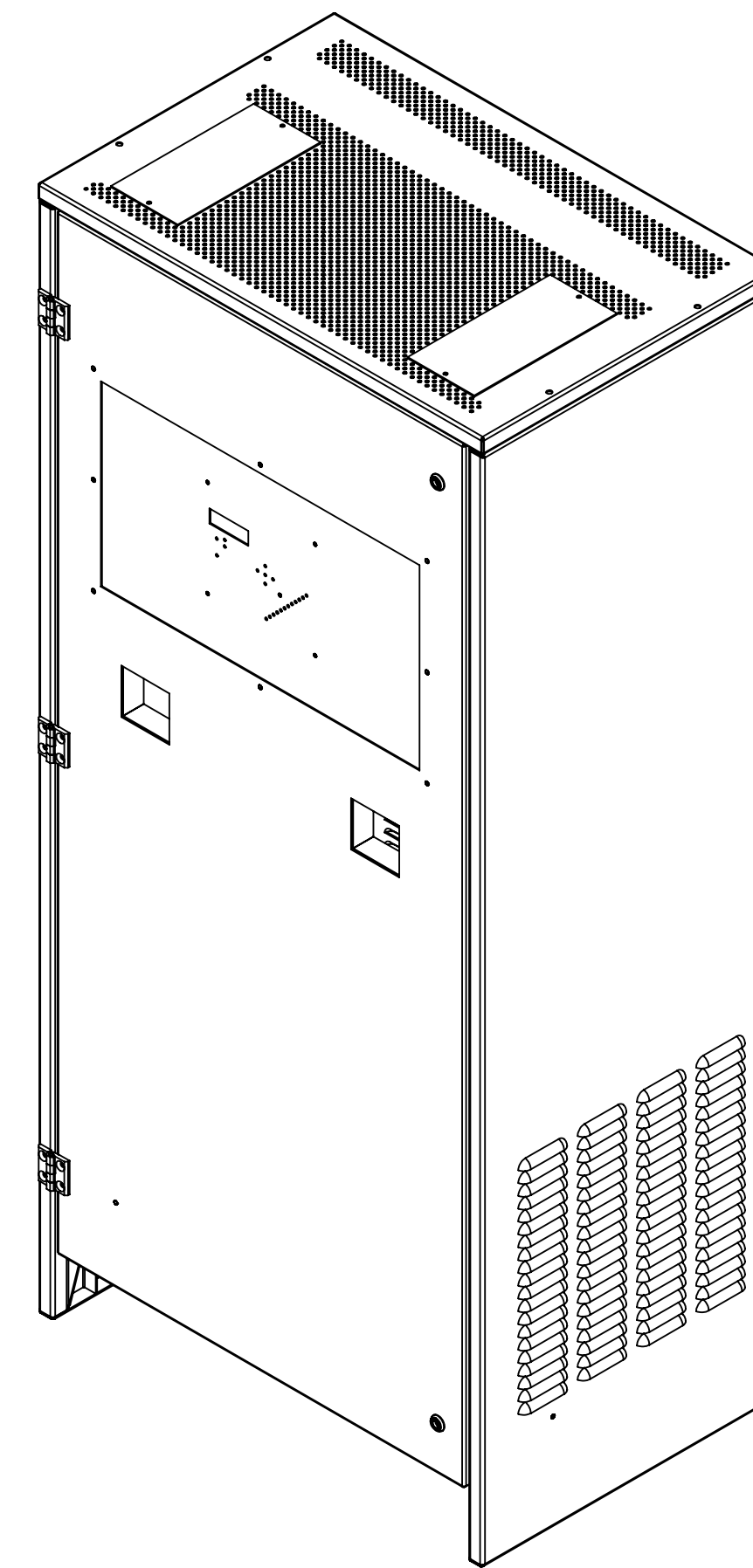

#46N CASE

UNLESS OTHERWISE SPECIFIED: DIMENSIONS ARE IN INCHES TOLERANCES: .XX ± .05 .XXX ± .015 ANGLE: ± 0.5° RADIUS: ± 0.015		 REMOVE ALL BURRS AND BREAK SHARP EDGES .03 MAX.		 SPOT FACE		 106 Bradrock Drive Des Plaines, Illinois 60018 U.S.A. Tel. 847-299-1188 http://www.lamarchemfg.com	
DRWN BY	SBB	ISOMETRIC VIEW A77		ALL POPULAR CASES		DWG NO ALL_A77_CASES	
CHKD BY	TK						
APRVD BY	TK						
DWG DATE	06-04-24						
ISS DATE	06-04-24						
SHEET	1 OF 1	SIZE	D				
SCALE	1:4						
REV	REV DESCRIPTION	BY	CHK	APP	REV DATE	REV ISS DATE	ECN NO

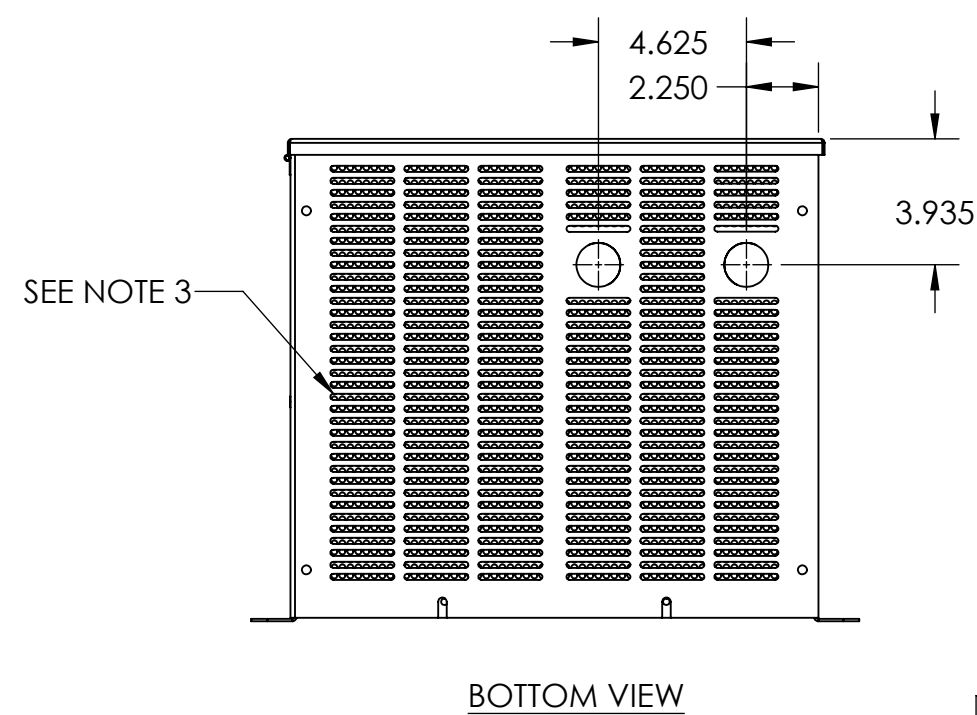
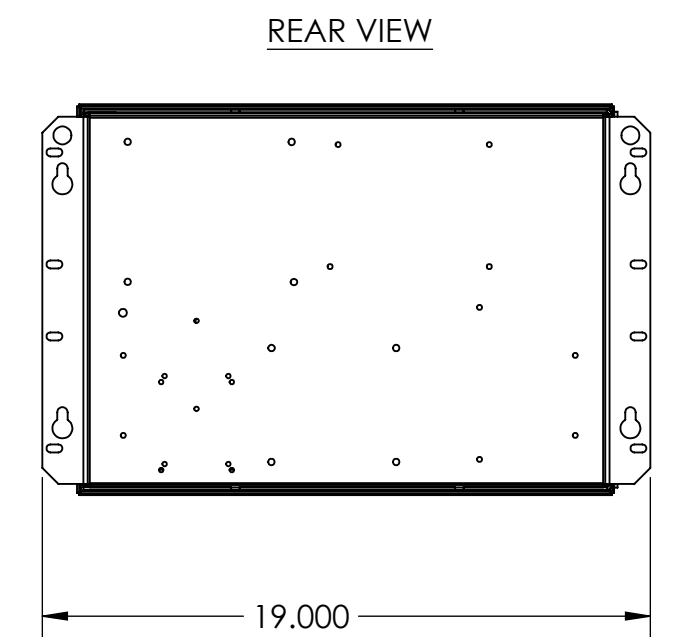
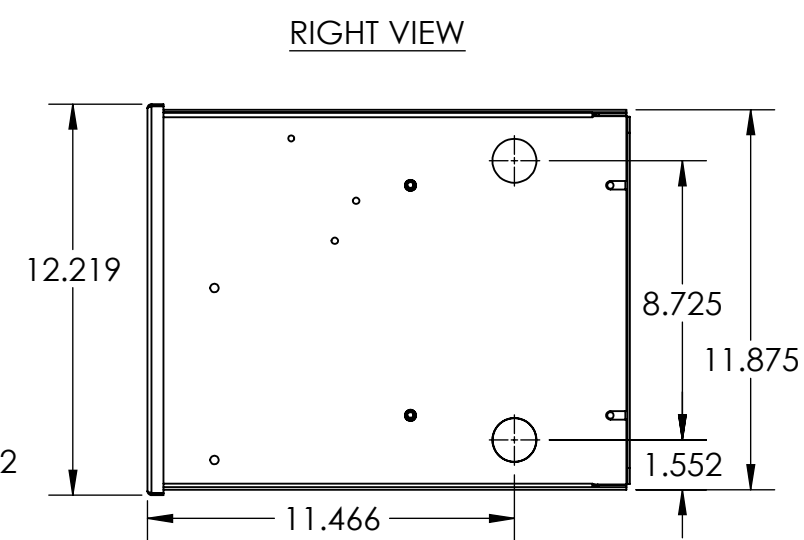
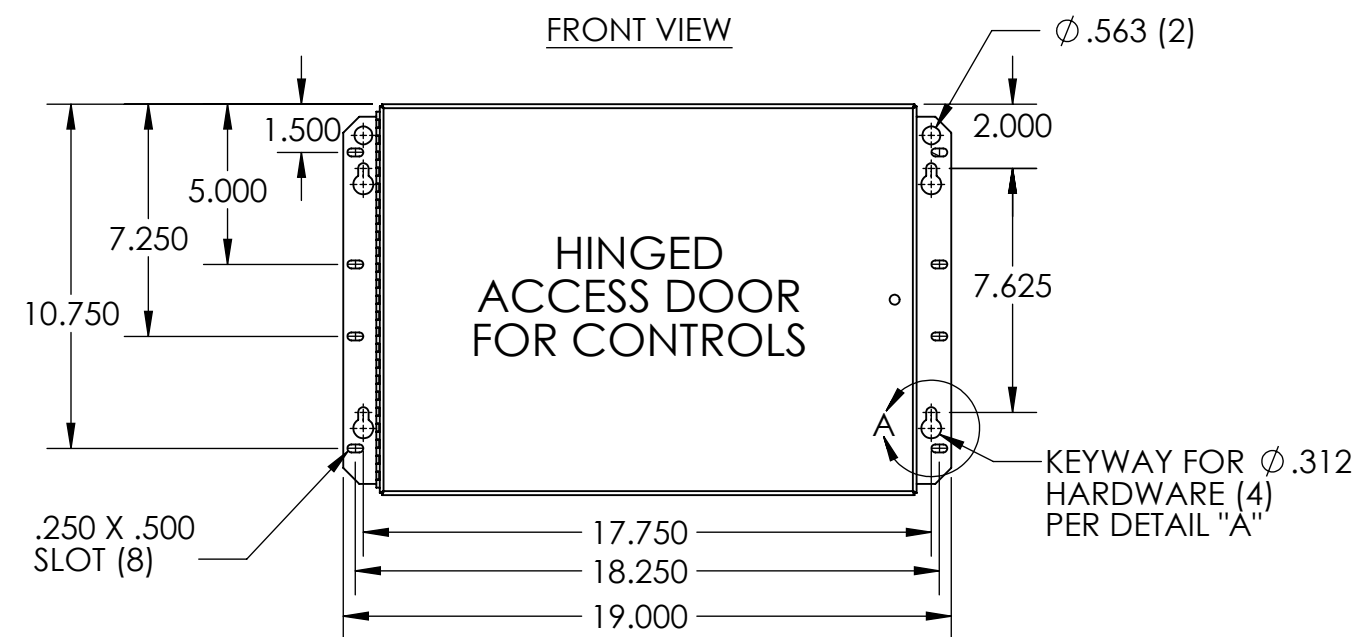
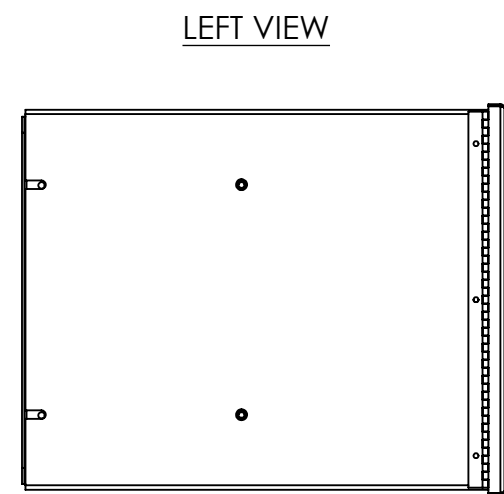
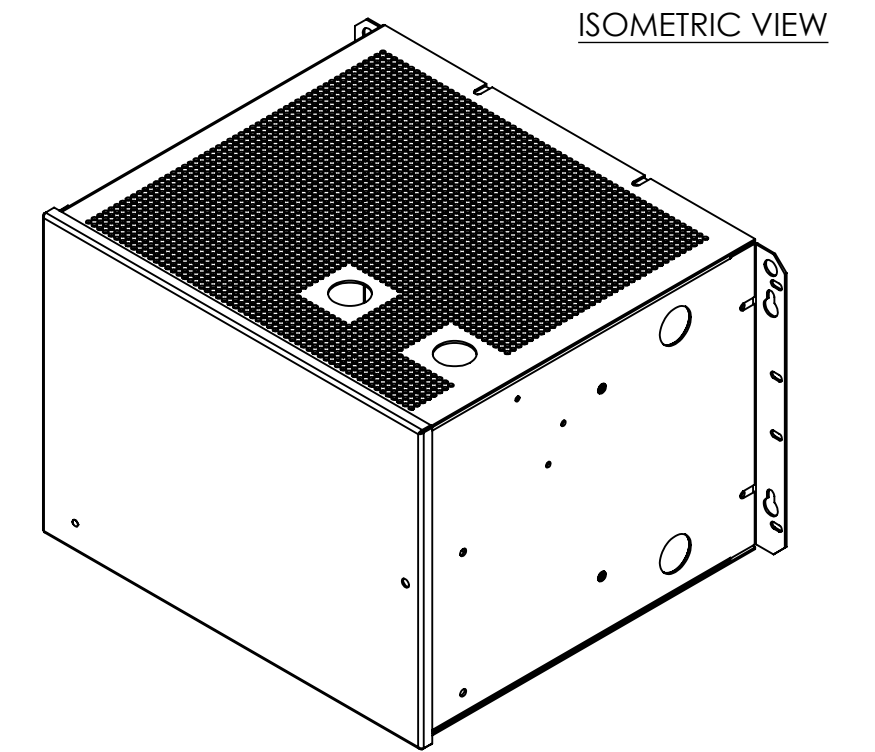
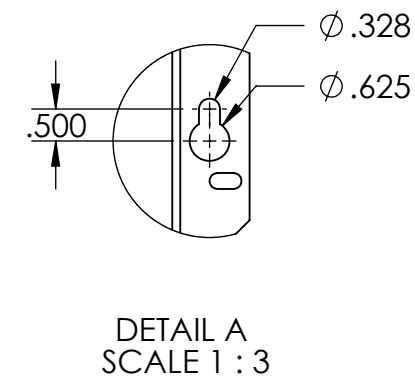
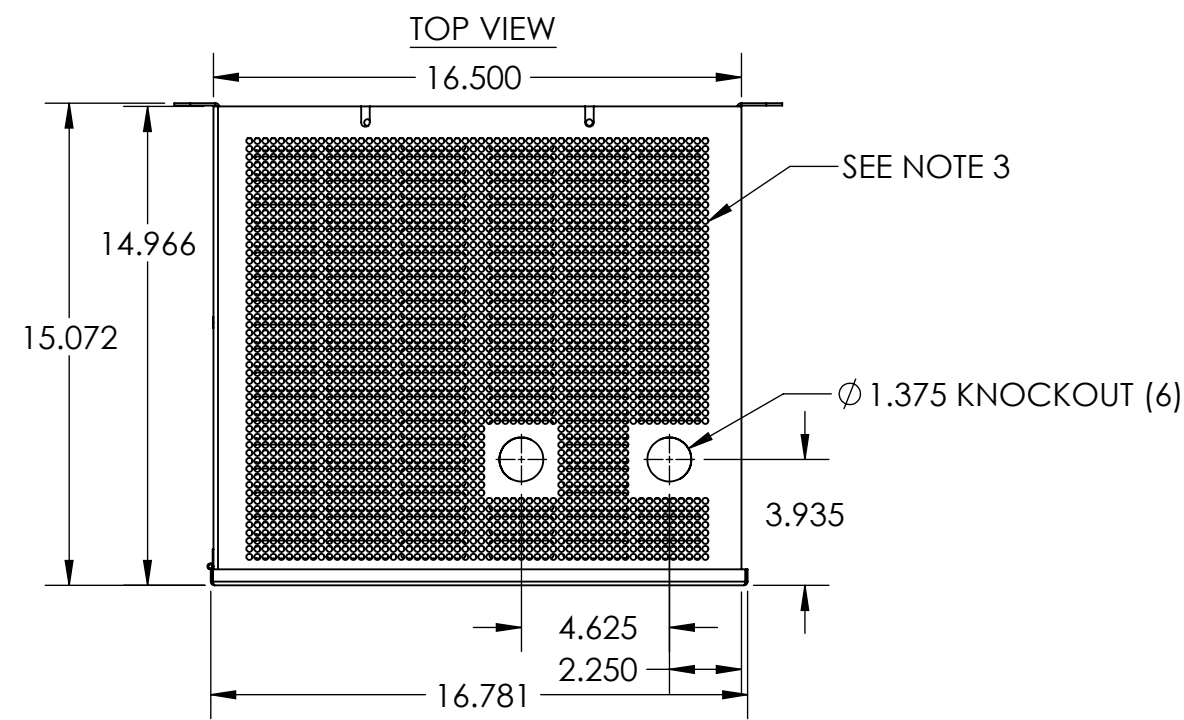

NOTES:

1. MATERIAL:
HOUSING: 14 GAGE SHEET STEEL
DOOR: 16 GAGE SHEET STEEL
BOTTOM PANEL: 16 GAGE SHEET STEEL
BASE: 14 GAGE SHEET STEEL
2. FINISH:
ANSI GREY
3. PERFORATED METAL ON TOP; .188 D. ON .250 CENTERS AND BOTTOM; .188 x 2.00 SLOTS
4. ALL DIMENSIONS GIVEN IN INCHES

MOUNTING DIMENSION OF #10 CASE						
 <small>106 Bradrock Drive Des Plaines, Illinois U.S.A. 60018</small>						
Dwg By	EO	App By	MW	App By	VP	
Dwg Date	02-03-15	Iss Date	04-09-15	Scale	NOTED	
Sheet	1 of 1	Size	C	Dwg No	D10	
Rev Description	By	Chk	App	Rev Date	Rev Iss Date	ECN No

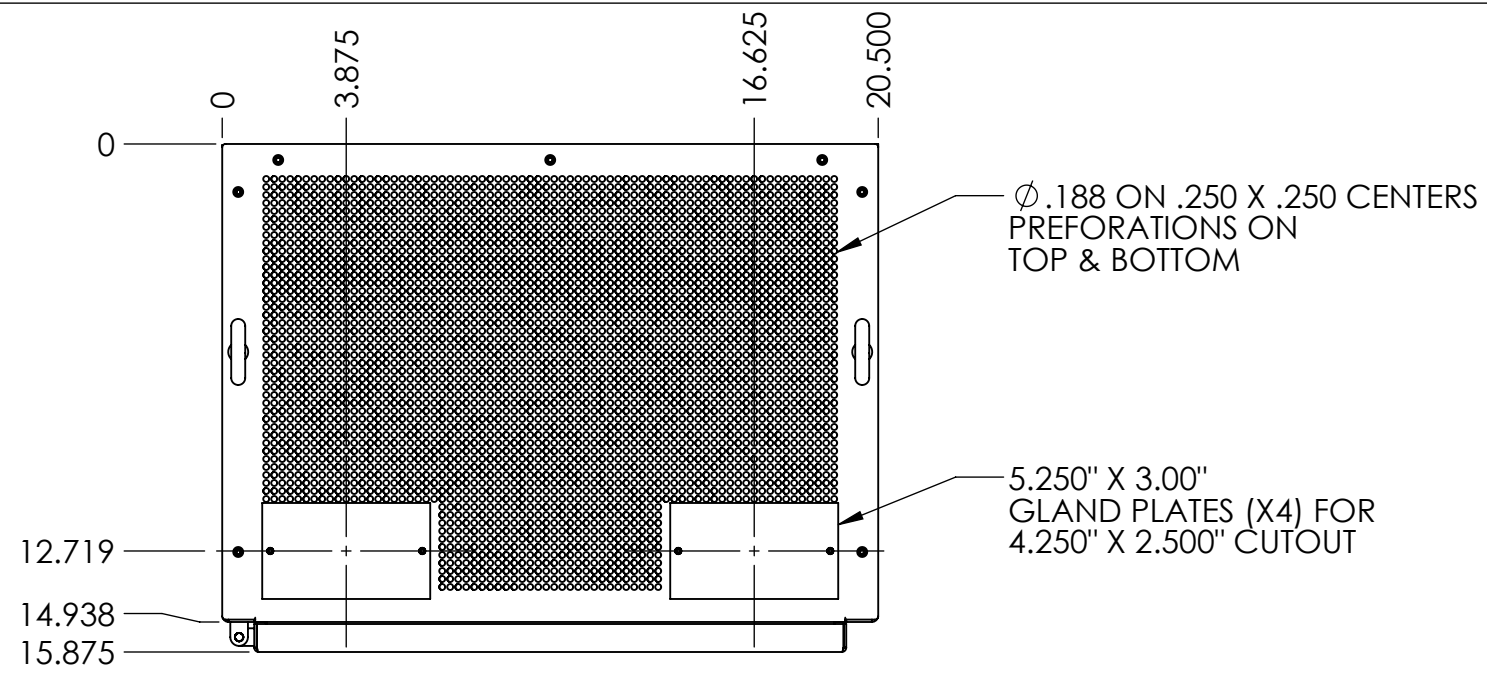

0.500 X 13 SHOULDER EYE BOLT

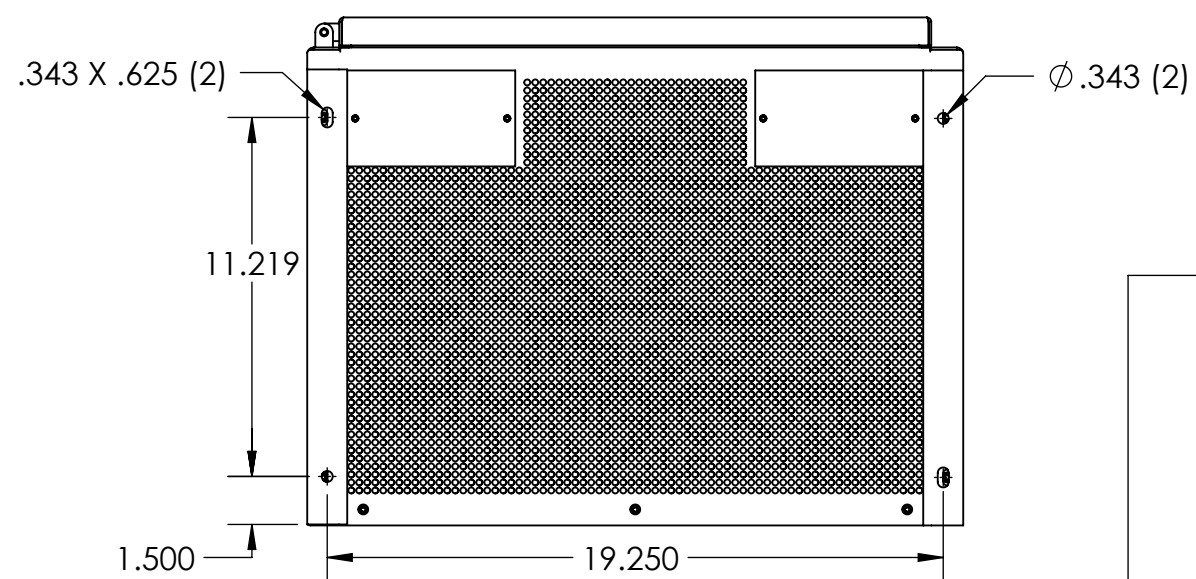
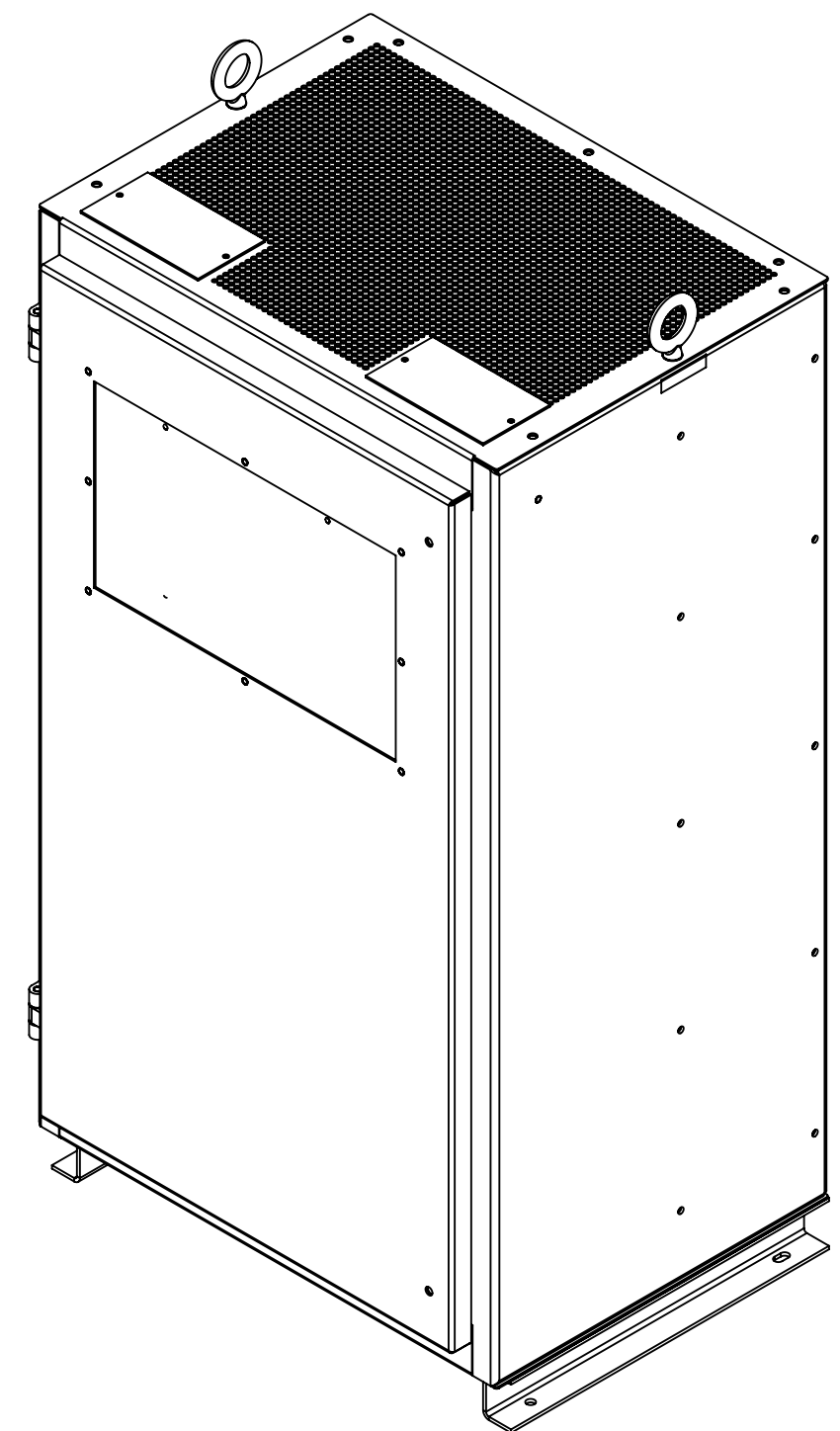
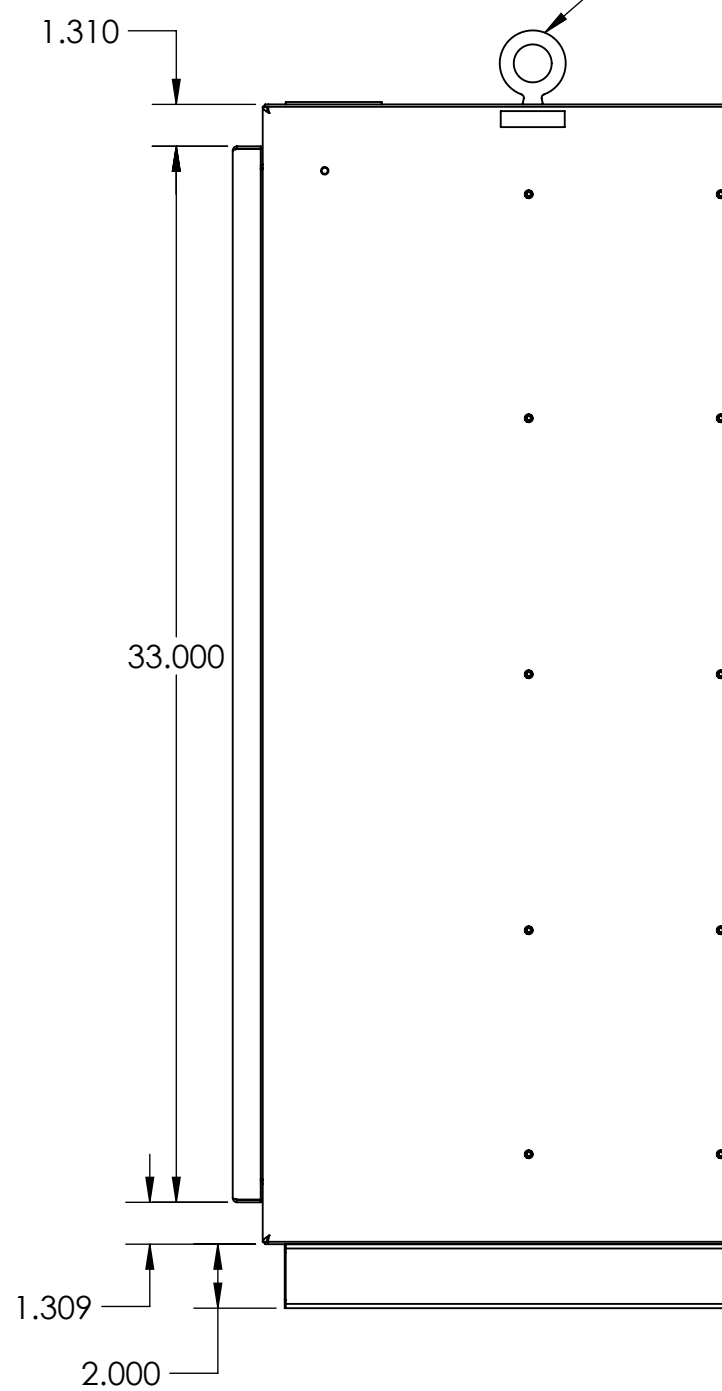
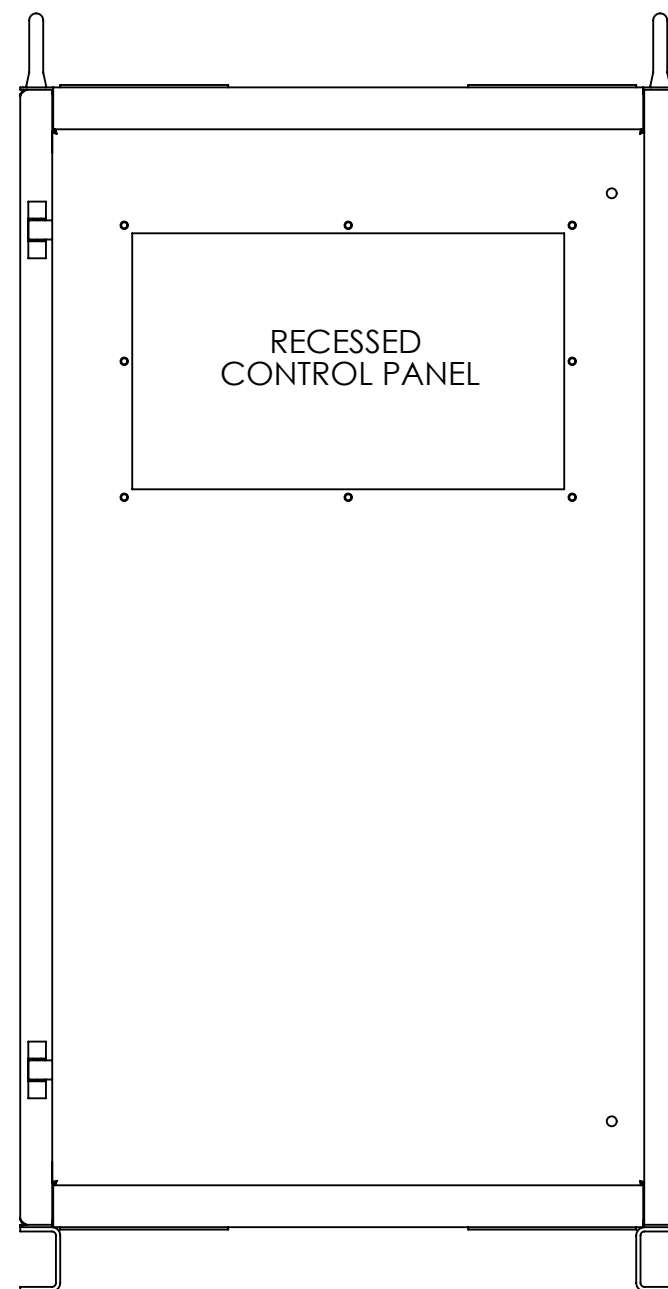
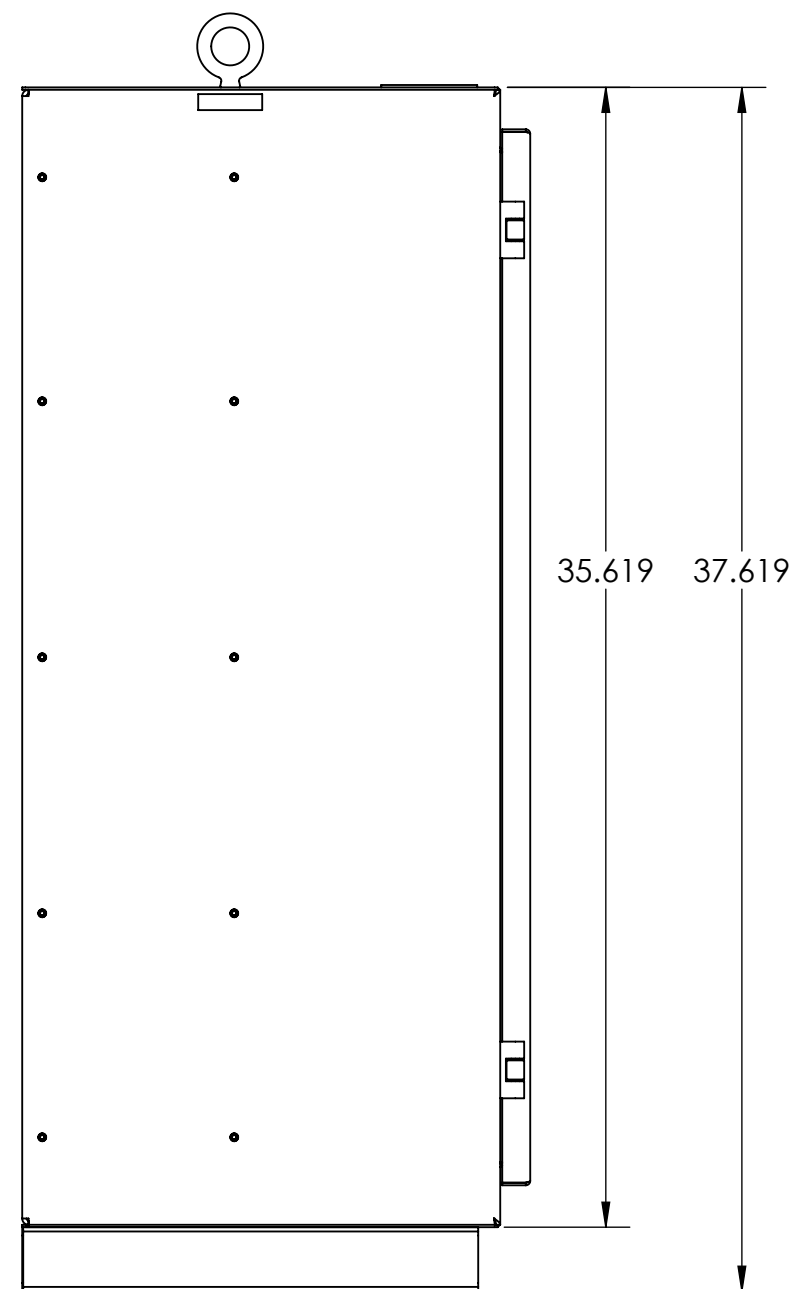

- NOTES:
- HOUSING: 10GA SHEET STEEL
DOOR: 14GA SHEET STEEL
CONTROL PANEL: 16GA SHEET STEEL
TOP: 14GA SHEET STEEL
FLOOR BRACKET: 10 GA. SHEET STEEL
 - FINISH: PAINTED ANSI 61 GRAY
 - ALL DIMENSIONS ARE GIVEN IN INCHES.

MOUNTING DIMENSIONS FOR
#977 CASE



106 Bradrock Drive Des Plaines, Illinois U.S.A. 60018

Dwg By	EO	App By	MW	App By	VP
Dwg Date	01-20-15	Iss Date	01-20-15	Scale	1:6
Sheet	1 of 1	Size	C	Dwg No	D977

Rev Description	By	Chk	App	Rev Date	Rev Iss Date	ECN No

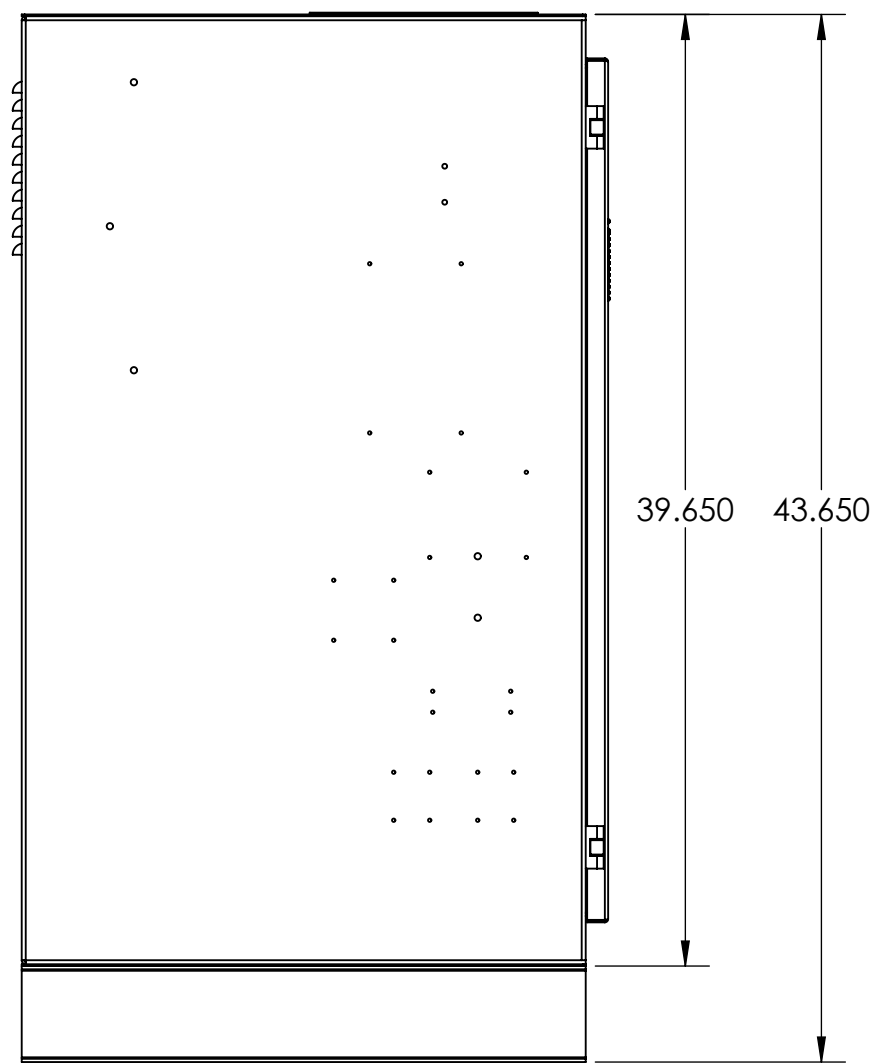
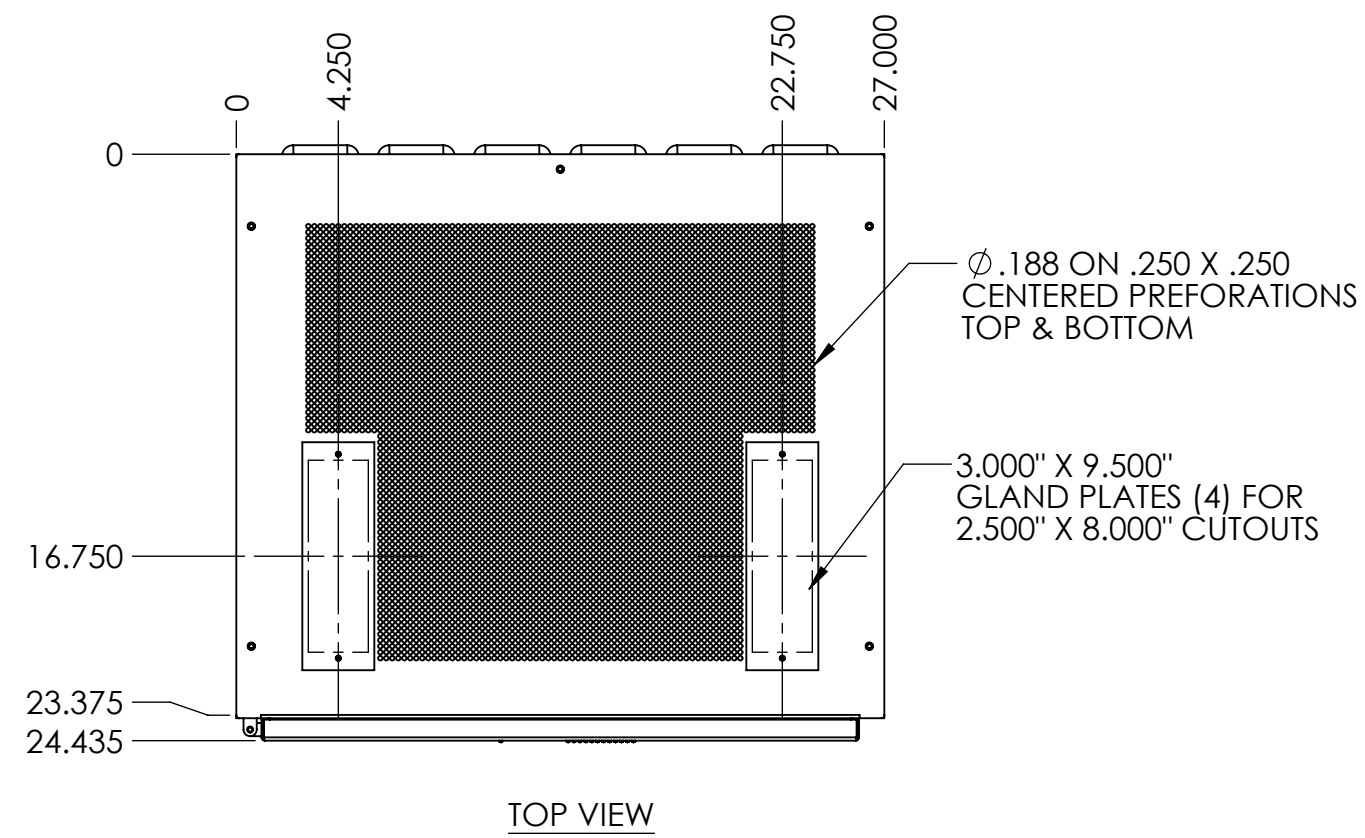

L. SIDE VIEW

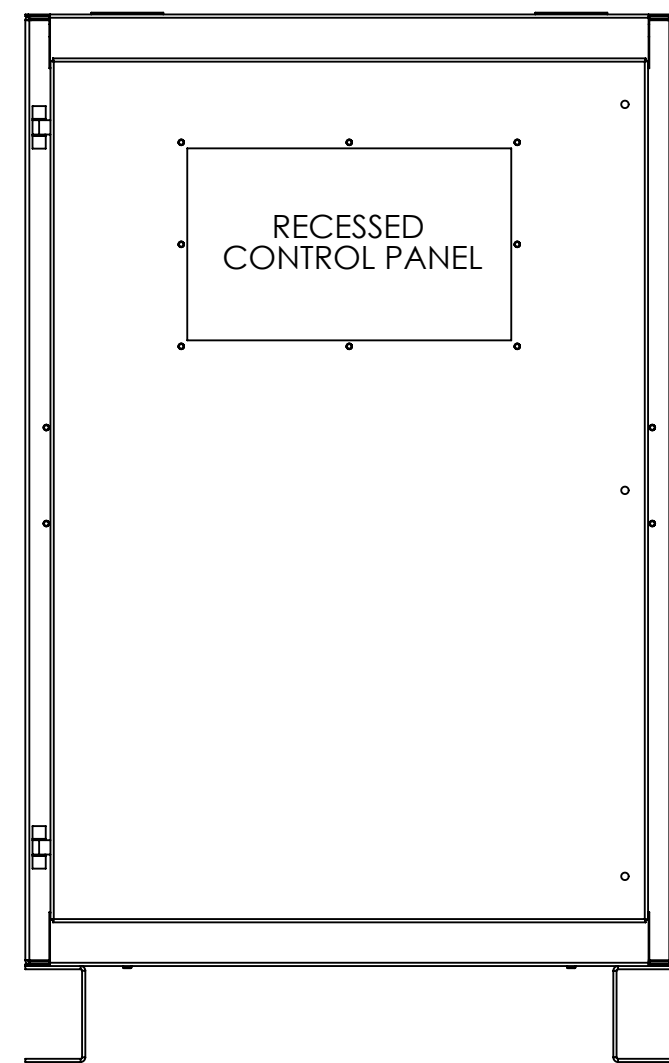

FRONT VIEW

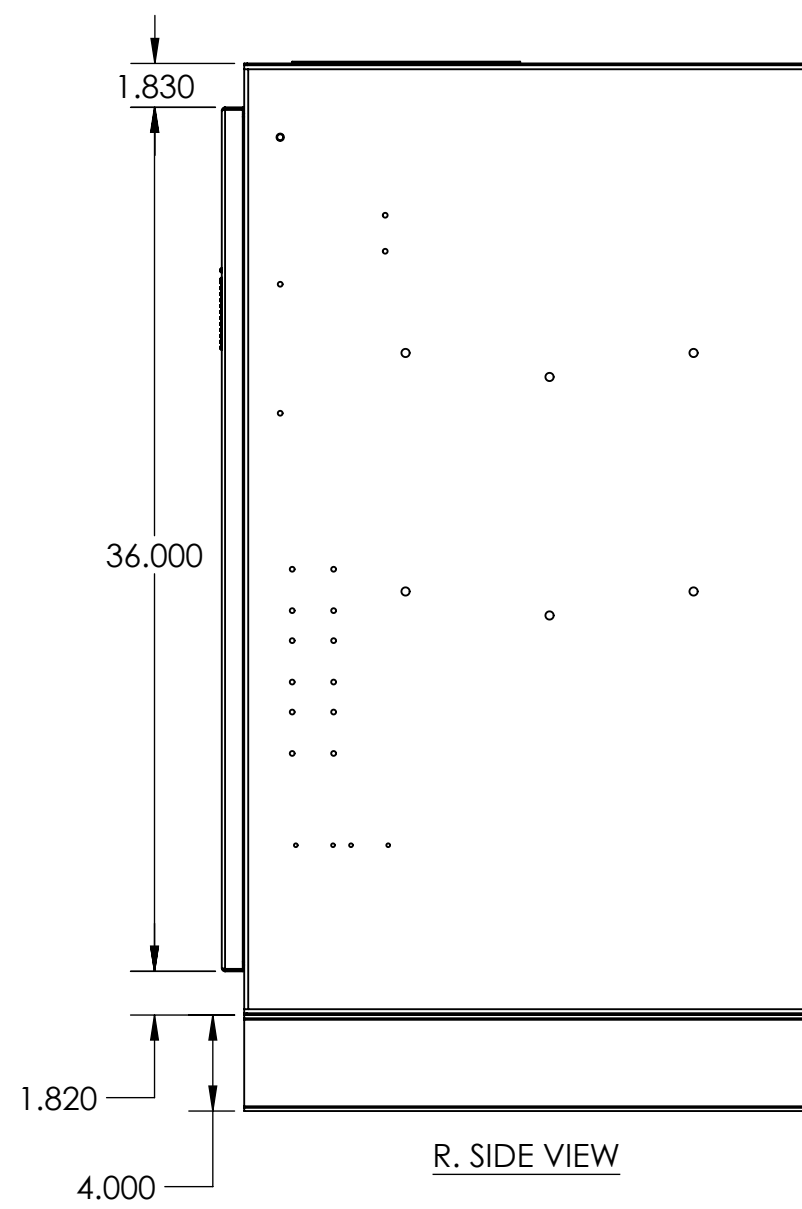

R. SIDE VIEW

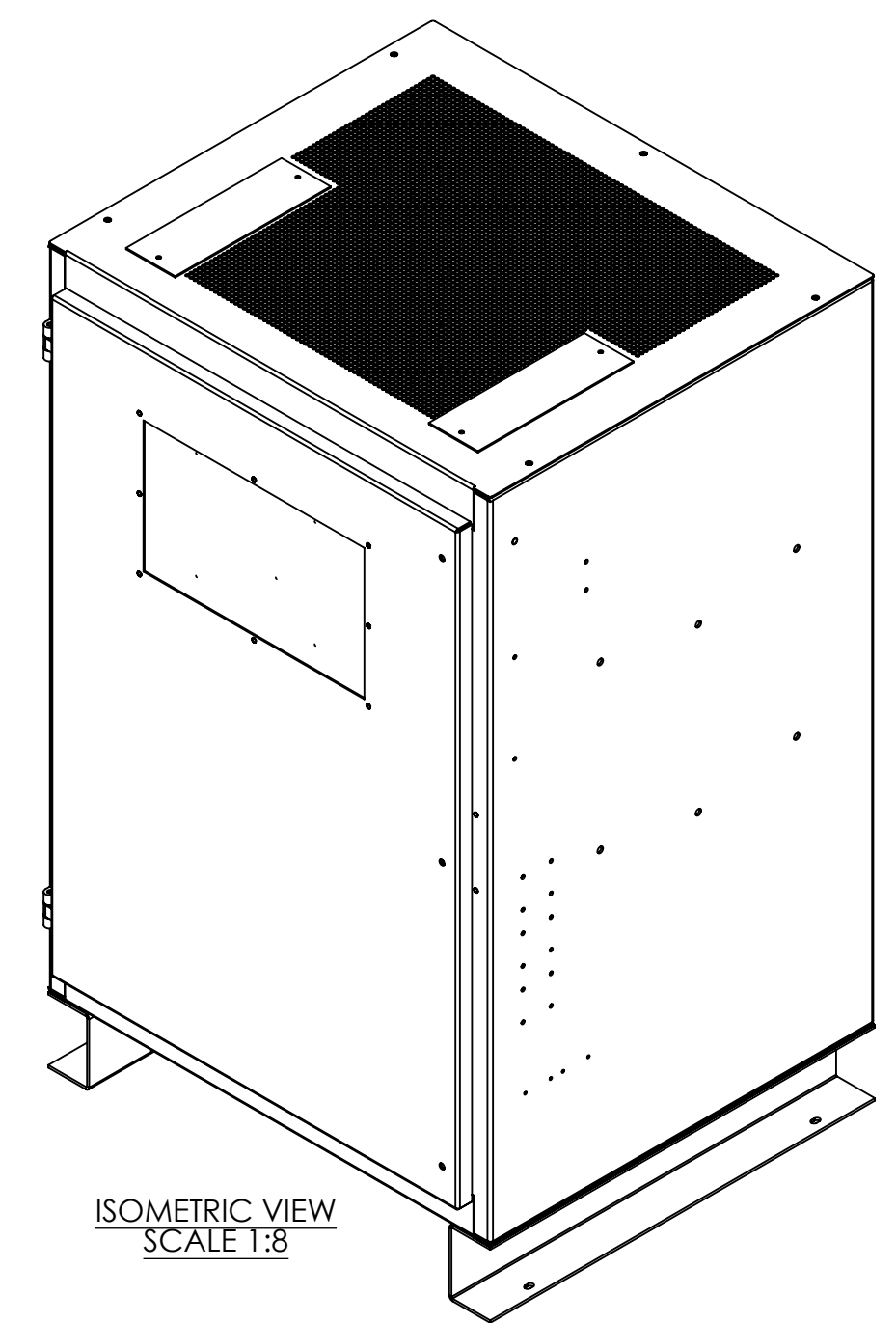

ISOMETRIC VIEW
SCALE 1:8

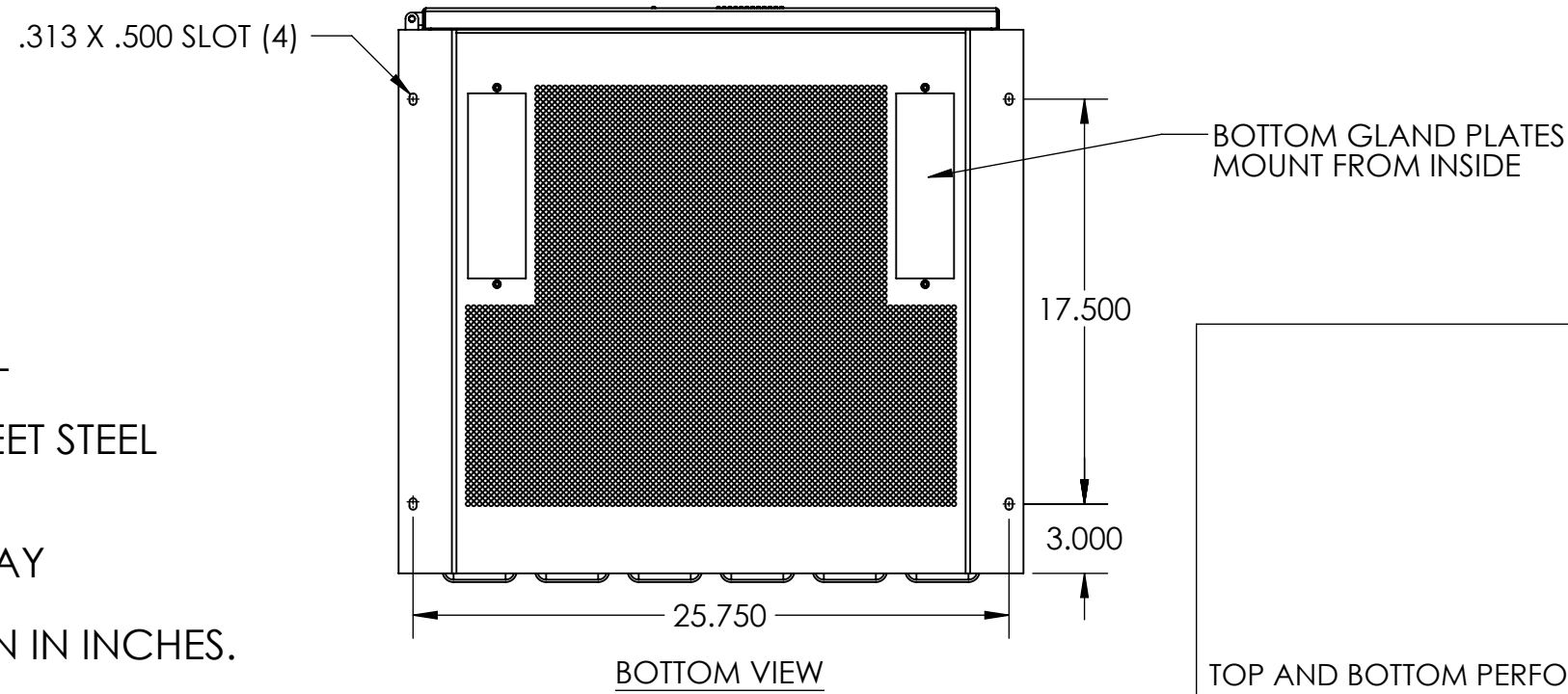

BOTTOM VIEW

- NOTES:
- HOUSING: 12GA SHEET STEEL
DOOR: 14GA SHEET STEEL
CONTROL PANEL: 16GA SHEET STEEL
TOP: 14GA SHEET STEEL
 - FINISH: PAINTED ANSI 61 GRAY
 - ALL DIMENSIONS ARE GIVEN IN INCHES.

MOUNTING DIMENSION DRAWING FOR #72N CASE						
 106 Bradrock Drive Des Plaines, Illinois U.S.A. 60018						
Dwg By	EO	App By	MW	App By	VP	
Dwg Date	01-13-15	Iss Date	01-13-15	Scale	1:8	
Sheet	1 of 1	Size	C	Dwg No	D72N	
TOP AND BOTTOM PERFORATION CHANGE	EO	MW	VP	02-27-15	02-27-15	20735
<small>Rev Description</small>	<small>By</small>	<small>Chk</small>	<small>App</small>	<small>Rev Date</small>	<small>Rev Iss Date</small>	<small>ECN No</small>

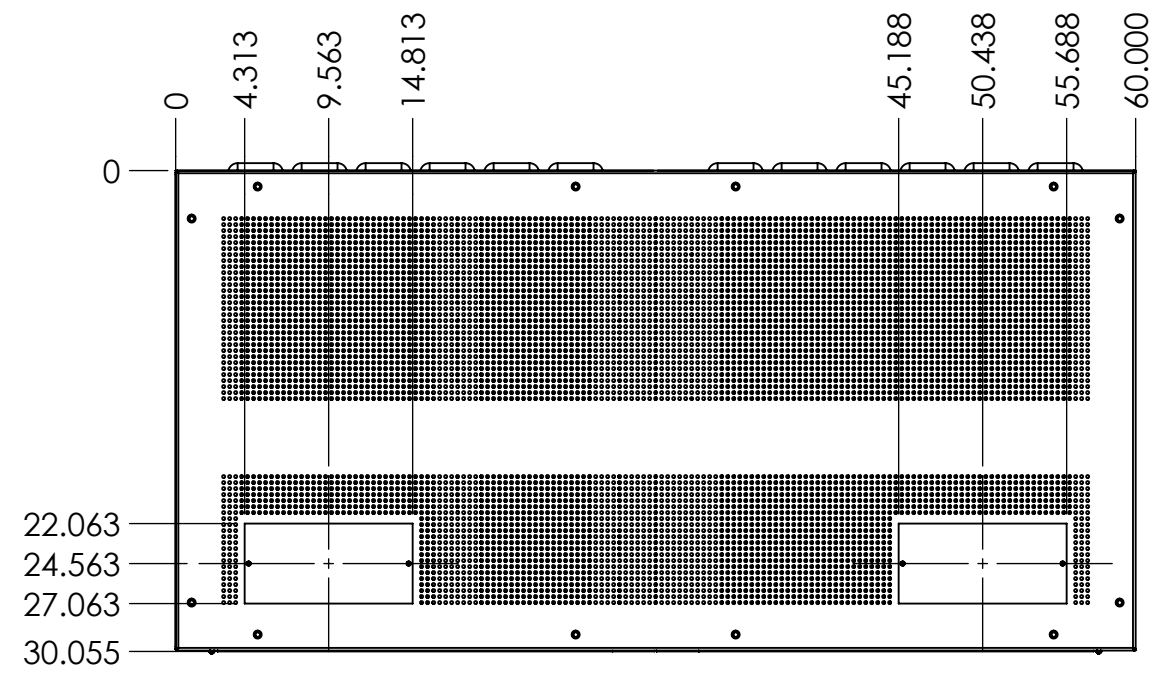

TOP VIEW

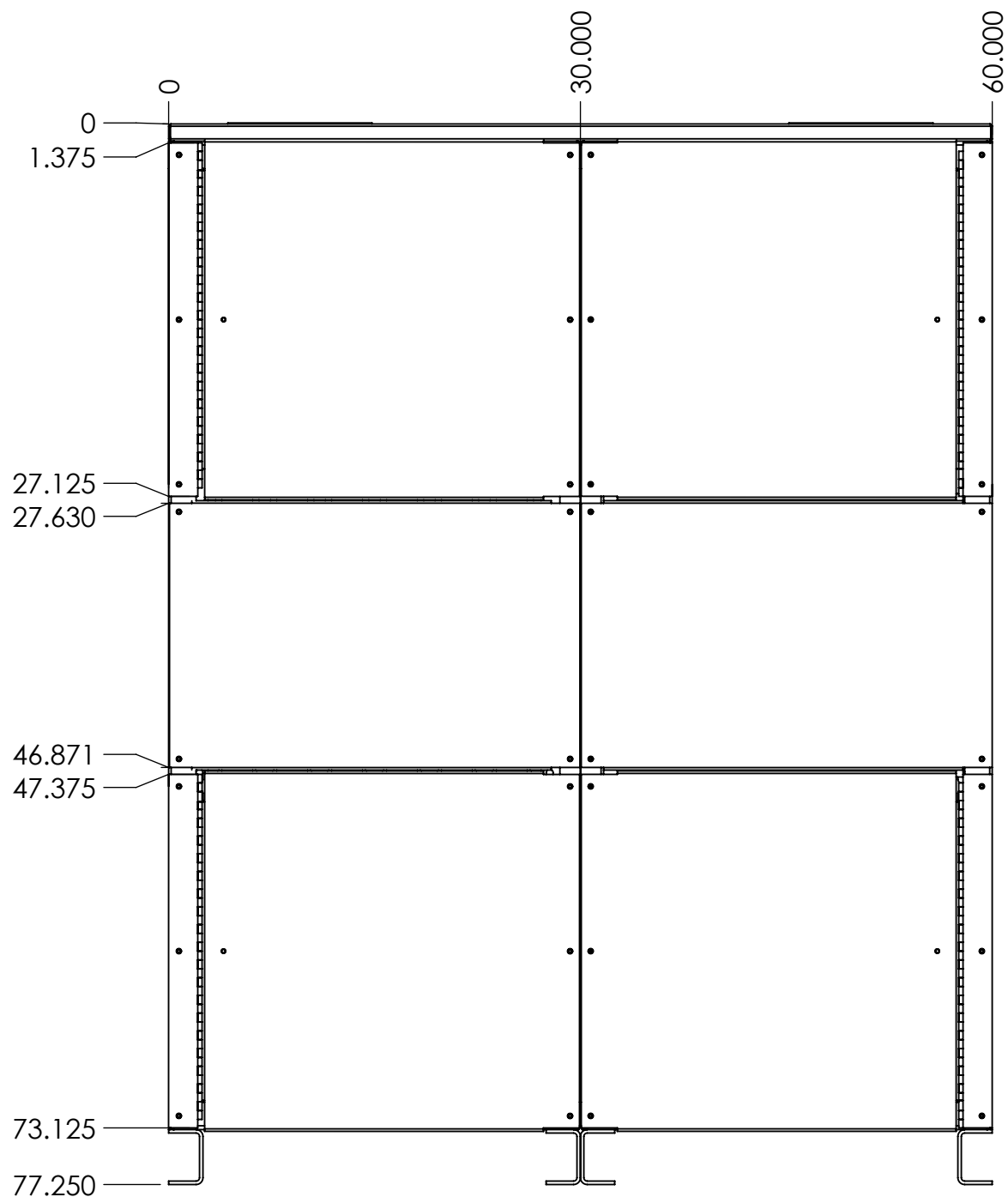

FRONT VIEW

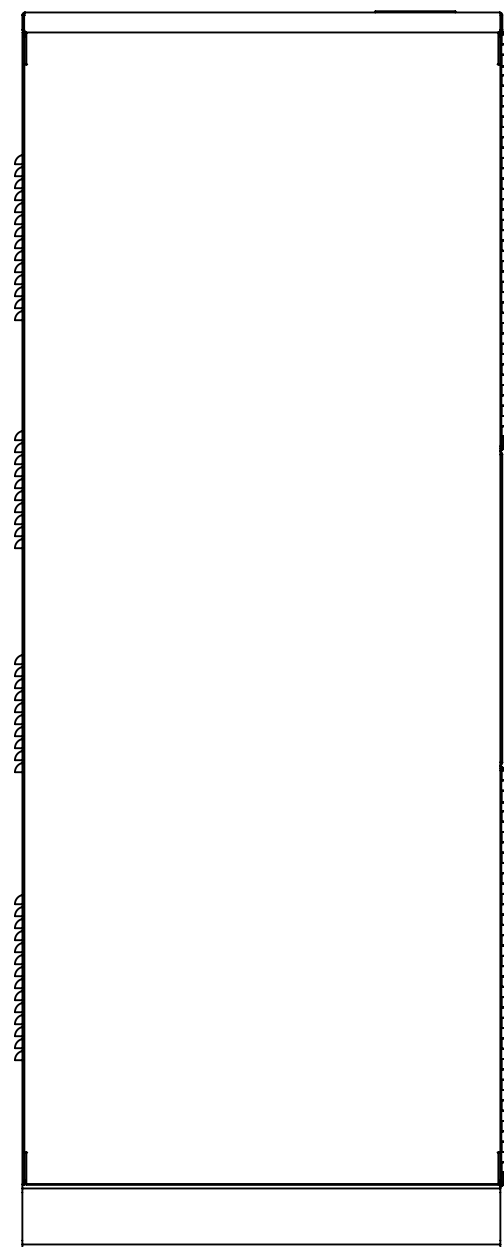

LEFT SIDE VIEW



RIGHT SIDE VIEW

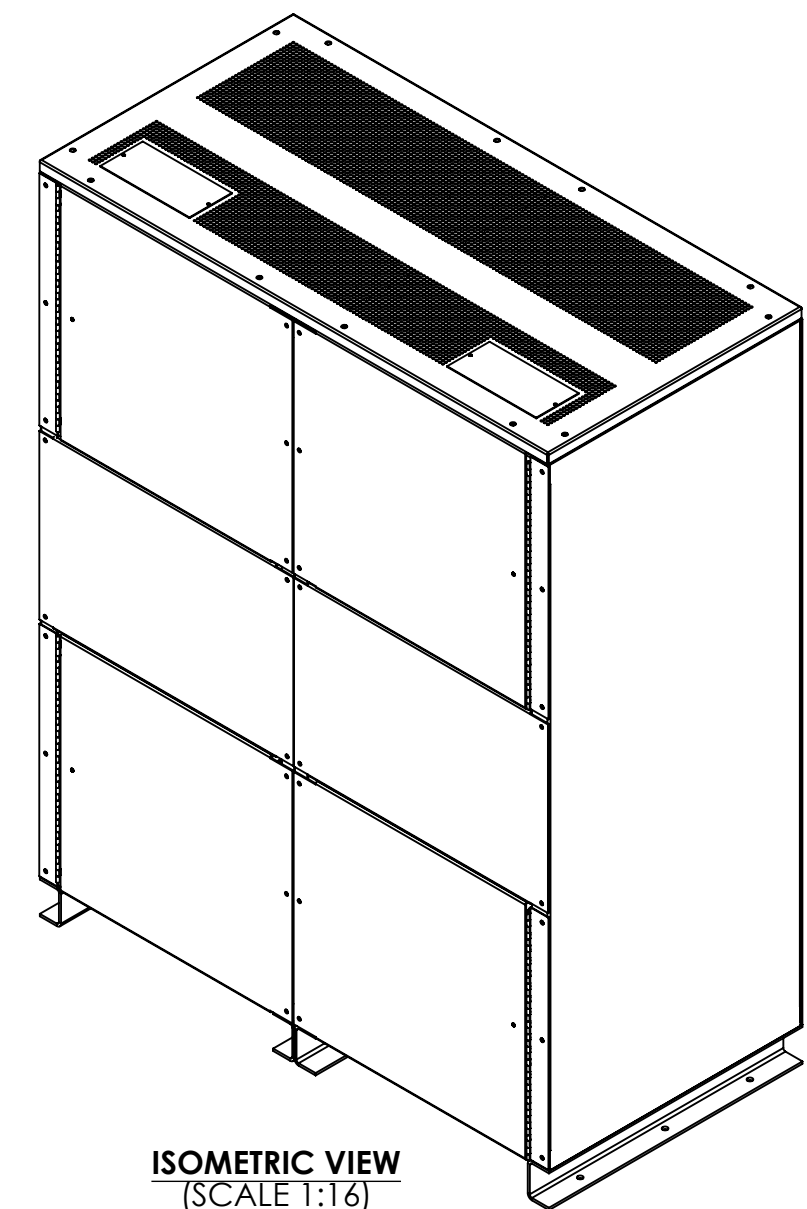

ISOMETRIC VIEW
(SCALE 1:16)

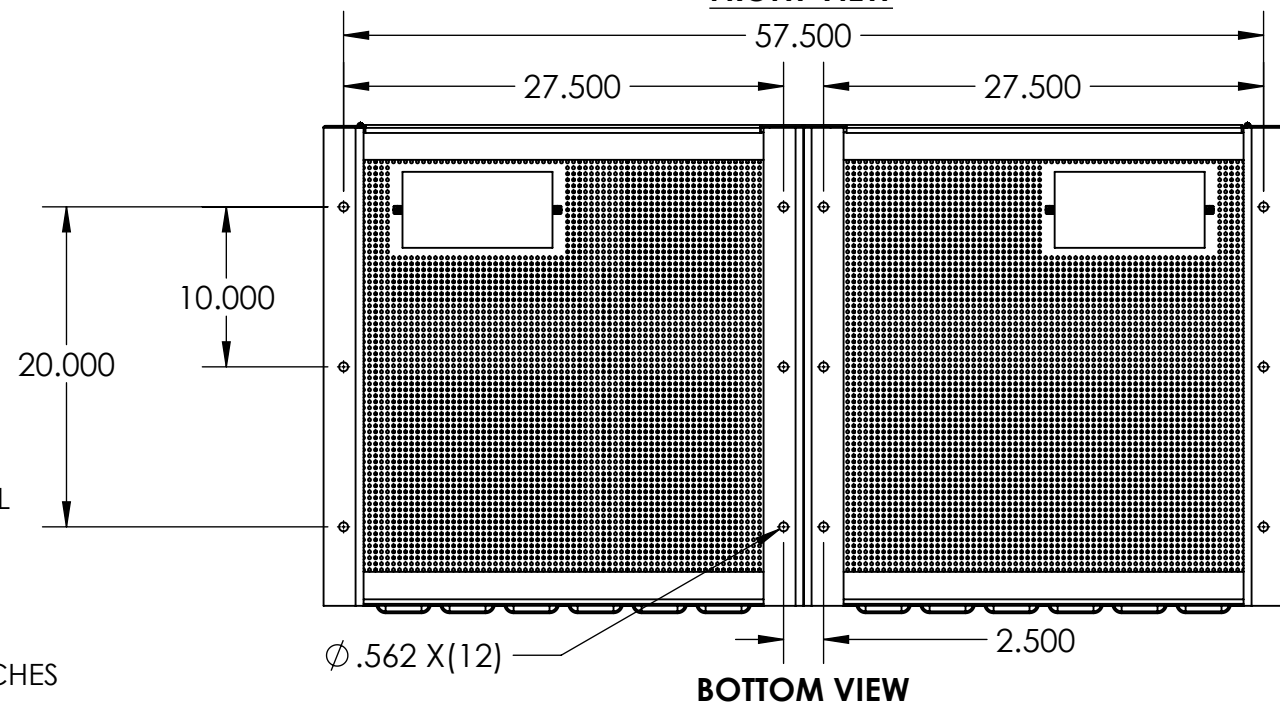

BOTTOM VIEW

- NOTES:
 1. HOUSING: 10GA SHEET STEEL
 DOOR: 14GA SHEET STEEL
 CONTROL PANEL: 16GA SHEET STEEL
 TOP: 14GA SHEET STEEL
 FLOOR BRACKET: .250" STEEL
 2. FINISH: PAINTED ANSI 61 GRAY
 3. ALL DIMENSIONS ARE GIVEN IN INCHES

MOUNTING DIMENSION DRAWING FOR
57N CASE



106 Bradrock Drive Des Plaines, Illinois U.S.A. 60018

Dwg By	PC	App By	MW	App By	VP
Dwg Date	05-19-16	Iss Date	05-19-16	Scale	NOTED

Sheet	Size	Dwg No
1 of 1	C	D57N-4

Rev Description	By	Chk	App	Rev Date	Rev Iss Date	ECN No

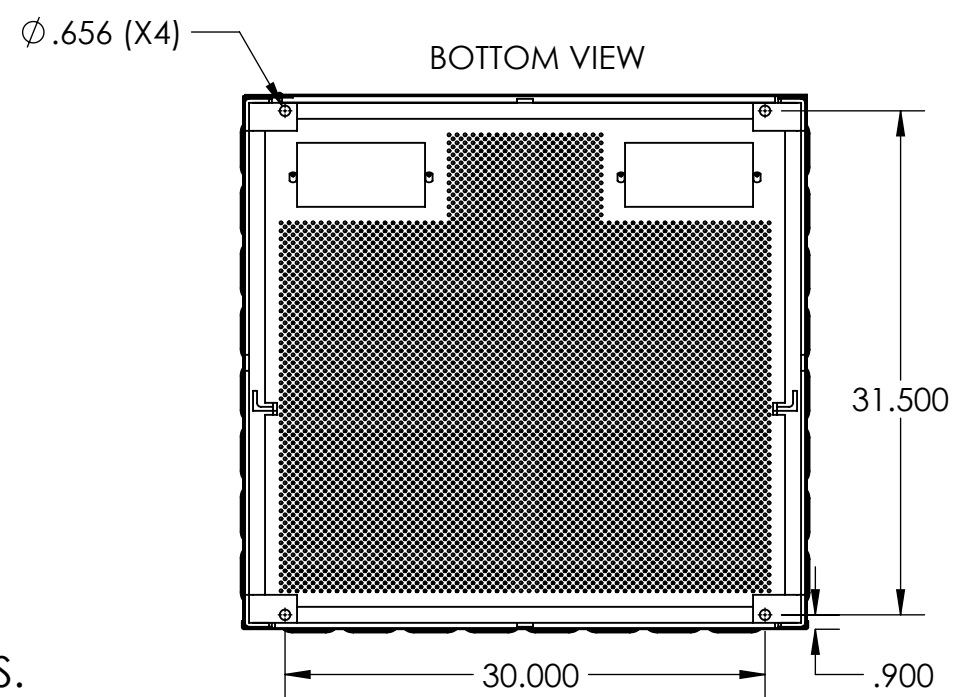
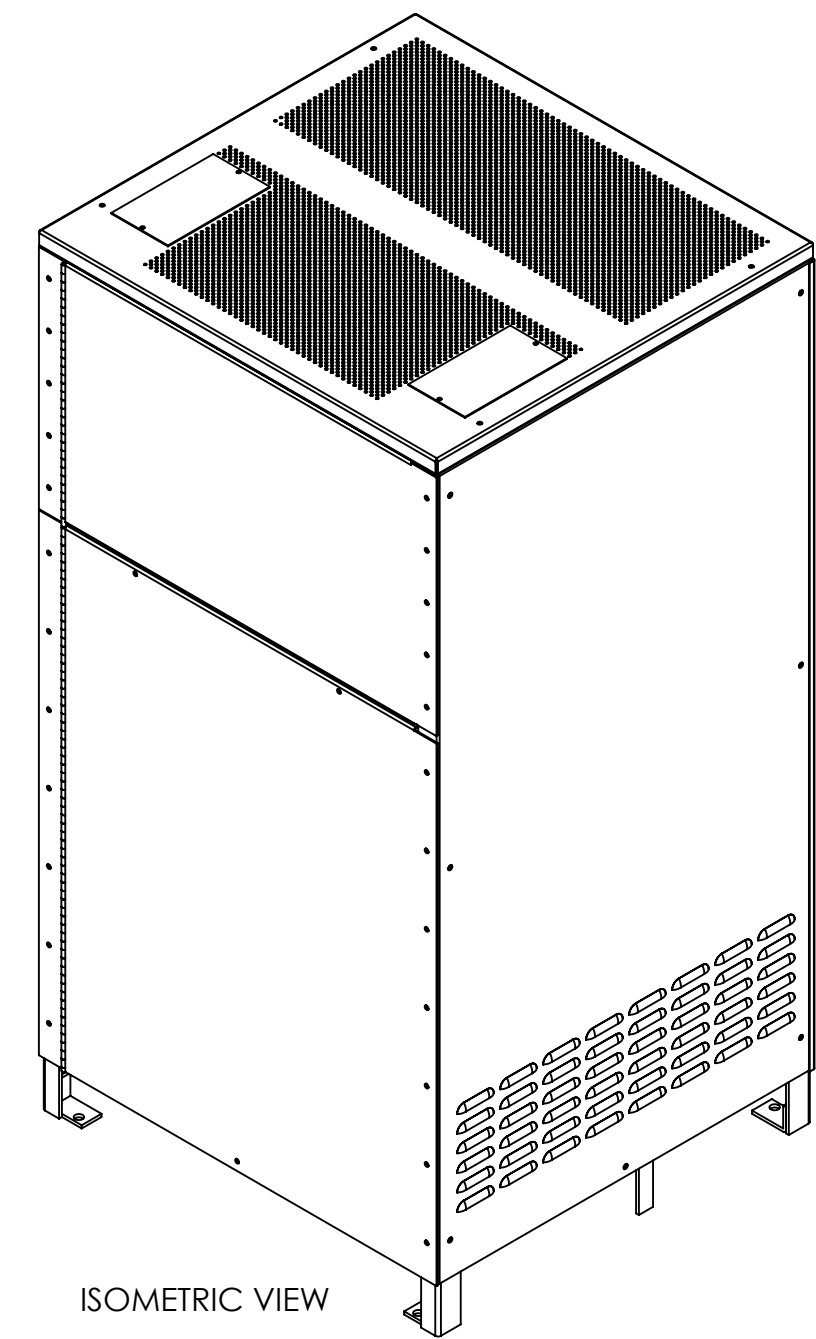
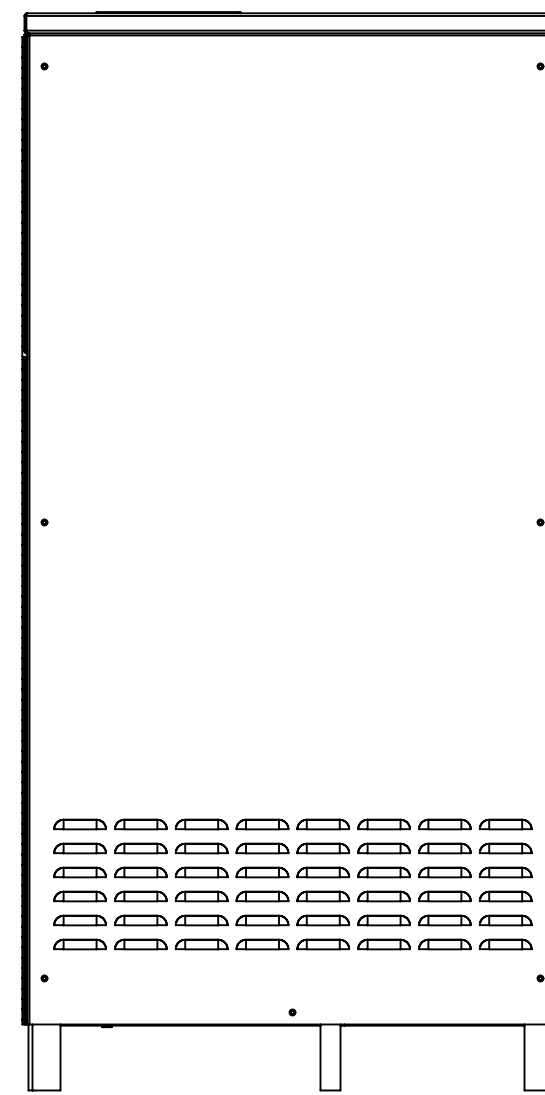
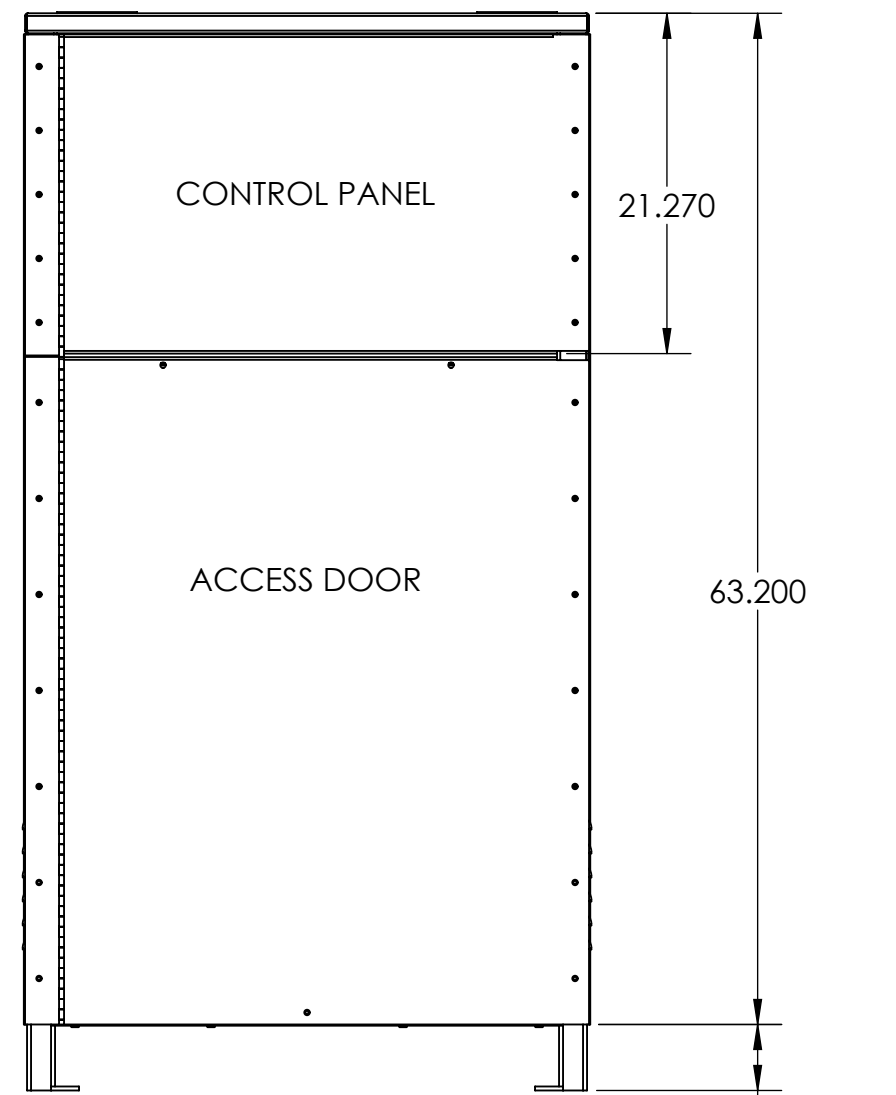
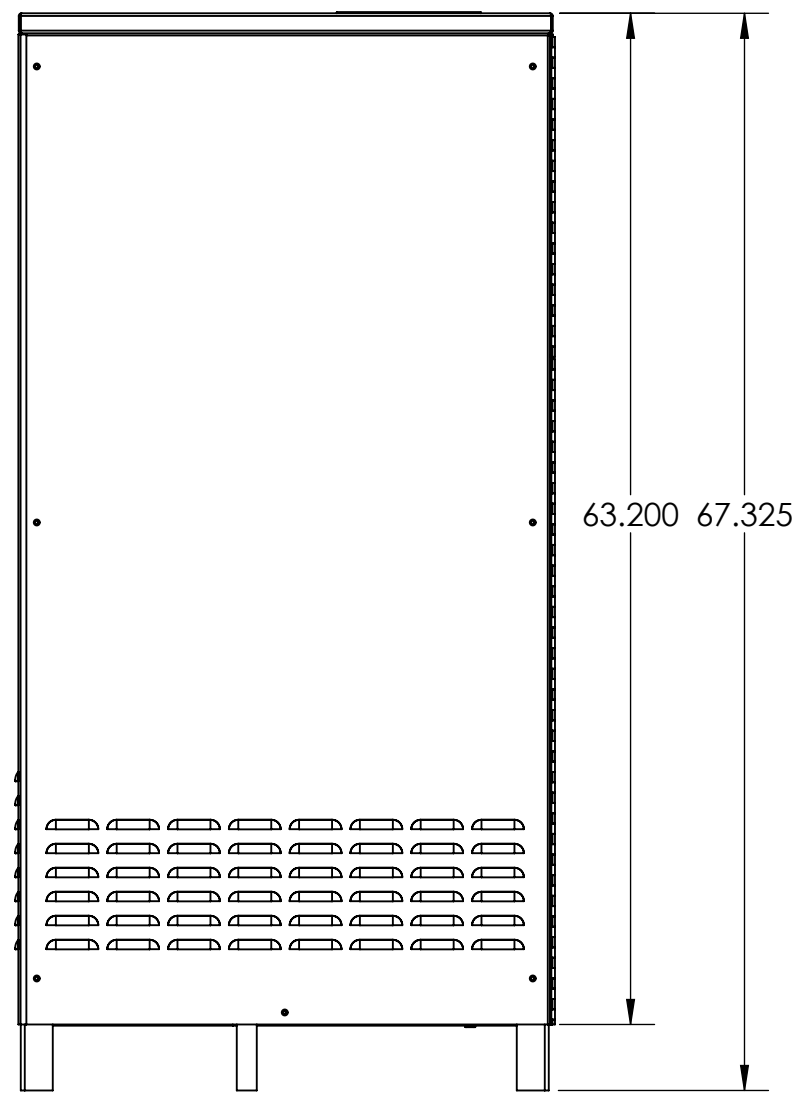
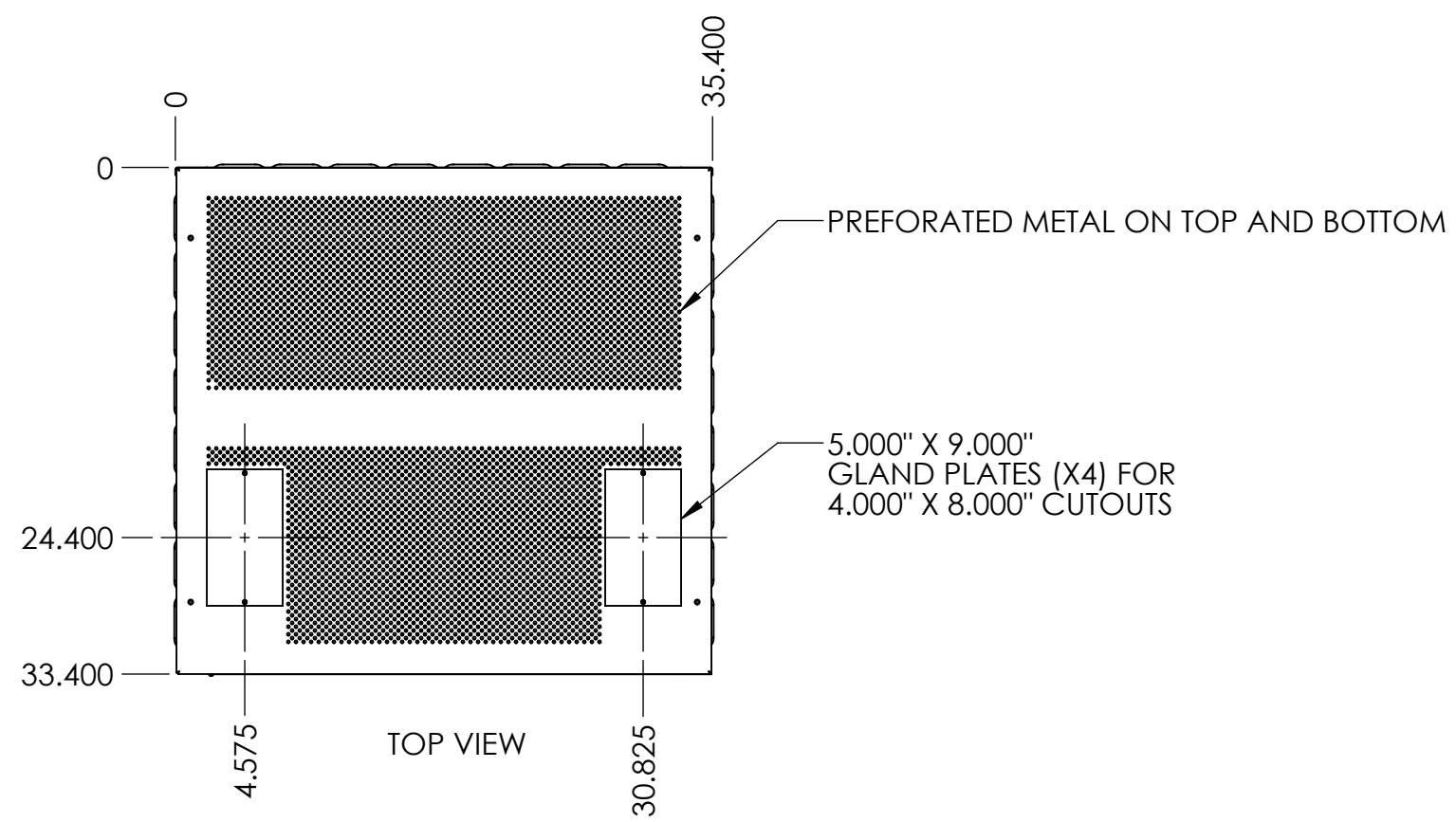

NOTES:
 1. HOUSING: 14GA SHEET STEEL
 DOOR: 12GA SHEET STEEL
 CONTROL PANEL: 16GA SHEET STEEL
 TOP: 12GA SHEET STEEL
 2. FINISH: PAINTED ANSI 61 GRAY
 3. ALL DIMENSIONS ARE GIVEN IN INCHES.

Rev	Description	By	Chk	App	Rev Date	Rev Iss Date	ECN No

MOUNTING DIMENSIONS FOR #47N CASE			
 <small>106 Bradrock Drive Des Plaines, Illinois U.S.A. 60018</small>			
Dwg By	PC	App By	MW
Dwg Date	02-11-15	Iss Date	04-02-15
App By	VP	Scale	1:12
Sheet	1 of 1	Size	C
Dwg No	D47N		

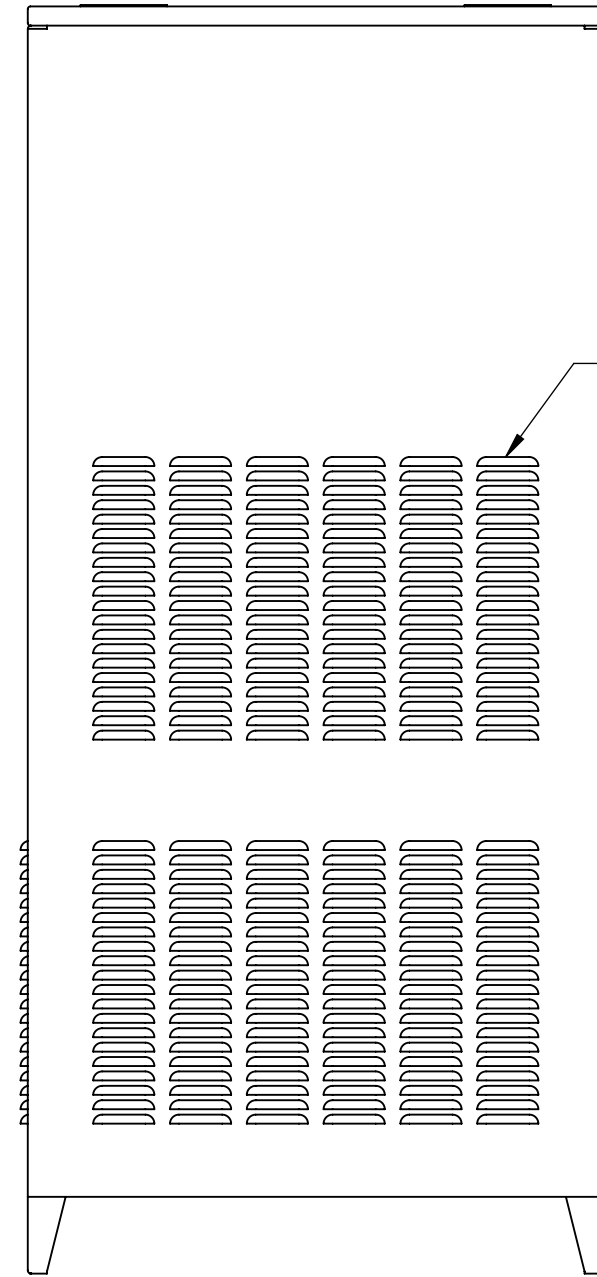
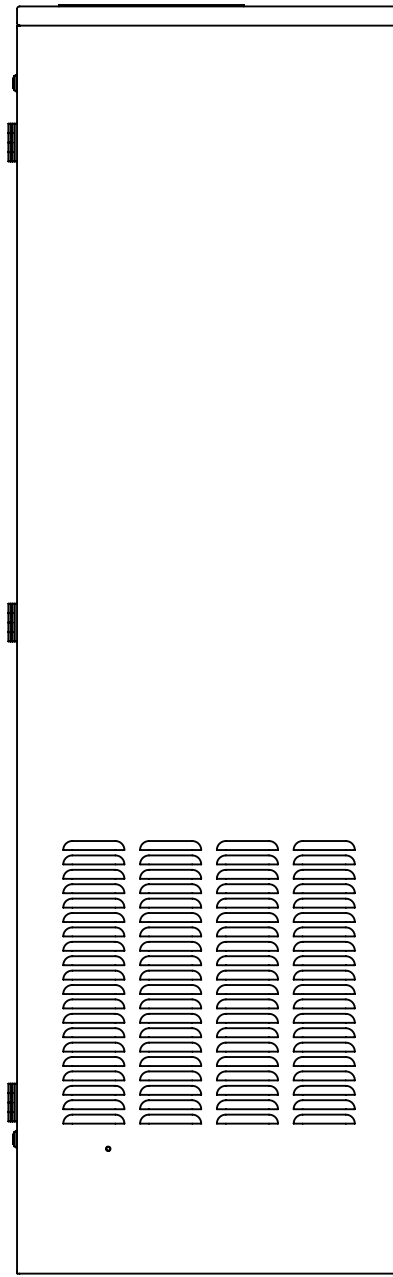
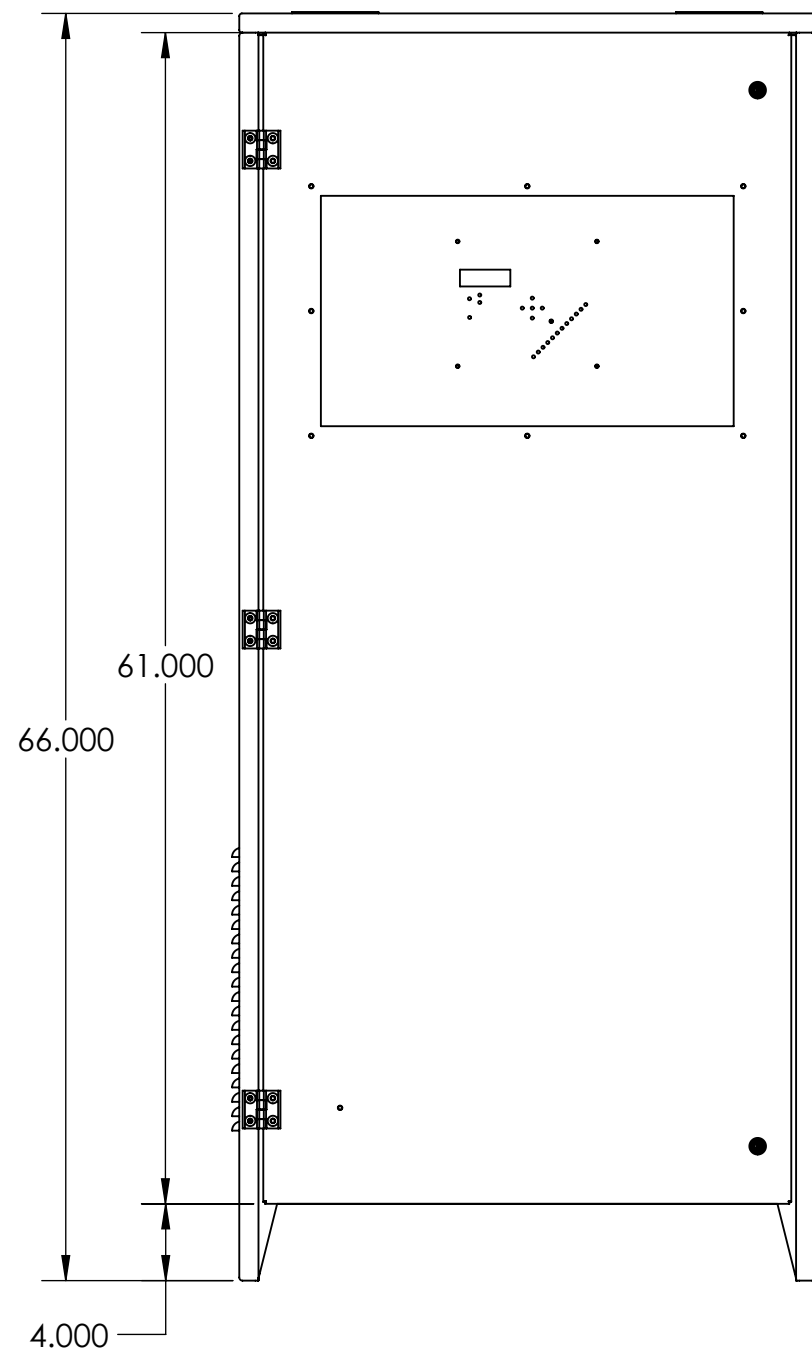
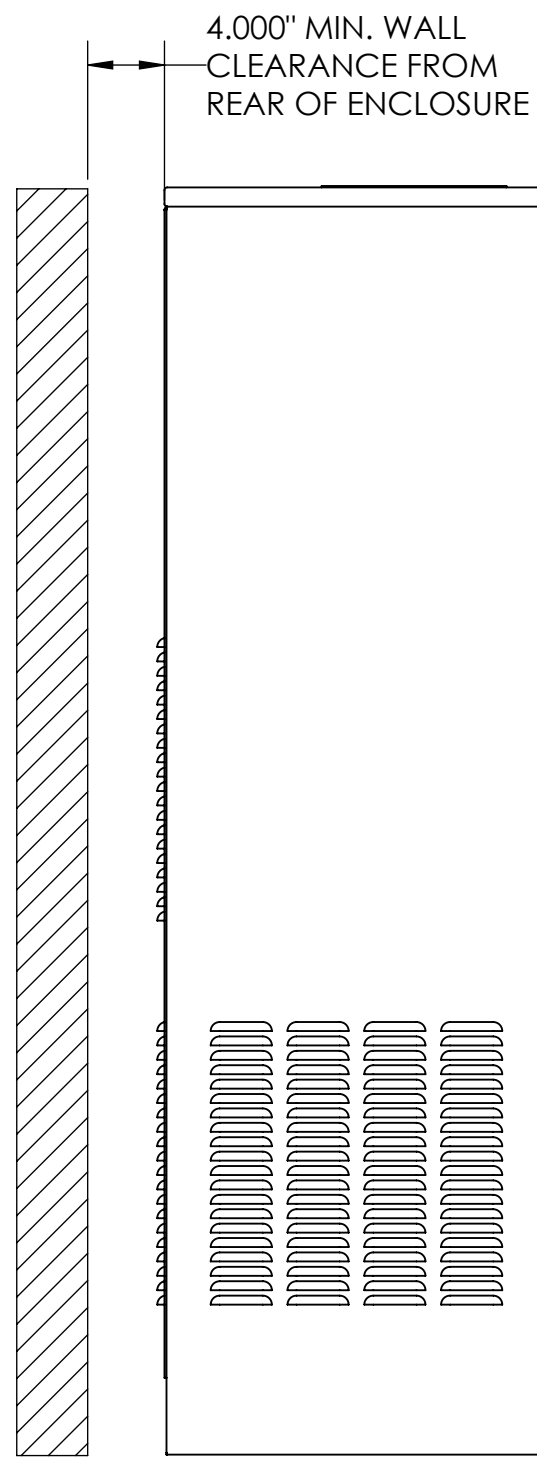
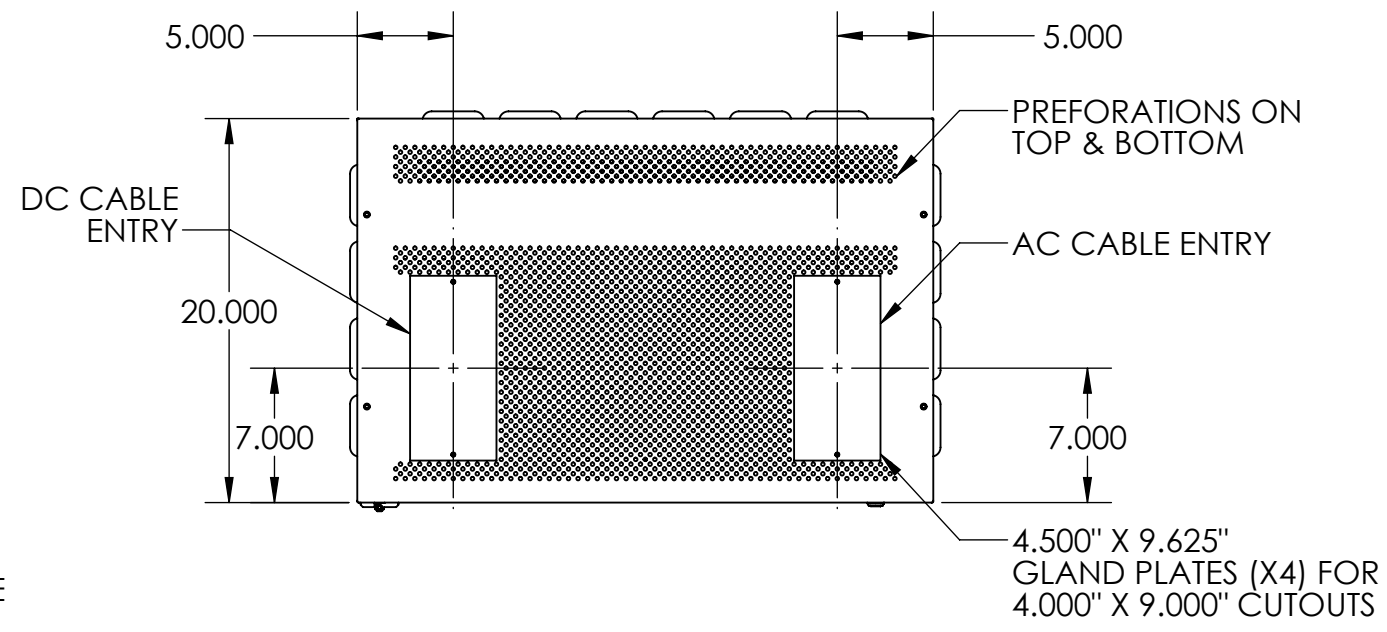

LOUVERS

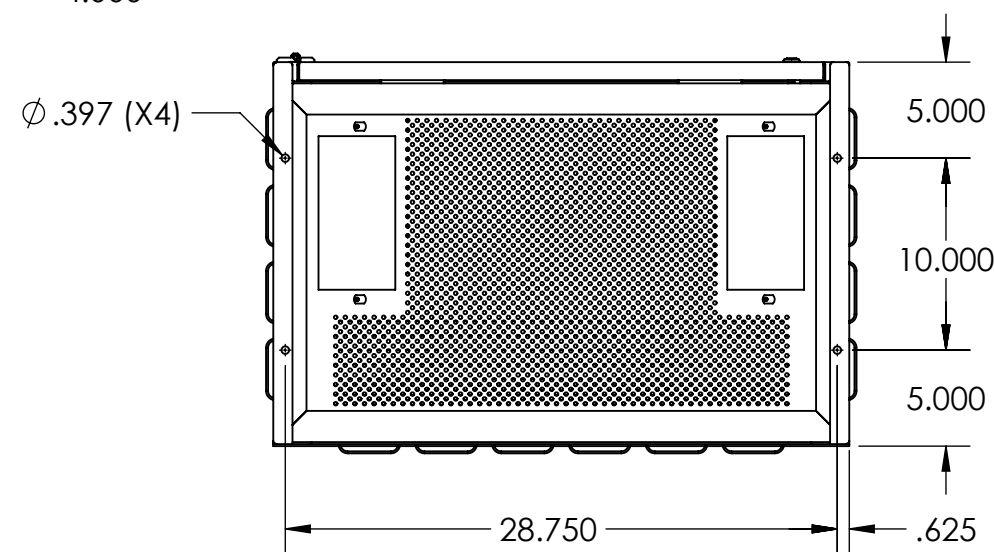
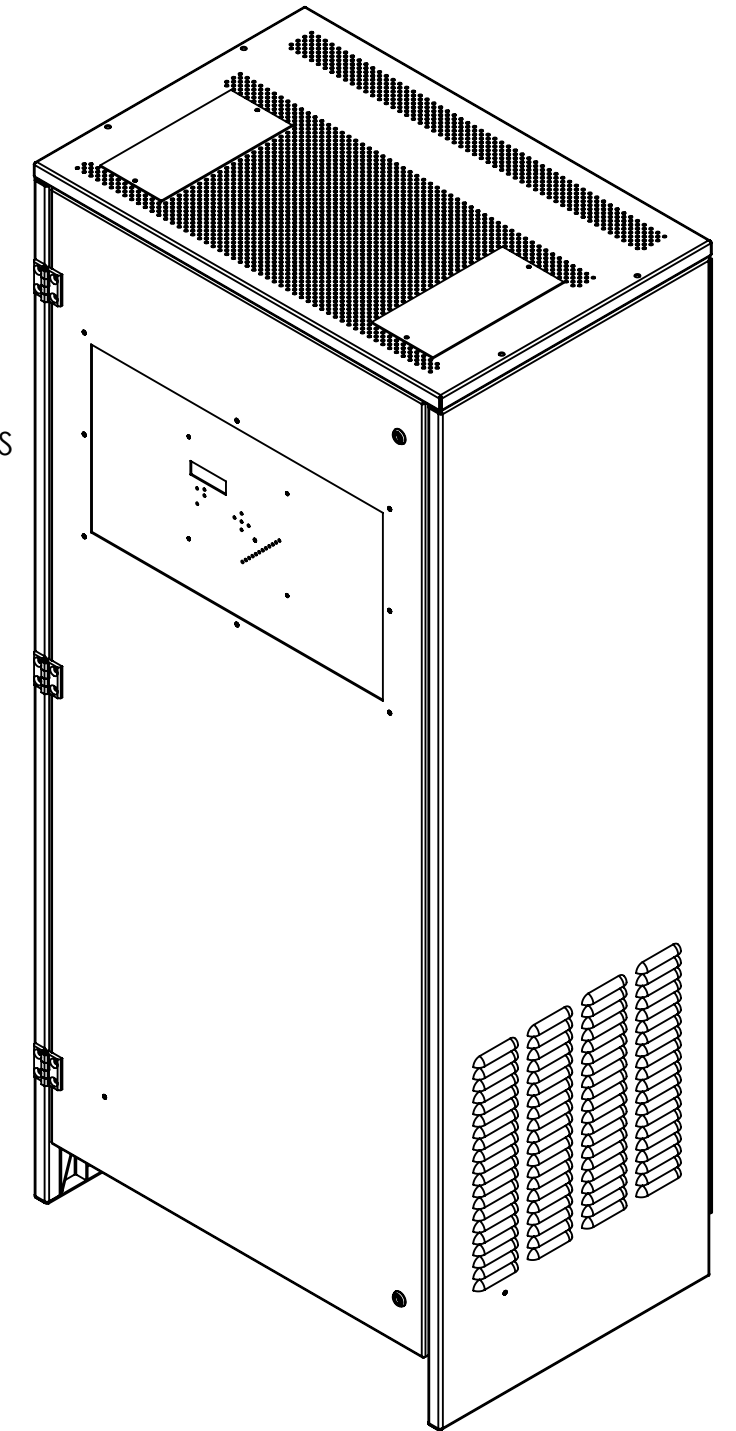

NOTES:

1. MATERIAL:
HOUSING: 14 GA. SHEET STEEL
DOORS: 14 GA. SHEET STEEL
2. FINISH: POWDER COAT ANSI GRAY

MOUNTING DIMENSION DRAWING FOR #46N CASE



106 Bradrock Drive Des Plaines, Illinois U.S.A. 60018

Dwg By	PC	App By	MW	App By	VP
Dwg Date	11-17-14	Iss Date	05-06-15	Scale	1:10

Sheet	1 of 1	Size	C	Dwg No	D46N-1
-------	--------	------	---	--------	--------

R1) REVISED DWG. TO SHOW ADD'L. LOUVERS

By	PC	Chk	MW	App	VP	Rev Date	08-04-16	Rev Iss Date	08-04-16	ECN No	21226
----	----	-----	----	-----	----	----------	----------	--------------	----------	--------	-------