

#3 CASE

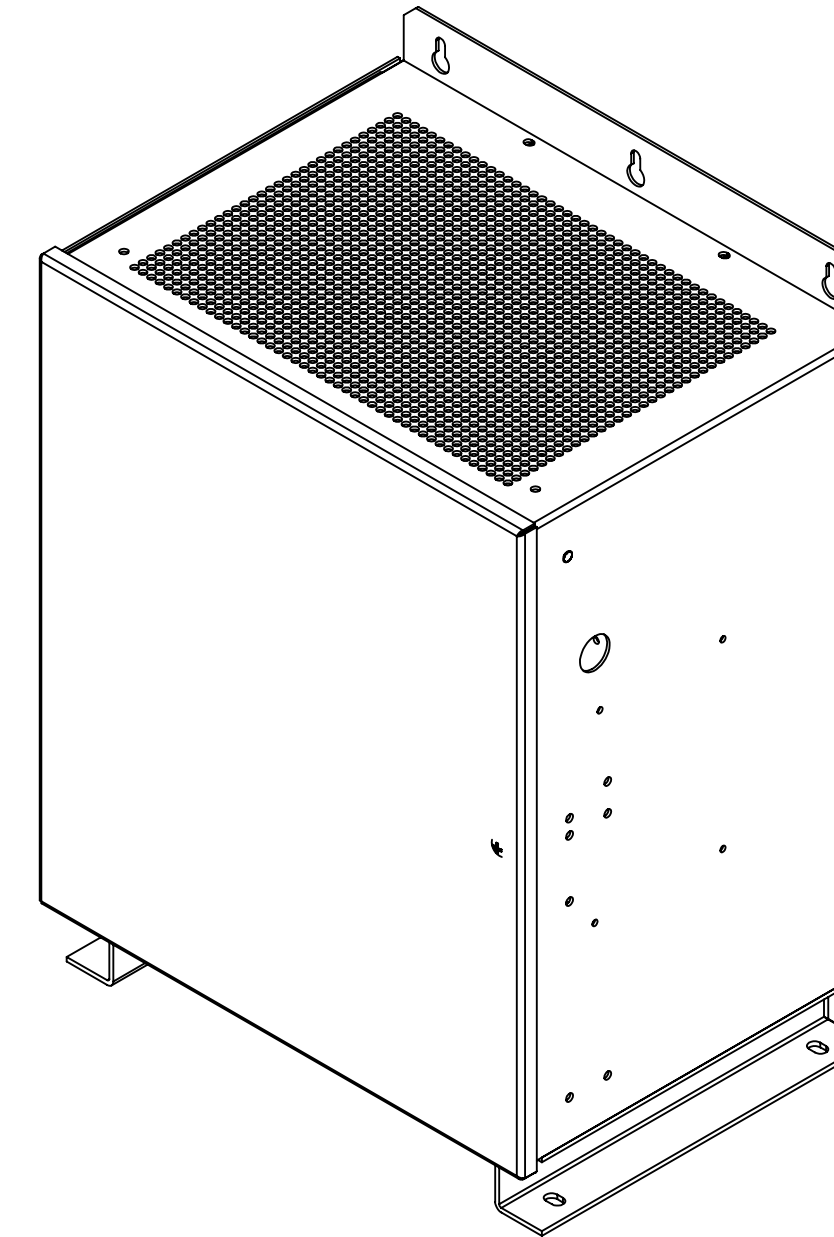

#7 CASE

							UNLESS OTHERWISE SPECIFIED: <small>(PER ENGR 3/15/12 A2-5)</small> DIMENSIONS ARE IN INCHES TOLERANCES: .XX ± .05 .XXX ± .015 ANGLE: ± 0.5° RADIUS: ± 0.015		 <small>FINISH</small>		 LaMARCHE 106 Bradrock Drive Des Plaines, Illinois 60018 U.S.A. Tel. 847-299-1188 http://www.lamarchemfg.com	
							REMOVE ALL BURRS AND BREAK SHARP EDGES .03 MAX		DRWN BY SBB CHKD BY TK APRVD BY TK		ISOMETRIC VIEW A46F ALL POPULAR CASES	
							DWG DATE 09-05-24 ISS DATE 09-05-24		SHEET 1 OF 1 SCALE 1:4		SIZE D DWG NO ALL_A46F_CASES	
REV	REV DESCRIPTION	BY	CHK	APP	REV DATE	REV ISS DATE	ECN NO					

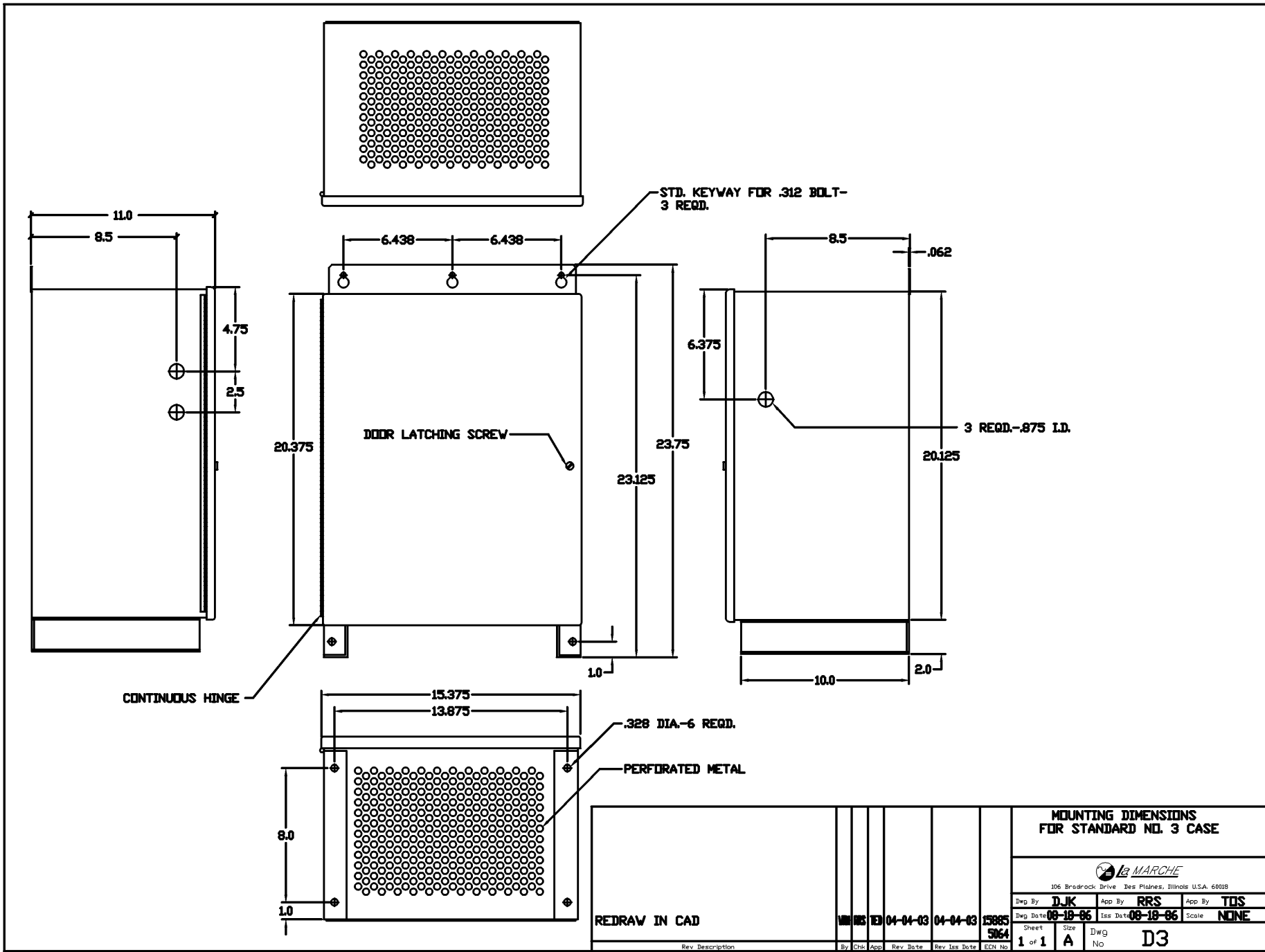

**MOUNTING DIMENSIONS
FOR STANDARD NO. 3 CASE**

 106 Broadrock Drive Des Plaines, Illinois USA 60018					
Dwg By	DJK	App By	RRS	App By	TDS
Dwg Date	08-18-86	Iss Date	08-18-86	Scale	NONE
Sheet	1 of 1	Size	A	Dwg No	D3

REDRAW IN CAD	15885	04-04-03	04-04-03	5064		
Rev Description	By	Chk	App	Rev Date	Rev Iss Date	ECN No

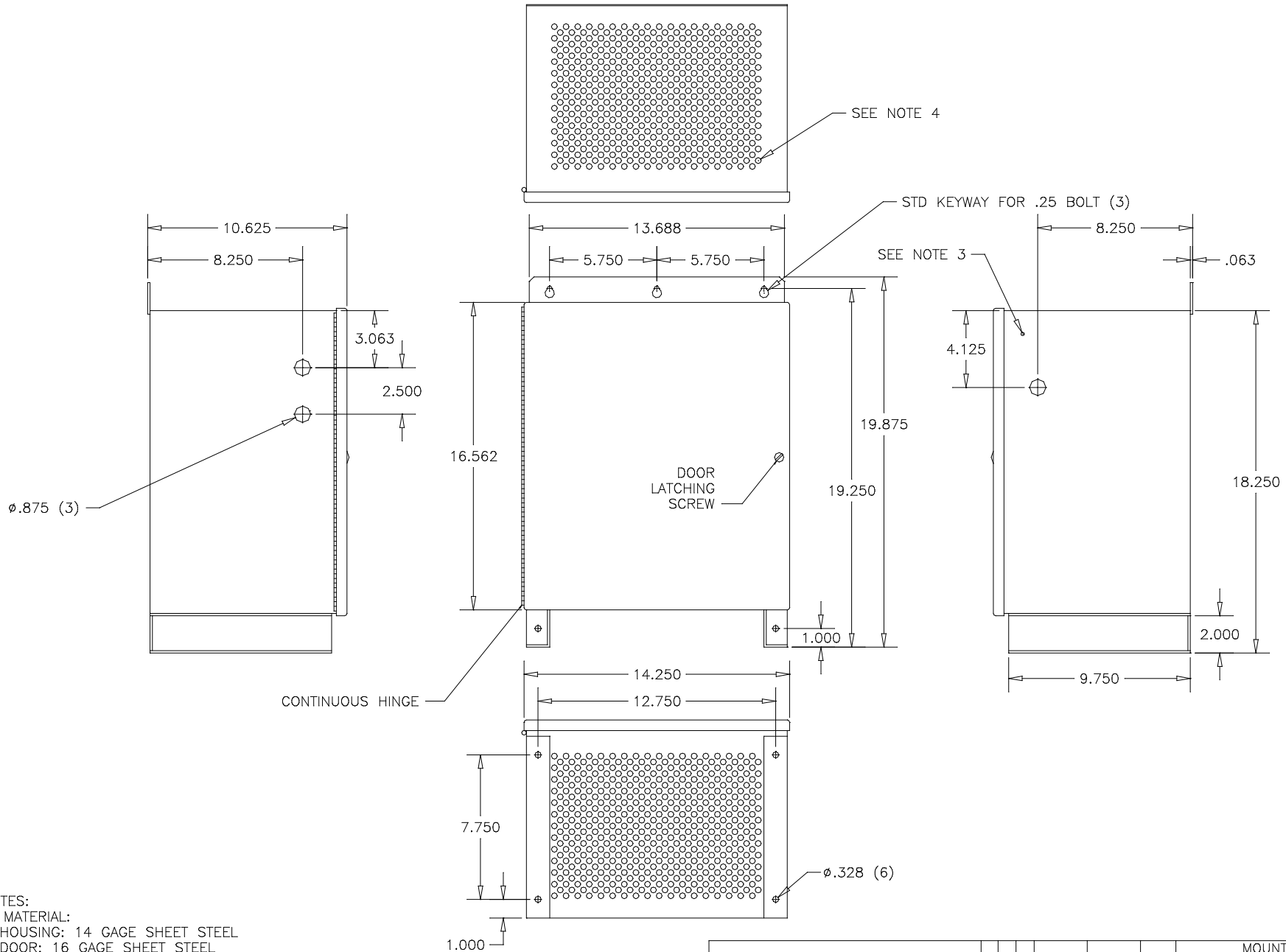

NOTES:

1. MATERIAL:
 HOUSING: 14 GAGE SHEET STEEL
 DOOR: 16 GAGE SHEET STEEL
 FLOOR MOUNTING BRACKETS: 11 GAGE SHEET STEEL
2. FINISH: ANSI #61 GREY
3. 10-32 X .625 WELDSTUD ON INSIDE OF CASE
4. PERFORATED METAL ON TOP AND BOTTOM

REDRAWN IN CAD							MOUNTING DIMENSIONS FOR #7 CASE						
							 106 Bradrock Drive Des Plaines, Illinois U.S.A. 60018						
By	JAF	App	RRS	Rev Date	4-2-02	ECN No	15307	Dwg Date	8-18-86	App By	RRS	Scale	NONE
Sheet	1	Size	C	Dwg No	D7	Rev	3044	Isa Date	8-18-86	App By	TOS	Scale	NONE
Rev	1	Description		By	Chk	App	Rev Date	Rev	Isa Date	ECN No			