

NOTES:

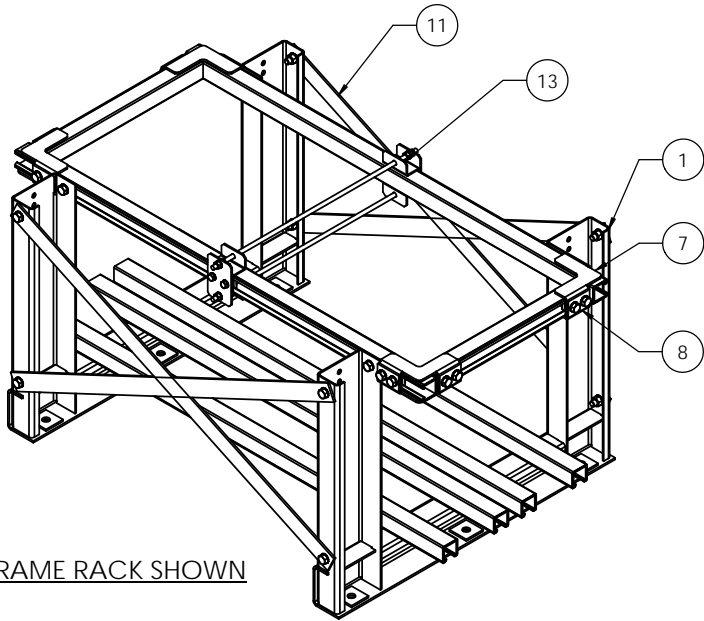

2 FRAME RACK SHOWN

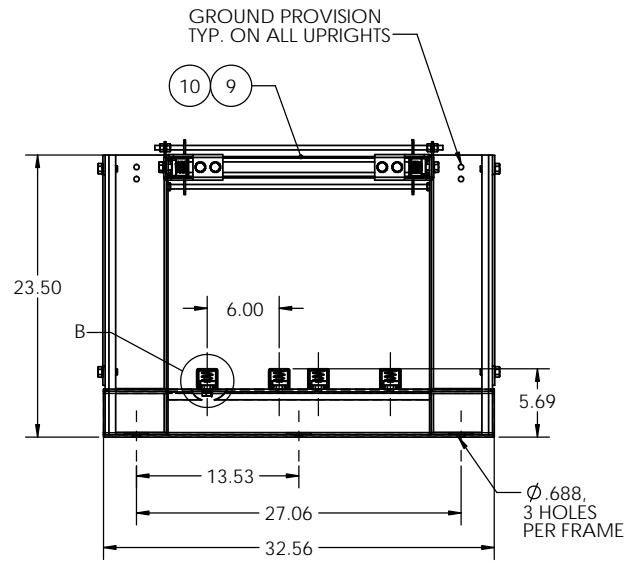

TYP END VIEW

REVISIONS			
REV.	DESCRIPTION	DATE	APPROVED
A	INITIAL RELEASE	7-27-10	RNA
B	UPDATE PER CERTIFICATION CHANGES	8/23/2011	RNA

RACK DIMENSIONS AND OTHER SPECS					
PAR NUMBER	RACK LENGTH DIM "L" (FT)	DIM "A" (IN)	DIM "B" (IN)	DIM "C" (IN)	WEIGHT
WR233-1T2R-48-Z4	4	6	36	N/A	150
WR233-1T2R-60-Z4	5	12	36	N/A	162
WR233-1T2R-72-Z4	6	12	48	N/A	177
WR233-1T2R-84-Z4	7	6	36	N/A	242
WR233-1T2R-96-Z4	8	12	36	N/A	254
WR233-1T2R-108-Z4	9	6	48	N/A	270
WR233-1T2R-120-Z4	10	12	48	N/A	282
WR233-1T2R-132-Z4	11	12	36	36	341
WR233-1T2R-144-Z4	12	12	48	36	355
WR233-1T2R-156-Z4	13	6	48	48	371
WR233-1T2R-168-Z4	14	12	48	48	383
WR233-1T2R-180-Z4	15	6	48	36	449
WR233-1T2R-192-Z4	16	12	48	36	461
WR233-1T2R-204-Z4	17	6	48	48	477
WR233-1T2R-216-Z4	18	12	48	48	489
WR233-1T2R-228-Z4	19	6	48	36	550
WR233-1T2R-240-Z4	20	12	48	36	562

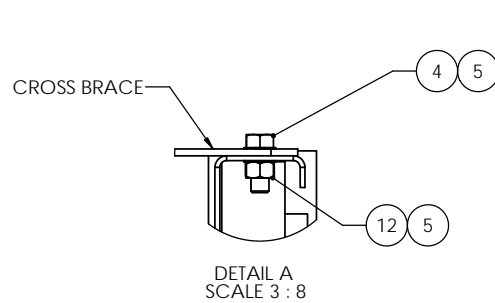

DETAIL A
SCALE 3 : 8

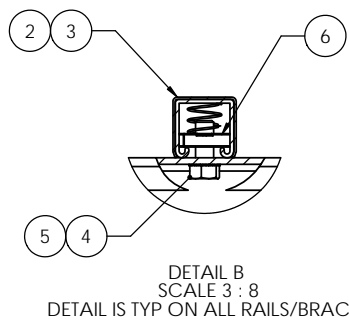

DETAIL B
SCALE 3 : 8
DETAIL IS TYP ON ALL RAILS/BRACES

BRACE TABLE			
RACK MODEL	RACK LENGTH (FT)	BRACE P/N	
		BRC-010700	BRC-010800
WR233-1T2R-48-Z4	4	4	N/A
WR233-1T2R-60-Z4	5	4	N/A
WR233-1T2R-72-Z4	6	N/A	4
WR233-1T2R-84-Z4	7	8	N/A
WR233-1T2R-96-Z4	8	8	N/A
WR233-1T2R-108-Z4	9	N/A	8
WR233-1T2R-120-Z4	10	N/A	8
WR233-1T2R-132-Z4	11	12	NA
WR233-1T2R-144-Z4	12	8	4
WR233-1T2R-156-Z4	13	N/A	12
WR233-1T2R-168-Z4	14	N/A	12
WR233-1T2R-180-Z4	15	8	8
WR233-1T2R-192-Z4	16	8	8
WR233-1T2R-204-Z4	17	N/A	16
WR233-1T2R-216-Z4	18	N/A	16
WR233-1T2R-228-Z4	19	8	12
WR233-1T2R-240-Z4	20	8	12

PARTS LIST																			
ITEM NO.	PART NUMBER	DESCRIPTION	4'	5'	6'	7'	8'	9'	10'	11'	12'	13'	14'	15'	16'	17'	18'	19'	20'
1	FRM-026400	FRAME, 1 TIER/2 ROW, OPZs 900-1000, Z4	2	2	2	3	3	3	3	4	4	4	4	5	5	5	5	6	6
2	BTR-000300	RAIL, BATTERY, 1.625 X 1.625 X "L"	6	6	6	6	6	6	6	6	6	6	6	6	6	6	6	6	6
3	MIS-001900	PLASTIC COVER, BATT. RAIL, "L"	6	6	6	6	6	6	6	6	6	6	6	6	6	6	6	6	6
4	HEXBOLT1/2-13X1-1/4ZC	HEX BOLT, 1/2-13 X 1-1/4", ZC	36	36	36	44	44	44	44	52	52	52	52	60	60	60	60	68	68
5	EXTTOOTHWASHER1/2ZC	WASHER, LOCK, EXTERNAL TOOTH, 1/2", ZC	44	44	44	58	58	58	58	72	72	72	72	86	86	86	86	100	100
6	P1010	NUT, UNISIRUT, 1/2-13	28	28	28	34	34	34	34	40	40	40	40	46	46	46	46	52	52
7	BKT-000902	BRACKET, CORNER, SHORT, 1/2" HDWR	4	4	4	4	4	4	4	4	4	4	4	4	4	4	4	4	4
8	BKT-002102	BRACKET, CORNER, BOTTOM, 1/2" HDWR	4	4	4	4	4	4	4	4	4	4	4	4	4	4	4	4	4
9	MIS-002600	PLASTIC COVER, BATT. RAIL, 18.375"	2	2	2	2	2	2	2	2	2	2	2	2	2	2	2	2	2
10	BRC-003400	BRACE, END, SEISMIC, 18.375"	2	2	2	2	2	2	2	2	2	2	2	2	2	2	2	2	2
11	SEE BRACE TABLE	BRACE, CROSS	SEE CROSS BRACE CHART																
12	HEXNUT1/2-13HEXZC	HEX NUT, 1/2-13, ZINC	8	8	8	12	12	12	12	16	16	16	16	20	20	20	20	24	24
13	KIT-003624	INTER. SUPPORT, WCR, 3/8 HDWR, 24"	0	0	0	1	1	1	1	1	1	1	1	2	2	2	2	2	2

- NOTES:
- EPOXY POWDER COATED FRAMES
 - STANDARD RAILS AND SEISMIC BRACES ARE GALVANIZED.
 - REFER TO PAGE 2 FOR FRAME TO FRAME DIMENSIONS DEPENDING ON THE LENGTH OF RACK.
 - BRACES USED ARE DEPENDENT ON DIMENSIONS BETWEEN FRAMES. REFERENCE PAGE 2 AND BRACE TABLES TO DETERMINE LOCATION OF BRACES DEPENDING ON THE BRACE'S LENGTHS.

UNLESS OTHERWISE SPECIFIED			
DIMENSIONS ARE IN INCHES			
TOLERANCES:			
ANGULAR: MACH ± .5 BEND ± 1			
TWO PLACE DECIMAL ± .01			
THREE PLACE DECIMAL ± .005			
DRAWN	NAME	DATE	TITLE: STT SERIES 900-1000
CHECKED			1 TIER/2 ROWS ZONE 4 RACKS
ENG APPR			SIZE: C
MFG APPR			DWG. NO. WR233-1T2R Z4
DO NOT SCALE DRAWING			REV: B
			SCALE: 1:8 WEIGHT: SHEET 1 OF 2

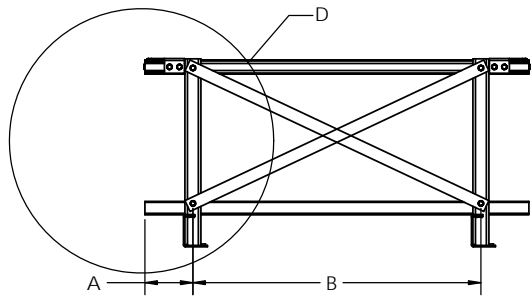

4' - 6' RACKS (2 FRAMES)

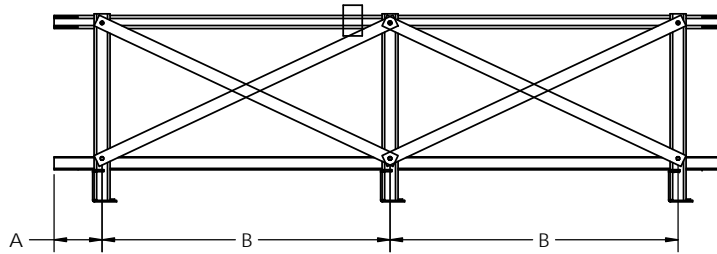

7' - 10' RACKS (3 FRAMES)

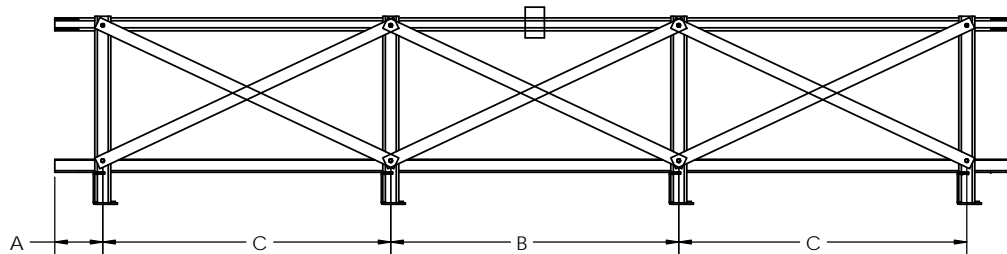

11' - 14' RACKS (4 FRAMES)

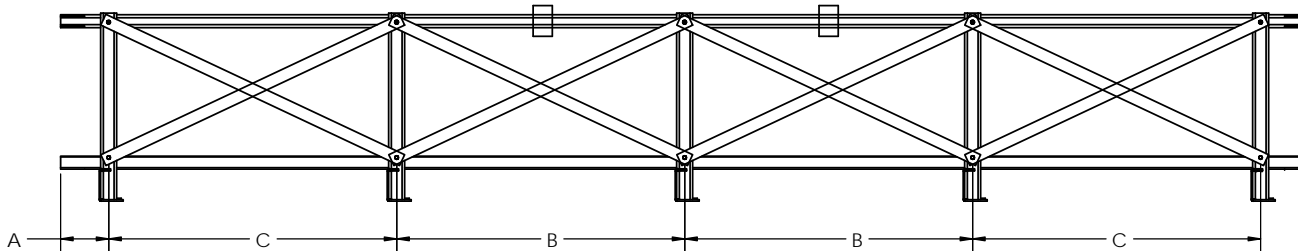

15' - 18' RACKS (5 FRAMES)

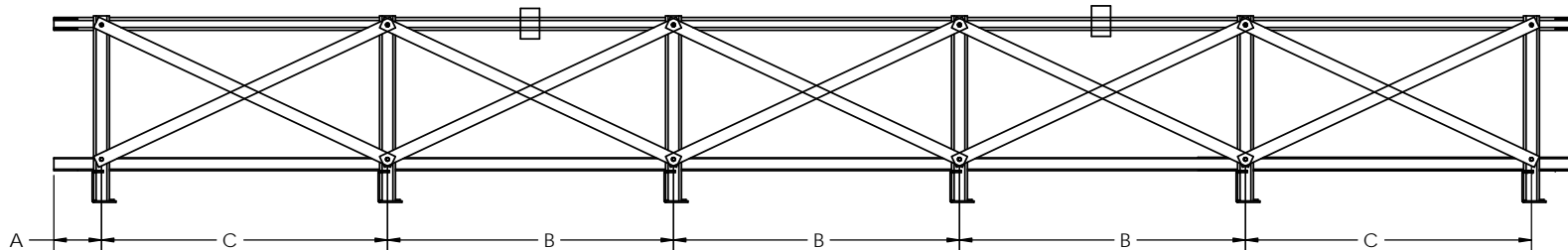

19' - 20' RACKS (6 FRAMES)

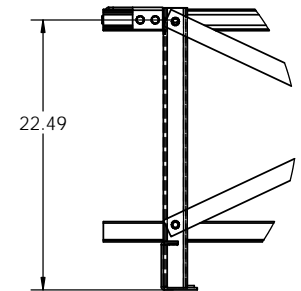

DETAIL D
DETAILS SHOWS HEIGHT PLACEMENT
OF SEISMIC BRACING. THE HEIGHT
IS DEPENDENT ON THE MODEL OF
OPzS BATTERY