

NOTES:

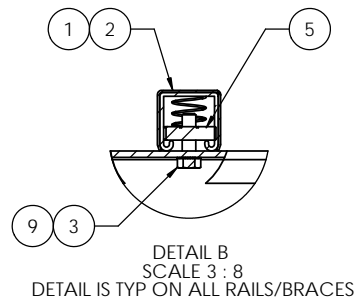
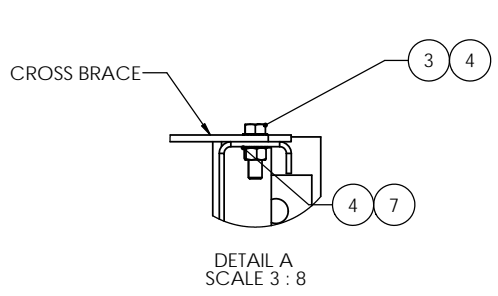
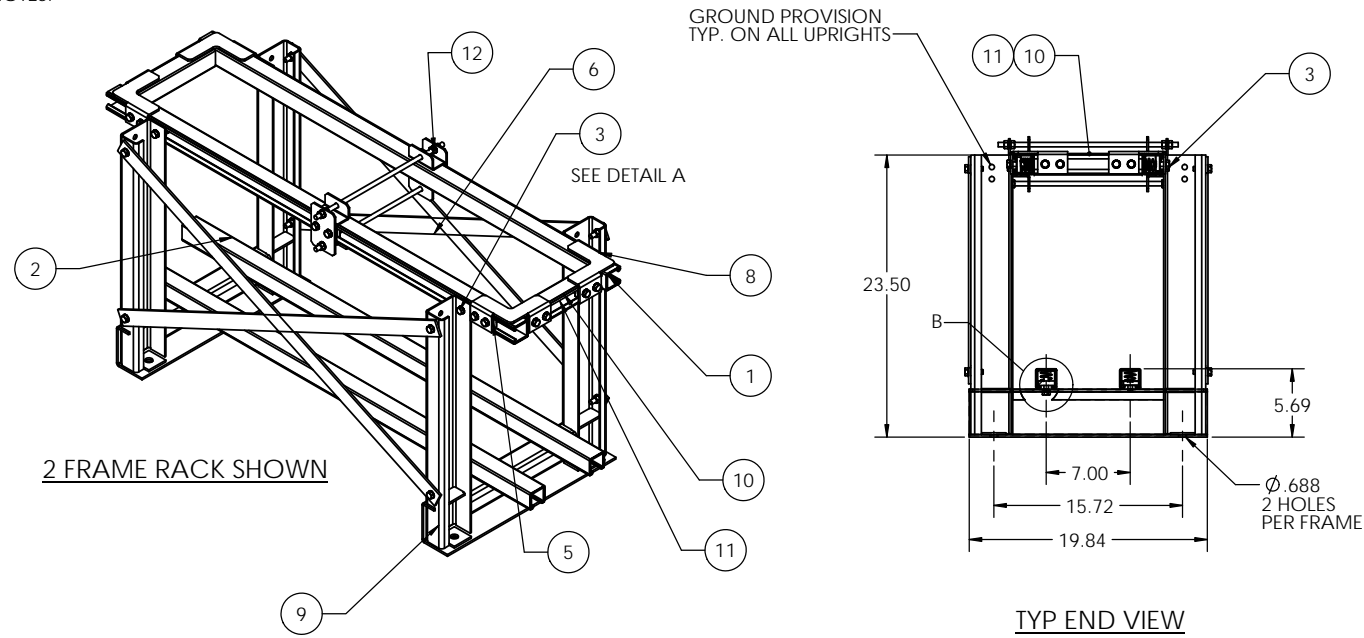

REVISIONS			
REV.	DESCRIPTION	DATE	APPROVED
A	INITIAL RELEASE	7-22-10	RNA
B	UPDATE PER CERTIFICATION CHANGES	8-18-11	RNA

RACK DIMENSIONS AND OTHER SPECS					
PAR NUMBER	RACK LENGTH DIM "L" (FT)	DIM "A" (IN)	DIM "B" (IN)	DIM "C" (IN)	WEIGHT
WR233-1T1R-48-Z4	4	6	36	N/A	105
WR233-1T1R-60-Z4	5	12	36	N/A	113
WR233-1T1R-72-Z4	6	12	48	N/A	123
WR233-1T1R-84-Z4	7	6	36	N/A	167
WR233-1T1R-96-Z4	8	12	36	N/A	175
WR233-1T1R-108-Z4	9	6	48	N/A	187
WR233-1T1R-120-Z4	10	12	48	N/A	195
WR233-1T1R-132-Z4	11	12	36	36	241
WR233-1T1R-144-Z4	12	12	48	36	251
WR233-1T1R-156-Z4	13	6	48	48	263
WR233-1T1R-168-Z4	14	12	48	48	271
WR233-1T1R-180-Z4	15	6	48	36	314
WR233-1T1R-192-Z4	16	12	48	36	322
WR233-1T1R-204-Z4	17	6	48	48	334
WR233-1T1R-216-Z4	18	12	48	48	342
WR233-1T1R-228-Z4	19	6	48	36	390
WR233-1T1R-240-Z4	20	12	48	36	398

BRACE TABLE			
RACK MODEL	RACK LENGTH (FT)	BRACE P/N	
		BRC-001800	BRC-003600
WR233-1T1R-48-Z4	4	4	N/A
WR233-1T1R-60-Z4	5	4	N/A
WR233-1T1R-72-Z4	6	N/A	4
WR233-1T1R-84-Z4	7	8	N/A
WR233-1T1R-96-Z4	8	8	N/A
WR233-1T1R-108-Z4	9	N/A	8
WR233-1T1R-120-Z4	10	N/A	8
WR233-1T1R-132-Z4	11	12	NA
WR233-1T1R-144-Z4	12	8	4
WR233-1T1R-156-Z4	13	N/A	12
WR233-1T1R-168-Z4	14	N/A	12
WR233-1T1R-180-Z4	15	8	8
WR233-1T1R-192-Z4	16	8	8
WR233-1T1R-204-Z4	17	N/A	16
WR233-1T1R-216-Z4	18	N/A	16
WR233-1T1R-228-Z4	19	8	12
WR233-1T1R-240-Z4	20	8	12

PARTS LIST																					
ITEM NO.	PART NUMBER	DESCRIPTION	4'	5'	6'	7'	8'	9'	10'	11'	12'	13'	14'	15'	16'	17'	18'	19'	20'		
1	FRM-022900	FRAME, 1 TIER, ZONE 4, SIT2V 900-1000	2	2	2	3	3	3	3	4	4	4	4	5	5	5	5	6	6		
2	BTR-000300	RAIL, BATTERY, 1.625 X 1.625 X "L"	4	4	4	4	4	4	4	4	4	4	4	4	4	4	4	4	4		
3	MIS-000300	PLASTIC COVER, BATT. RAIL, "L"	4	4	4	4	4	4	4	4	4	4	4	4	4	4	4	4	4		
4	HEXBOLT3/8-16X1-1/4ZINC	HBOLT 0.3750-16x1-1/4", Z.P.	32	32	32	40	40	40	40	48	48	48	48	56	56	56	56	64	64		
5	EXTTOOTHWASHER3/8ZC	3/8" EXTERNAL TOOTH LOCK WASHER, Z.P.	40	40	40	52	52	52	52	64	64	64	64	76	76	76	76	88	88		
6	P1008	NUT,UNISTRUT, 3/8-16	24	24	24	28	28	28	28	32	32	32	32	36	36	36	36	40	40		
7	BKT-000901	BRACKET, SHORT, WET CELL RACKS, .375 HOLES	4	4	4	4	4	4	4	4	4	4	4	4	4	4	4	4	4		
8	MIS-002000	PLASTIC COVER, BATT. RAIL, 9.0" LONG	2	2	2	2	2	2	2	2	2	2	2	2	2	2	2	2	2		
9	BRC-002500	END BRACE, WET CELL RACK, 24, 9.0"	2	2	2	2	2	2	2	2	2	2	2	2	2	2	2	2	2		
10	SEE BRACE TABLE	BRACE, CROSS	REFERENCE BRACE TABLE FOR BRACE TYPE AND QTY.																		
11	HEXNUT3/8-16ZINC	HEX NUT, 3/8-16, ZINC	8	8	8	12	12	12	12	16	16	16	16	20	20	20	20	24	24		
12	KIT-003615	INTER. SUPPORT, WET CELL, 3/8 HDWR, 15"	0	0	0	0	0	0	0	1	1	1	1	1	1	1	1	2	2		

- NOTES:
1. EPOXY POWDER COATED FRAMES
 2. STANDARD RAILS AND SEISMIC BRACES ARE GALVANIZED.
 3. REFER TO PAGE 2 FOR FRAME TO FRAME DIMENSIONS DEPENDING ON THE LENGTH OF RACK.
 4. BRACES USED ARE DEPENDENT ON DIMENSIONS BETWEEN FRAMES. REFERENCE PAGE 2 AND BRACE TABLES TO DETERMINE LOCATION OF BRACES DEPENDING ON THE BRACE'S LENGTHS.

UNLESS OTHERWISE SPECIFIED		DRAWN		NAME	DATE	TITLE: SIT SERIES 900-1000, 1 TIER/1 ROW ZONE 4 RACKS
DIMENSIONS ARE IN INCHES TOLERANCES: ANGULAR: MACH ± .5 BEND ±1 TWO PLACE DECIMAL ± .01 THREE PLACE DECIMAL ± .005		CHECKED				
PROJECTION:		ENG APPR				SIZE: C
MATERIAL: SEE NOTE 1		MFG APPR				DWG. NO.: WR233-1T1R Z4
FINISH: SEE NOTE 2		Q.A.				REV: B
USED ON		DO NOT SCALE DRAWING		SCALE: 1:8		WEIGHT: SHEET 1 OF 2

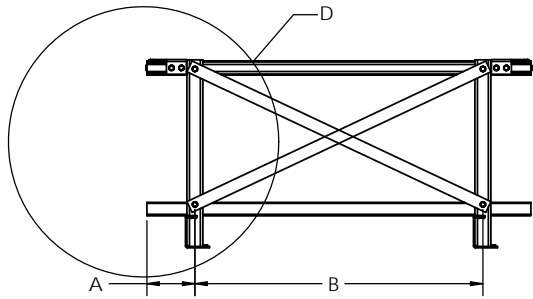

4' - 6' RACKS (2 FRAMES)

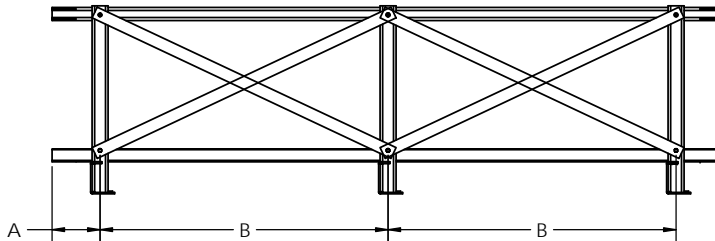

7' - 10' RACKS (3 FRAMES)

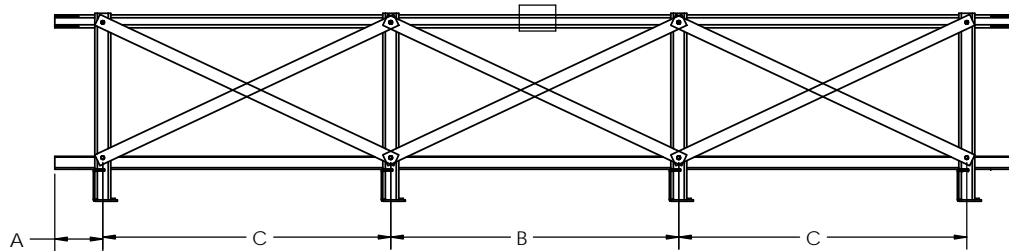

11' - 14' RACKS (4 FRAMES)

INTERMEDIATE SUPPORTS
LOCATE APPROXIMATELY AS SHOWN.
TYP ON RACKS REQUIRED

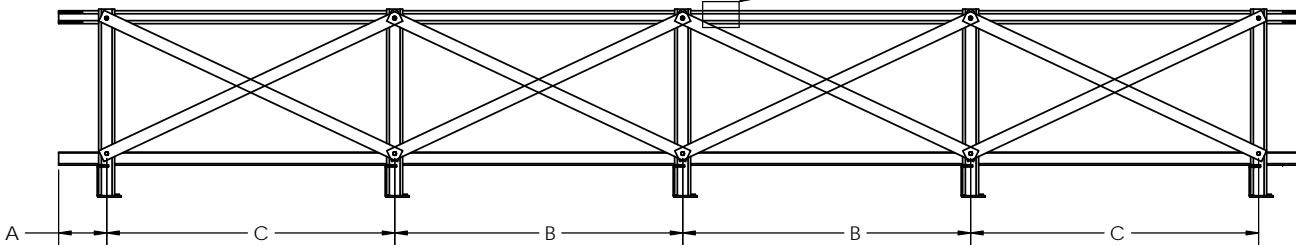

15' - 18' RACKS (5 FRAMES)

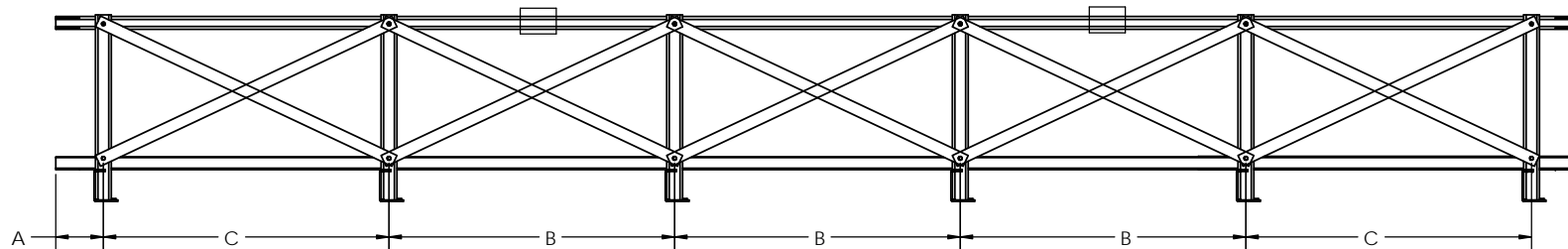

19' - 20' RACKS (6 FRAMES)

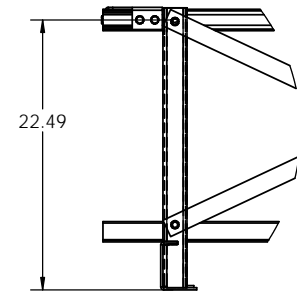

DETAIL D
DETAILS SHOWS HEIGHT PLACEMENT
OF SEISMIC BRACING. THE HEIGHT
IS DEPENDENT ON THE MODEL OF
STT BATTERY