

NOTES:

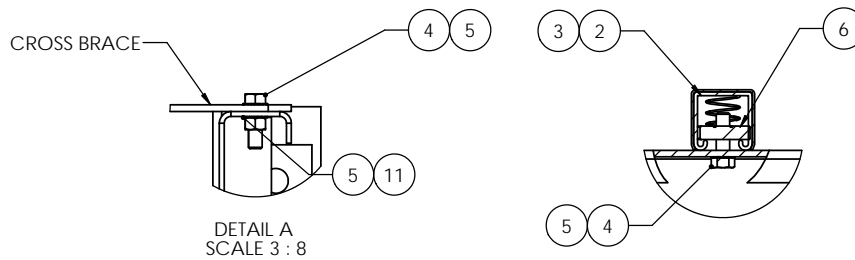
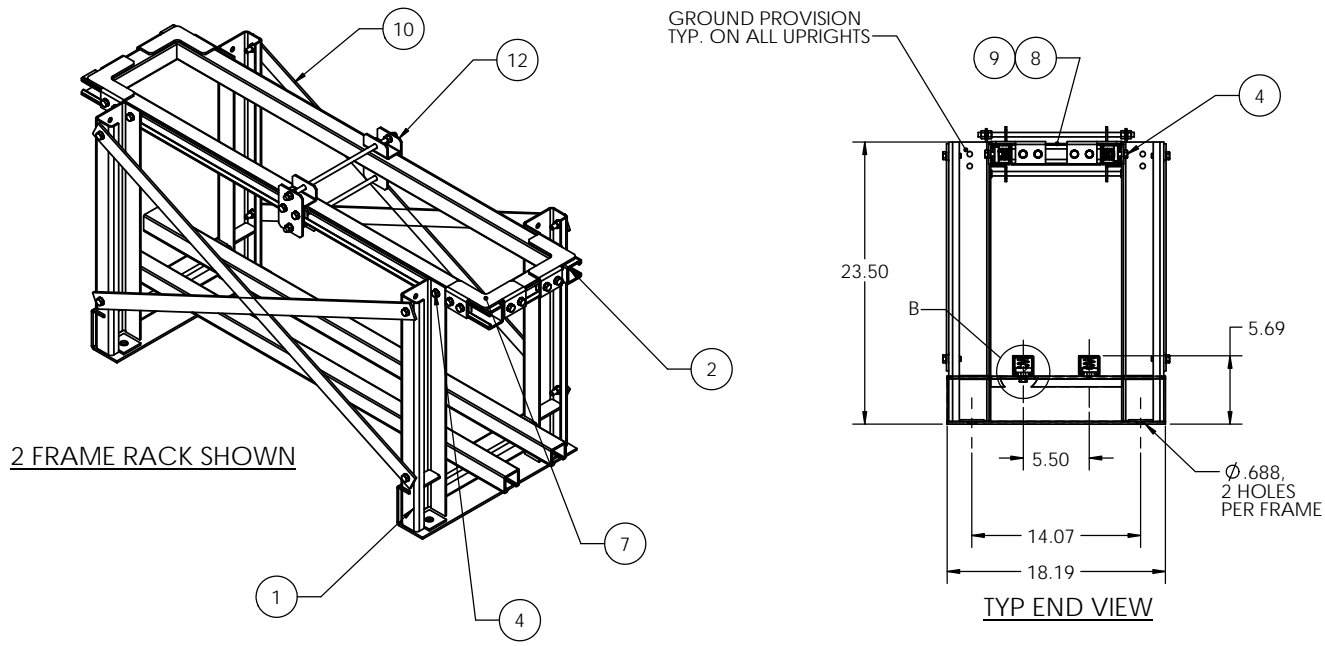

REVISIONS			
REV.	DESCRIPTION	DATE	APPROVED
A	INITIAL RELEASE	7-22-10	RNA
B	UPDATE PER CERTIFICATION CHANGES	8/18/2011	RNA

RACK DIMENSIONS AND OTHER SPECS					
PAR NUMBER	RACK LENGTH DIM "L" (FT)	DIM "A" (IN)	DIM "B" (IN)	DIM "C" (IN)	WEIGHT
WR191-1T1R-48-Z4	4	6	36	N/A	104
WR191-1T1R-60-Z4	5	12	36	N/A	112
WR191-1T1R-72-Z4	6	12	48	N/A	122
WR191-1T1R-84-Z4	7	6	36	N/A	164
WR191-1T1R-96-Z4	8	12	36	N/A	172
WR191-1T1R-108-Z4	9	6	48	N/A	184
WR191-1T1R-120-Z4	10	12	48	N/A	192
WR191-1T1R-132-Z4	11	12	36	36	237
WR191-1T1R-144-Z4	12	12	48	36	247
WR191-1T1R-156-Z4	13	6	48	48	259
WR191-1T1R-168-Z4	14	12	48	48	267
WR191-1T1R-180-Z4	15	6	48	36	310
WR191-1T1R-192-Z4	16	12	48	36	318
WR191-1T1R-204-Z4	17	6	48	48	330
WR191-1T1R-216-Z4	18	12	48	48	338
WR191-1T1R-228-Z4	19	6	48	36	385
WR191-1T1R-240-Z4	20	12	48	36	393

BRACE TABLE			
RACK MODEL	RACK LENGTH (FT)	BRACE P/N	
		BRC-001800	BRC-003600
WR191-1T1R-48-Z4	4	4	N/A
WR191-1T1R-60-Z4	5	4	N/A
WR191-1T1R-72-Z4	6	N/A	4
WR191-1T1R-84-Z4	7	8	N/A
WR191-1T1R-96-Z4	8	8	N/A
WR191-1T1R-108-Z4	9	N/A	8
WR191-1T1R-120-Z4	10	N/A	8
WR191-1T1R-132-Z4	11	12	NA
WR191-1T1R-144-Z4	12	8	4
WR191-1T1R-156-Z4	13	N/A	12
WR191-1T1R-168-Z4	14	N/A	12
WR191-1T1R-180-Z4	15	8	8
WR191-1T1R-192-Z4	16	8	8
WR191-1T1R-204-Z4	17	N/A	16
WR191-1T1R-216-Z4	18	N/A	16
WR191-1T1R-228-Z4	19	8	12
WR191-1T1R-240-Z4	20	8	12

PARTS LIST																				
ITEM NO.	PART NUMBER	DESCRIPTION	4'	5'	6'	7'	8'	9'	10'	11'	12'	13'	14'	15'	16'	17'	18'	19'	20'	
1	FRM-058300	FRAME, 1 TIER, ZONE 4, STI2V 700-800	2	2	2	3	3	3	3	4	4	4	4	5	5	5	5	6	6	
2	BTR-000300	RAIL, BATTERY, 1.625 X 1.625 X "L"	4	4	4	4	4	4	4	4	4	4	4	4	4	4	4	4	4	
3	MIS-000300	PLASTIC COVER, BATT. RAIL, "L"	4	4	4	4	4	4	4	4	4	4	4	4	4	4	4	4	4	
4	HEXBOLT3/8-16X1-1/4ZINC	HBOLT 0.3750-16x1-1/4", Z.P.	32	32	32	40	40	40	40	48	48	48	48	56	56	56	56	64	64	
5	EXTTOOTHWASHER3/8ZC	3/8" EXTERNAL TOOTH LOCK WASHER, Z.P.	40	40	40	52	52	52	64	64	64	64	64	76	76	76	76	88	88	
6	P1008	NUT, UNISTRUT, 3/8-16	24	24	24	28	28	28	28	32	32	32	32	36	36	36	36	40	40	
7	BKT-000901	BRACKET, SHORT, WET CELL RACKS, 1/2" HDWR	4	4	4	4	4	4	4	4	4	4	4	4	4	4	4	4	4	
8	MIS-001900	PLASTIC COVER, BATT. RAIL, 7.4" LONG	2	2	2	2	2	2	2	2	2	2	2	2	2	2	2	2	2	
9	BRC-002200	END BRACE, WET CELL RACK, Z4, 7.4"	2	2	2	2	2	2	2	2	2	2	2	2	2	2	2	2	2	
10	SEE BRACE TABLE	BRACE, CROSS	REFERENCE BRACE TABLE FOR BRACE TYPE AND QTY.																	
11	HEXNUT3/8-16ZINC	HEX NUT, 3/8-16, ZINC	8	8	8	12	12	12	12	16	16	16	16	20	20	20	20	24	24	
12	KIT-003613	INTER. SUPPORT, WET CELL, 3/8 HDWR, 13"	0	0	0	0	0	0	0	1	1	1	1	1	1	1	1	1	2	2

- NOTES:
1. EPOXY POWDER COATED FRAMES
 2. STANDARD RAILS AND SEISMIC BRACES ARE GALVANIZED.
 3. REFER TO PAGE 2 FOR FRAME TO FRAME DIMENSIONS DEPENDING ON THE LENGTH OF RACK.
 4. BRACES USED ARE DEPENDENT ON DIMENSIONS BETWEEN FRAMES. REFERENCE PAGE 2 AND BRACE TABLES TO DETERMINE LOCATION OF BRACES DEPENDING ON THE BRACE'S LENGTHS.

UNLESS OTHERWISE SPECIFIED			
DIMENSIONS ARE IN INCHES			
TOLERANCES:			
ANGULAR: MACH ± .5 BEND ± 1			
TWO PLACE DECIMAL ± .01			
THREE PLACE DECIMAL ± .005			
DRAWN	NAME	DATE	TITLE:
CHECKED		7-7-10	SIT SERIES 700-800, 1 TIER /1 ROW
ENG APPR			ZONE 4 RACKS
MFG APPR			SIZE DWG. NO. REV
QA			C WR191-1T1R Z4-SPEC B
USED ON	SEE NOTE 2		SCALE: 1:8 WEIGHT: SHEET 1 OF 2
DO NOT SCALE DRAWING			

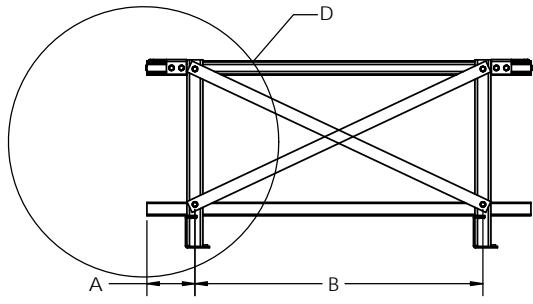

4' - 6' RACKS (2 FRAMES)

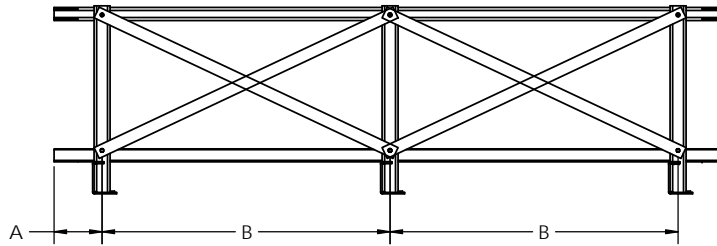

7' - 10' RACKS (3 FRAMES)

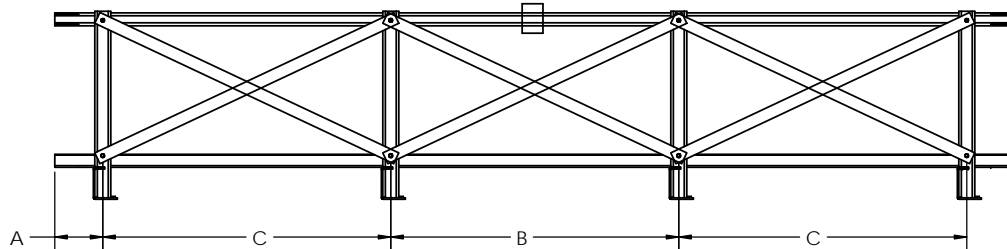

11' - 14' RACKS (4 FRAMES)

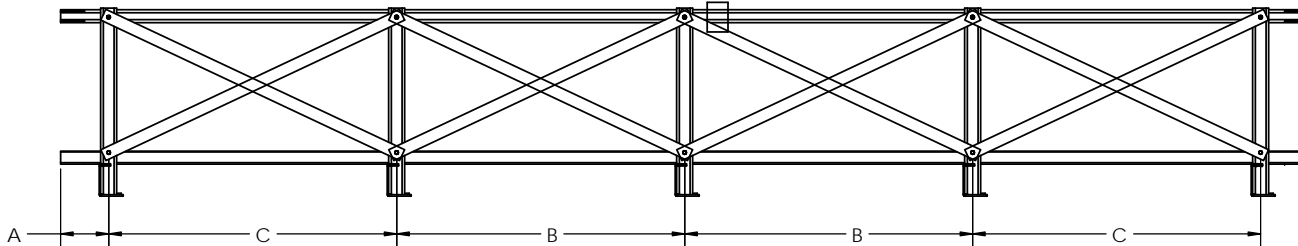

15' - 18' RACKS (5 FRAMES)

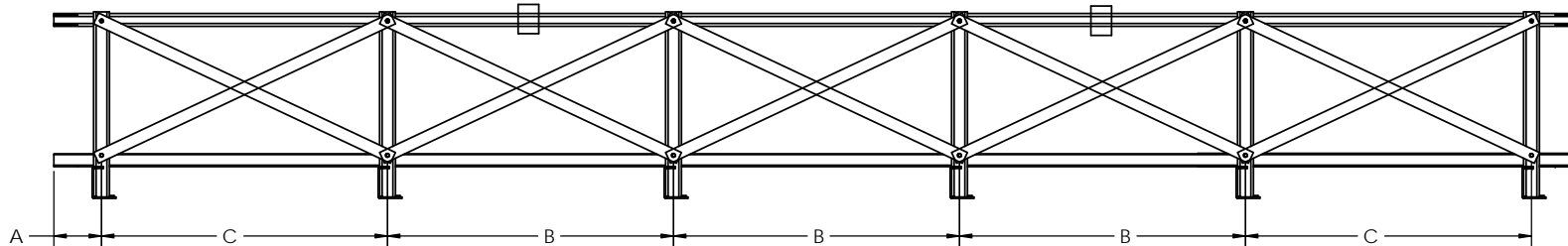

19' - 20' RACKS (6 FRAMES)

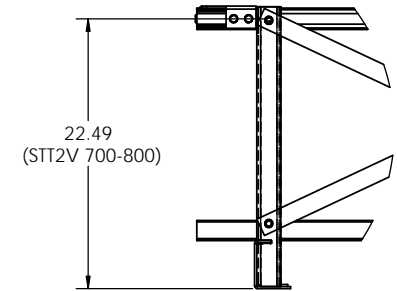

DETAIL D
DETAILS SHOWS HEIGHT PLACEMENT
OF SEISMIC BRACING. THE HEIGHT
IS DEPENDENT ON THE MODEL OF
STT BATTERY

UNLESS OTHERWISE SPECIFIED:				TITLE:	
DIMENSIONS ARE IN INCHES				DRAWN	
TOLERANCES:				NAME	
ANGULAR: MACH ± .5 BEND ± 1				DATE	
TWO PLACE DECIMAL ± .01				7-7-10	
THREE PLACE DECIMAL ± .005				STT SERIES, 700-800, 1 TIER/1ROW	
PROJECTION:		CHECKED		ZONE 4 RACKS	
MATERIAL:		ENG APPR:		SIZE DWG. NO.	
SEE NOTE 1		MFG APPR:		C WR191-1T1R-Z4	
FINISH:		C.A.		REV	
SEE NOTE 2				B	
DO NOT SCALE DRAWING				SCALE: 1:8 WEIGHT: SHEET 2 OF 2	
USED ON					