

OWNER'S MANUAL 193111-081

Issued March 14, 2008

IMPORTANT: Read these instructions before installing, operating, or servicing this system.

BATTERY-MATE 60

**Silicon Diode Ferroresonant
Transformer type
Battery Charger**

DO NOT DESTROY

AMETEK/PRESTOLITE POWER , TROY, OHIO 45373-1099, U.S.A.

INTRODUCTION	1
How to use this Manual	1-1
Equipment Identification.....	1-1
Receipt of Equipment	1-1
SAFETY INSTRUCTIONS AND WARNINGS	2
DESCRIPTION OF EQUIPMENT	3
Charger	3-1
Charge Control	3-1
INSTALLATION	4
Location	4-1
Grounding	4-1
Line Voltage Changeover Instructions	4-1
Line Connections to Battery Charger	4-2
Charging Cable Connectors.....	4-3
Pre-operation Checks	4-3
OPERATION	5
Preliminary	5-1
Normal or Daily Charge	5-1
Equalize or Weekend Charge	5-1
Manual Stop.....	5-2
Battery Discrimination	5-2
Refresh Charge	5-2
Backup Timer Shutdown.....	5-2
Battery Disconnect Shutdown.....	5-3
Low Current Shutdown	5-3
AC Power Fail.....	5-3
MAINTENANCE	6
Inspection and Cleaning	6-1
Lubrication	6-1
Charging Rate Adjustment.....	6-1
Fuse Replacement.....	6-2
Silicon Diode Testing	6-2
Capacitor Testing.....	6-3
TROUBLESHOOTING	7
PARTS LIST	8
DIAGRAMS	
WARRANTY	

INTRODUCTION

How To Use This Manual

IMPORTANT: It is especially important that all charger internal components be kept clean and dry, and all electrical connections as tightened as instructed in the Maintenance chapter of this manual. Replace any precautionary or instruction label that cannot be easily read.

To ensure safe operation, read the entire manual, including the chapter on Safety Instructions and Warnings.

Throughout this manual, the words **WARNING**, **CAUTION**, and **NOTE** may appear. Pay particular attention to the information provided under these headings. These special annotations are easily recognized as follows:

WARNING gives information regarding possible personal injury. Warnings will be enclosed in a box such as this.

CAUTION refers to possible equipment damage. Cautions will be shown in bold type.

NOTE offers helpful information concerning certain operating procedures. Notes will be shown in italics.

Equipment Identification

The unit's identification number (specification, model, serial number) usually appears on a nameplate attached to the front panel.

Receipt Of Equipment

When you receive the equipment, check it against the invoice to make sure it is complete and inspect the equipment for possible damage due to shipping. If there is any damage, notify the carrier immediately to file a claim. Furnish complete information concerning damage claims or shipping errors to the company shown on the cover of this manual. Include all equipment identification numbers and group part numbers (if any) as described above along with a full description of the parts in error.

Additional copies of this manual may be purchased by contacting the company shown on the cover of this manual. Include the Owner's Manual number and equipment identification numbers.

SAFETY INSTRUCTIONS AND WARNINGS

FOR OPERATION OF BATTERY CHARGING EQUIPMENT

IMPORTANT – READ AND UNDERSTAND THESE INSTRUCTIONS. DO NOT LOSE THEM. ALSO READ OPERATING/INSTRUCTION MANUAL BEFORE INSTALLING, OPERATING, OR SERVICING THIS EQUIPMENT.

A. General

Battery charging products can cause serious injury or death, or damage to other equipment or property, if the operator does not strictly observe all safety rules and take precautionary actions.

Safe practices have developed from past experience in the use of charging equipment. These practices must be learned through study and training before using this equipment. Anyone not having extensive training in battery charging practices should be taught by experienced operators.

Only qualified personnel should install, use, or service this equipment.

B. Shock Prevention

Bare conductors, or terminals in the output circuit, or ungrounded, electrically-live equipment can fatally shock a person. To protect against shock, have competent electrician verify that the equipment is adequately grounded and learn what terminals and parts are electrically HOT.

The body's electrical resistance is decreased when wet, permitting dangerous current to flow through the body. Do not work in damp area without being extremely careful. Stand on dry rubber mat or dry wood and use insulating gloves when dampness or sweat cannot be avoided. Keep clothing dry.

1. Installation and Grounding of Electrically Powered Equipment – Electrical equipment must be installed and maintained in accordance with the National Electrical Code, NFPA 70, and local codes. A power disconnect switch must be located at the equipment. Check nameplate for voltage and phase requirements.

If a grounding lead (conductor) is part of the power supply cable, be sure to connect it to a properly grounded switch box or building ground. If not part of the supply cable, use a separate grounding lead (conductor). Do not remove a ground prong from any plug. Use correct mating receptacles. Check ground for electrical continuity before using equipment.

The grounding conductor must be of a size equal to or larger than the size recommended by Code or in this manual.

2. Charging Leads – Inspect leads often for damage to the insulation. Replace or repair cracked or worn leads immediately. Use leads having sufficient capacity to carry the operating current without overheating.
3. Battery Terminals – Do not touch battery terminals while equipment is operating.
4. Service and Maintenance – Shut OFF all power at the disconnect switch or line breaker *before* inspecting, adjusting, or servicing the equipment. Lock switch OPEN (or remove line fuses) so that the power cannot be turned ON accidentally. Disconnect power to equipment if it is to be left unattended or out of service.

Disconnect battery from charger. Measure voltage on capacitors and discharge through an insulated screwdriver if there is any voltage reading.

Keep inside parts clean and dry. Dirt and/or moisture can cause insulation failure. This failure can result in high voltage at the charger output.

C. Burn and Bodily Injury Prevention

The battery produces very high currents when short circuited, and will burn the skin severely if in contact with any metal conductor that is carrying this current. Do not permit rings on fingers to come in contact with battery terminals or the cell connectors on top of the battery.

Battery acid is very corrosive. Always wear correct eye and body protection when near batteries.

D. Fire and Explosion Prevention

Batteries give off explosive flammable gases which easily ignite when coming in contact with an open flame or spark. Do not smoke, cause sparking, or use open flame near batteries. Charge batteries only in locations which are clean, dry, and well ventilated. Do not lay tools or anything that is metallic on top of any battery. All repairs to a battery must be made only by experienced and qualified personnel.

E. Arcing and Burning of Connector

To prevent arcing and burning of the connector contacts, be sure the charger is OFF before connecting or disconnecting the battery. (If the charger is equipped with an ammeter, the ammeter should not indicate current flow.) Always connect battery before turning charger ON.

F. Medical and First Aid Treatment

First aid facilities and a qualified first aid person should be available for each shift for immediate treatment of electrical shock victims.

EMERGENCY FIRST AID: Call physician and ambulance immediately. Use First Aid techniques recommended by the American Red Cross.

DANGER: ELECTRICAL SHOCK CAN BE FATAL. If person is unconscious and electric shock is suspected, do not touch person if he or she is in contact with charging leads, charging equipment, or other live electrical parts. Disconnect (open) power at wall switch and then use First Aid. Dry wood, wooden broom, and other insulating material can be used to move cables, if necessary, away from person. IF BREATHING IS DIFFICULT, give oxygen. IF NOT BREATHING, BEGIN ARTIFICIAL BREATHING, such as mouth-to-mouth. IF PULSE IS ABSENT, BEGIN ARTIFICIAL CIRCULATION, such as external heart massage.

IN CASE OF ACID IN THE EYES, flush very well with clean water and obtain professional medical attention immediately.

G. Equipment Warning Labels

Inspect all precautionary labels on the equipment. Order and replace all labels that cannot be easily read.

DESCRIPTION OF EQUIPMENT

Charger

The basic charging circuit is the silicon diode, rectifier-type with ferroresonant transformer (s). This ferroresonant transformer design regulates charging current by allowing the battery to determine its own charge cycle rate in accordance with its state of discharge. It provides a constantly-tapering charge that eliminates the possibility of overcharging, even with line voltage variations of $\pm 10\%$. Three-phase input chargers have two transformers. The charger is internally protected from overload and short circuits.

When charging lead acid batteries, with the same number of cells and ampere-hour capacity as shown on charger nameplate, the charging time will be approximately 10 hours. Batteries of smaller or larger ampere-hour capacities can also be charged, but will require shorter or longer charging, respectively.

Charge Control

The AC500 Control is provided as the standard charger control. It utilizes either a voltage/time (VT) charge termination or a patented $pT/dV/dT$ charge termination technique which eliminates excessive gassing by returning approximately 107% of the amp-hours removed from the battery.

Features of the AC500 Control include manual equalize, manual stop, back-up timer protection, two charge termination methods, 80% voltage point selection, high and low battery voltage discrimination, and AC power fail recovery.

The AC500 Control is "matched" to the output voltage of the charger by means of a printed circuit board mounted DIP switch. It will operate on 6, 12, 18, 24, 36, and "optional" cell batteries. "Optional" is provided to accommodate batteries between 6 and 36 cells that are not listed above.

The status of a normal charge cycle is indicated by the four LEDs on the front panel. The "80% Charged" LED will light when the battery voltage reaches the 80% charged voltage. This voltage may be 2.37 volts/cell or 2.45 volts/cell nominal, depending on the status of DIP switch S1-7. See the AC500 Setup chapter of this manual. The "Charge Complete" LED will light only if the battery has completed the charge cycle and is ready for use. The "Abnormal Shutdown" LED will light if the charger terminates a charge prematurely. See the Troubleshooting chapter of this manual to determine the cause of the fault. The "Equalize" LED will light solid when an equalize charge is requested by pressing the EQUALIZE push button. The "Equalize" LED will flash when the charger is equalizing the battery.

WARNING: Do not connect a battery to this charger if any LED is lit. Do not disconnect a battery from this charger while a charge is in progress. Otherwise, arcing and burning of connector parts or a battery explosion may result. Batteries produce explosive gases. Keep sparks, flame, and cigarettes away. Ventilate when charging in an enclosed area. Always shield eyes when working near batteries.

INSTALLATION

Location

For best operating characteristics and longest unit life, take care in selecting an installation site. Avoid locations exposed to high humidity, dust, high ambient temperature, or corrosive fumes. Moisture can condense on electrical components, causing corrosion or shorting of circuits (especially when dirt is also present).

Adequate air circulation is needed at all times in order to assure proper operation. Provide a minimum of 6 inches of free air space at rear and sides of the unit. Make sure that ventilation openings are not obstructed.

Always remove the charger shipping skid from the unit before installation. The charger must be installed over a noncombustible surface such as concrete or metal. Keep the charging area clear of all combustible material such as wood, paper, and cloth.

WARNING: SPARKS OR MOLTEN METAL falling through open bottom can cause fire or explosion.

- **Install over noncombustible material such as concrete or metal.**
- **Keep charging area clear of combustible material.**

Grounding

The frame of the power source must be grounded for personnel safety. Where grounding is mandatory under state or local codes, it is the responsibility of the user to comply with all applicable rules and regulations. Where no state or local codes exist, it is recommended that the National Electrical Code be followed.

In addition to the usual function of protecting personnel against the hazard of electrical shock due to fault in the equipment, grounding serves to discharge the static electrical charges which tend to build up on the surfaces of equipment. These static charges can cause painful shock to personnel, and can lead to the erroneous conclusion that an electrical fault exists in the equipment.

If a charger is to be connected to the AC power supply with a flexible jacketed cable, one having a separate grounding conductor should be used. When included in cable assembly, grounding conductor will be green, green with a yellow stripe, or bare.

When connecting input power to charger (as instructed in Line Connection to Battery Charger section of this manual), connect grounding conductor to equipment grounding terminal (stud with a green nut and a cup washer and identified by symbol \equiv), taking care to make a good electrical connection. Connect other end of grounding conductor to the system ground.

If, for any reason, an input cable which does not include a grounding conductor is used, the equipment must be grounded with separate conductor. Minimum size and color coding requirements must be in accordance with any applicable state or local code, or the National Electrical Code.

If metallic armored cable or conduit is used, the metal sheathing or conduit must be effectively grounded as required by state or local code, or the National Electrical Code.

If a system ground is not available, the charger frame must be connected to a driven ground rod (at least 8 ft [2438 mm] long), or to a water pipe that enters the ground not more than 10 ft (3048 mm) from the charger. A grounding conductor must be connected to the rod or pipe in a manner that will assure a permanent and effective ground. The conductor must be sized in accordance with any applicable state or local code, or by the National Electrical Code. If in doubt, use the same size conductor as is used for the conductors supplying power to the charger.

WARNING: ELECTRIC SHOCK HAZARD – Under no circumstance should you use a grounding conductor with a current carrying capacity less than the ampere rating shown in Table 4-1.

Line Voltage Changeover Instructions

1. Determine if the charger is connected for available line voltage. A label located near AC input terminals is marked with the AC voltage for which the charger is factory connected.
2. If charger is not connected correctly, check serial nameplate to determine that charger is equipped to be connected for available line voltage. If charger is suitably equipped, make voltage changeover connections by following instructions on AC INPUT label inside charger.
3. If charger is reconnected, check input fuse (s) ratings with ratings specified on label and replace if necessary.

LINE AMPS	DISCONNECT SWITCH *	BRANCH FUSE SIZE (AMPERES)	COPPER CABLE SIZE AWG **	
			POWER	GROUND
0-2.5	30A	5	No. 14	No. 14
2.6-4.5	30A	7	No. 14	No. 14
4.6-7.5	30A	10	No. 14	No. 14
7.6-12	30A	15	No. 14	No. 14
12.1-16	30A	20	No. 12	No. 12
16.1-18	30A	25	No. 10	No. 10
18.1-22	30A	30	No. 10	No. 10
22.1-24.5	60A	35	No. 8	No. 10
24.6-32.5	60A	40	No. 8	No. 10
32.6-40	60A	50	No. 8	No. 10
40.1-45	60A	60	No. 6	No. 10
45.1-57.5	100A	80	No. 4	No. 8
57.6-78	100A	100	No. 2	No. 8
78.1-102.5	200A	125	No. 2	No. 6
102.6-135	200A	150	No. 1/0	No. 6

Table 4-1 Recommended AC Input and Branch Fusing

The above table (Table 4-1) is based on 75°C (167°F) rated conductors and 40°C (104°F) ambient temperatures. Refer to National Electrical Code (2008) Tables 310-16 corrected to 40°C (104°F).

* For 115, 208, and 230-volt lines, use 250-volt disconnect switch.
 For 440-480, 575-volt lines, use 600-volt disconnect switch.

** Two conductors and ground conductor required for single phase.
 Three conductors and ground conductor required for three phase.

Recommended minimum size of grounding conductors (based on National Electrical Code 2008 – Table 250-95).

CAUTION: INCORRECT CONNECTIONS AND INCORRECT FUSE SIZE can damage this equipment. Follow voltage changeover instructions carefully.

Line Connections to Battery Charger

Follow local code requirements if different than instructions in this manual.

1. Turn charger OFF.
2. Be sure charger is connected correctly for available line voltage as instructed above.
3. On charger nameplate, note the AC input amperes corresponding to the line voltage to which charger is to be connected. Use that ampere value to select the proper disconnect switch, fuse, and power cable sizes from Table 4-1. A "WARNING" label inside charger also lists fuse sizes for each line voltage (circled fuse rating is required for internal line voltage connections made at factory).

4. Route AC power input cable in through knockout provided in side panel of charger cabinet. Securely fasten cable wires to a power input terminal inside charger. Refer to Grounding section of this manual for proper connection of grounding conductor. (Charger cabinet top or side panel, or both, may have to be removed to provide access to terminal block).
5. With disconnect switch (on AC input power line) in "OPEN" or "OFF" position, connect power cable coming from charger, to the switch. Install fuses in switch.

Charging Cable Connectors

If connectors are already attached to charging cables, make sure that they're attached so that positive charger polarity will connect to positive battery terminal.

If connectors must be attached to charging cables, follow instructions supplied with connectors.

CAUTION: Make sure connectors are securely attached to cables (good solder joint or well tightened set screws, whichever is applicable). Be certain that positive charger cable will connect to positive battery terminal. If necessary, trace cables into charger and use supplied connection diagram to determine polarity. The use of a DC voltmeter may show polarity. Improper connections will "blow" output fuse and may cause other damage.

Note: If this charger is equipped with certain optional features, the connector attaching procedure may be modified.

Pre-operation Checks

1. Inspect charger thoroughly for damage; loose screws, nuts, or electrical connections.

<p>WARNING: ELECTRICAL SHOCK HAZARD – Before inspecting or cleaning inside cabinet, turn OFF and remove fuses of disconnect switch (supplying AC power to charger), disconnect battery, and check for voltage on capacitors. Discharge through insulated screwdriver if there is any reading.</p>
--

2. Remove all special tags that are tied to charger. Keep tags with this manual for future reference. Leave all precautionary and instruction labels in place on charger. Carefully read and follow instructions on all tags and labels. Make sure all labels remain visible to anyone operating charger.
3. Make sure all charger cabinet panels are fastened in place, to assure proper flow of ventilating air through cabinet.

OPERATION

Preliminary

1. Make sure that charger is installed and grounded as instructed in this manual.
2. Make sure the charge control is set to the proper cell size via the charge control DIP switch cell selector.
3. Turn on main fused disconnect switch that supplies AC power to charger.
4. Maintain electrolyte level in batteries to be charged, as instructed by battery manufacturer. The volume of electrolyte will expand during the charge. Therefore, to avoid overfilling, do not add water until the battery has received at least an 80% charge. This will usually be reached at the time gassing starts.

Normal or Daily Charge

WARNING: DO NOT connect a battery to this charger if any LED is lit. Do not disconnect a battery from this charger while a charge is in progress; otherwise, arcing and burning of connector parts or a battery explosion may result. Batteries produce explosive gases. Keep sparks, flame and cigarettes away. Ventilate when charging in an enclosed area. Always shield eyes when working near batteries.

1. Insure that battery size matches the charger. (Number of cells and ampere-hour capacity are within charger nameplate rating.)
2. Securely engage the battery and charger connectors.
3. After a 5 second delay (all LED's will be lit), the charger will turn on. The "Charge in Progress" LED will indicate charging current.
4. The "80% Charged" LED will light when the battery on charge reaches the 80% charged voltage.
5. The charger will automatically turn off and the "Charge Complete" LED will light when the charge has finished. The light will remain on until the battery is disconnected from the charger.

NOTE: To disconnect battery from charger before charge is complete, first press the STOP key, then disconnect the battery from the charger.

Equalize or Weekend Charge

The AC500 features Auto Equalize every fifth charge cycle. Closing S1-9 disables the auto equalize feature; and an equalize charge request can be performed by pressing the "Equalize" pushbutton on the control front panel. When Auto Equalize is enabled (S1-9 is open), then the "Equalize" pushbutton cannot be used to request an equalize charge. The AC500 is shipped with auto equalize feature enabled. With auto equalize disabled, an equalize charge can be selected or de-selected for any charge cycle using the sequence below.

1. Insure that battery size matches the charger. (Number of cells and ampere-hour capacity are within charger nameplate rating.)
2. Securely engage the battery and charger connectors.
3. After a 5 second delay (all LED's will be lit), the charger will turn on. The "Charge in Progress" LED will indicate charging current.
4. Press the "Equalize" key. The "Equalize" LED will light solid. Press the key again to cancel the equalize charge.

NOTE: The equalize charge cannot be cancelled once the battery reaches the equalize charging period. Press the STOP key to terminate the charge.

5. The "80% Charged" LED will light when the battery on charge reaches the 80% charged voltage.
6. The battery reaches the normal termination point (pT/dV/dT or VT). However, the battery is charged another 3 hours. The "Equalize" LED will flash during this equalize period.
7. The charger will automatically turn off, and the "Charge Complete" and the "Equalize" LED will light when the equalized charge has finished. The LED's will remain on until the battery is disconnected from the charger.

WARNING: DO NOT connect a battery to this charger if any LED is lit. Do not disconnect a battery from this charger while a charge is in progress; otherwise, arcing and burning of connector parts or a battery explosion may result. Batteries produce explosive gases. Keep sparks, flame and cigarettes away. Ventilate when charging in an enclosed area. Always shield eyes when working near batteries.

Manual Stop

1. To turn the charger off during any part of a charge cycle, press the STOP key. All four LEDs will flash.
2. To restart the charger, disconnect and reconnect the battery. A new charge cycle will begin.

Battery Discrimination

The AC500 Control has the ability to reject batteries with cell sizes that do not match the cell size that the control is set up for (via DIP switch S1-1 through S1-6). If the battery connected to the charger has an average terminal voltage of greater than 2.30 volts/cell, the charger will not start and all 4 LEDs will flash, then the "Charge in Progress" LED will flash (high battery fault indication). If the battery voltage eventually falls below 2.30 volts/cell, the control will begin a normal charge sequence.

If the battery connected to the charger has an average terminal voltage of less than 1.75 volts/cell, the charger will not start and all 4 LEDs will flash, then the "80% Charged" LED will flash (low battery fault indication). If the battery voltage eventually rises above 1.75 volts/cell, the control will start a normal charge sequence. If the battery connected to the charger has a terminal voltage of less than 1.75 volts/cell and the operator wishes to start the charge regardless of this low battery voltage, the charge cycle will start if both the EQUALIZE and the STOP keys are held pushed in until all LEDs go out (approximately 5 seconds). Release the key at this time.

Refresh Charge

In order to guarantee that a fully charged battery is always ready for use, a "Refresh" feature has been incorporated into the AC500 Control. If a battery is left connected to the charger for 72 hours after a "Charge Complete" has been reached, the AC500 will start a charge sequence. The running time of this "Refresh" charge will depend on the depth of self-discharge of the battery.

Backup Timer Shutdown

A backup timer will shut down the charger and all 4 LEDs will flash then the "Charge Complete" LED will flash if the battery on charge does not reach the 80% voltage during the first 10 hours of charging.

Likewise, if the AC500 Control is set to terminate via the pT/dV/dT methodology (DIP switch S1-8 off) and the charger does not reach the termination point within 5 hours after reaching the 80% charged voltage, all 4 LEDs will flash then the "Charge Complete" LED will flash.

WARNING: DO NOT connect a battery to this charger if any LED is lit. Do not disconnect a battery from this charger while a charge is in progress. Otherwise, arcing and burning of connector parts or a battery explosion may result. Batteries produce explosive gases. Keep sparks, flame, and cigarettes away. Ventilate when charging in an enclosed area. Always shield eyes when working near batteries.

Battery Disconnect Shutdown

If the battery is disconnected from the charger during a charge cycle, the charger will be shutdown. All LEDs will be off.

Low Current Shutdown

If the charger output current falls below a predetermined level, a low current shutdown will occur. All 4 LEDs will flash, then the "Equalize" LED will flash.

AC Power Fail

During an AC power failure, the AC500 Control stores key information about the charge cycle. The information is retained by powering some of the control's key components with a battery derived power supply. This causes the control to resume the charge where it left off when the AC power is returned, unaffected timers and equalize requests.

MAINTENANCE

WARNING: ELECTRICAL SHOCK HAZARD — Before inspecting or cleaning inside cabinet, turn OFF and remove fuses of disconnect switch (supplying AC power to charger), disconnect battery, and check for voltage on capacitors. Discharge through insulated screwdriver if there is any reading.

Inspection And Cleaning

For uninterrupted, satisfactory service from this charger, it's necessary to keep unit clean, dry, and well ventilated. At least every three months, or more often as necessary, wipe and blow out all dirt from unit's interior components, with clean, dry air of not over 25 psi (172 kPa) pressure. Use a hand bellows if compressed air isn't available.

Check and tighten all electrical connections as necessary to eliminate unnecessary losses and to avoid subsequent trouble from overheating or open circuits. Check for broken wiring or damaged insulation on wiring.

WARNING: ELECTRICAL SHOCK HAZARD — Failure to keep internal parts clean and dry may allow transformer (s) to short out, causing secondary circuits to carry dangerously high voltage.

Be sure to replace all charger cabinet panels after any servicing, to assure proper flow of cooling air through unit and to protect internal components.

WARNING: ELECTRICAL SHOCK HAZARD — All cabinet panels must be replaced to protect personnel from contact with hazardous voltages.

Lubrication

None required.

Charging Rate Adjustment

Although it is normally not required, the charging rate can be adjusted to accommodate unusually high or low AC power line voltages, unusually high or low ambient temperatures, or aged battery.

A rate adjustment is necessary if battery consumes more water than normal or if its specific gravity after a normal (daily) charge is not within 10 points of its gravity after a weekend (equalizing) charge.

CAUTION: Before adjusting charging rate, make sure that bad connections or damage to charger isn't affecting charging process. Also make sure proper charging procedure has been followed (thoroughly read Operation chapter of this manual).

WARNING: ELECTRICAL SHOCK HAZARD — Before adjusting charging rate, turn OFF and remove fuses of disconnect switch (supplying AC power to charger), disconnect battery, and check for voltage on capacitors. Discharge through insulated screwdriver if there is any reading.

	Yellow Jumper	Orange Lead	Charger Output
	8 to 9	to 12	Maximum Output ↑ Higher Output ↓ Lower Output Minimum Output
	8 to 10	to 12	
	8 to 9	to 11	
	8 to 10	to 11	
	8 to 9	to 10	
	8 to 9	to 8	
	8 to 10	to 9	
	8 to 11	to 10	
	8 to 11	to 9	
	8 to 12	to 10	
8 to 12	to 9		

Table 6-1 Charging Rate Adjustment Table

1. Locate charging rate adjustment label inside charger cabinet (same as Table 6-1). The factory set charging rate is indicated on this label by circles around terminal numbers to which YELLOW jumper and ORANGE lead were connected.
2. Locate YELLOW jumper and ORANGE lead on each transformer terminal block present in your unit (one transformer for single-phase, two for three-phase).
3. Mark present location of YELLOW jumper and ORANGE lead on charger rate adjustment label and on Table 6-1 if different from that marked by factory.
4. Reconnect YELLOW jumper and ORANGE lead to the terminals giving the desired change of charging rate, as shown in Table 6-1.

CAUTION: Do not change connections more than one step before observing effect on charging rate. On fully charged battery (approx. 1.270 to 1.290 specific gravity), rate should not exceed 34% of "MAX AMPS" on charger nameplate. On fully discharged battery (approx. 1.140 specific gravity), rate should not exceed 110% of "MAX AMPS".

On three-phase chargers, both transformer terminal blocks must be identically connected.

Fuse Replacement

The silicon diodes in this charger are protected by a "fast-clearing" type fuse.

CAUTION: The use of any other type fuse besides the "fast-clearing" type may cause damage to silicon diodes.

Silicon Diode Testing

WARNING: ELECTRICAL SHOCK HAZARD — Before checking electrical components, turn OFF and remove fuses of disconnect switch (supplying AC power to charger), disconnect battery, and check for voltage on capacitors. Discharge through insulated screwdriver if there is any reading.

1. Disconnect one diode lead to isolate diode from electrical circuitry.
2. Use a good quality ohmmeter (preferably one having a mid-scale value of approximately 50 ohms) to measure resistance values.
3. Zero ohmmeter on R x 1 scale.
4. Record indicated resistance while placing either ohmmeter lead on threaded end of diode and other ohmmeter lead on diode lead.
5. Reverse ohmmeter leads on diode and record indicated resistance.
6. Consider diode good if one resistance reading is infinitely (or very) high and the other is extremely low.

NOTE: An acceptable low resistance value or range of values can't be given because of different readings from different ohmmeters, and differences in diodes of the same rating.

Capacitor Testing

1. Heed WARNING in Silicon Diode Testing section.
2. Disconnect capacitor and connect leads of ohmmeter (set to highest scale) to capacitor terminals.

3. If capacitor is good, pointer will deflect, indicating capacitor is being charged, followed by a deflection in the opposite direction indicating partial discharge.

If there is no deflection, capacitor is "open" and must be replaced. Also, if meter needle moves and stops at one value, replace capacitor.

Replacement capacitors must be ordered from factory. When ordering, supply serial number of charger and microfarad (MFD) or (μ F) value printed on capacitor.

Troubleshooting

DANGER: ELECTRICAL SHOCK HAZARD — Before checking electrical components, turn OFF and remove fuses of disconnect switch (supplying AC power to charger), disconnect battery, and check for voltage on capacitors. Discharge through insulated screwdriver if there is any reading.

CAUTION: HIGH VOLTAGE FROM TEST EQUIPMENT can damage silicon diodes and other parts. Short silicon diodes with extremely short leads, or disconnect, before applying voltage from a "megger" or other high voltage test equipment.

The following chart contains information which can be used to diagnose and correct unsatisfactory operation or failure of various components of the unit. Each malfunction is followed by a suggested checking or inspection procedure. Refer to Connection/Schematic Diagram in the Diagrams chapter included in this manual.

Troubleshooting Guide

No charging current (Ammeter reads zero)

Check line voltage.

Close fused disconnect switch or repair open circuit.

Check for proper line voltage.

Refer to Line Voltage Changeover instructions in Installation chapter.

Check for blown fuses.

Replace blown fuses. See Table 4-1 for proper fuse sizes.

Check for internal short circuit (diode, winding, wiring).

Repair short circuit, or replace faulty component.

Check for "open" battery circuit.

Clean and tighten connections, especially battery cable connections.

Check Charge Control.

Connect a jumper from the red-white lead of Control Transformer T1 to the red lead of Contactor K1 coil. If charger starts and ammeter shows charging current when a battery is connected, check further for faulty printed circuit card on control and replace as necessary.

Check output circuit fuses. If fuse has blown, check for problem causing fuse to blow.

a. *Reverse battery connections, if polarity is wrong.*

b. *Determine whether a diode is shorted. Refer to Silicon Diode Testing.*

Low charging current at beginning of cycle (battery fully discharged)

Check for failed capacitor (s) (one or more).

*Replace capacitor if can is ruptured or fails test. Refer to Capacitor Testing.
Check charging rate for "too low" adjustment.*

Refer to Charging Rate Adjustment in Maintenance chapter.

Check line voltage for connection to proper input voltage.

Refer to Line Voltage Changeover instructions in Installation chapter.

Check battery for one or more defective cells.

Less than rated output on fully discharged battery (approximately 1/2 rated output)

Check input fuses (one probably blown). Check for either a shorted transformer, or wiring short circuit.

Replace as necessary.

High charging current at beginning of cycle (battery overcharged)

Check charging current for "too high" adjustment.

Refer to Charging Rate Adjustment.

Charger does not shut OFF automatically or start automatically

Check Charge Control. (NOTE: Optional Controls have different diagnostic codes. See Optional Control Manual for details.)

1. If charger does not start automatically, check for 24 volts AC between the red-white lead and red-black lead of control transformer T1. If 24 VAC is present, connect a jumper from the red-white lead of control transformer T1 to the red lead of contactor K1 coil. If charger starts, check further for faulty printed circuit card on control and replace as necessary.
2. If charger does not stop automatically, check to be sure charging voltage rises above 2.37 volts/cell during the cycle. If not, see low charging current or less than rated output above. If battery on-charge voltage rises above 2.37 volts/cell during the cycle, check for defective control printed circuit card.

	HIGH BATT	LOW BATT	LOW CURR	9 HOUR BACKUP TIMER	5 HOUR BACKUP TIMER	MANUAL STOP
80% LED					solid	
CHARGER COMPLETE LED	flash		solid			
ABNORMAL SHUTDOWN LED	flash	flash	flash	flash	flash	solid
EQUALIZE LED	flash	flash				

Table 7-1 AC500 Control LEDs

Flashing Green “Charge Complete” LED
Flashing Red “Abnormal Shutdown” LED
Flashing Yellow “Equalize” LED

High Battery Voltage Indication

Cause #1: Battery number of cells is greater than rated charger number of cells.

Action: Disconnect the battery from the charger and connect to a charger with the same number of cells as the battery.

Cause #2: Battery was just removed from a charger and has an open circuit terminal voltage greater than the high voltage discrimination setting (2.40 volts/cell).

Action: Confirm that the battery matches the rating of the charger and that none of the battery cells are defective. The charge cycle will begin automatically when the battery voltage falls below 2.40 volts/cell.

Cause #3: DIP switch S1 settings on the AC500 Control are incorrect.

Action: Set the DIP switch S1 according to the Setup chapter in this manual.

Solid Red “Abnormal Shutdown” LED

Manual Stop Shutdown Indication

Cause #1: Charge cycle deliberately terminated by pressing STOP button.

CAUTION: BATTERY IS NOT FULLY RECHARGED.

Action: Disconnect battery from charger. Reconnect battery to charger to begin new charge cycle.

Cause #2: Reason for abnormal shutdown is unknown.

Action: Check specific gravities to determine need for additional charge. Disconnect and reconnect battery to charger to begin new charge cycle.

Solid Yellow “80% Charged” LED
Flashing Red “Abnormal Shutdown” LED

5 Hour Backup Timer Shutdown Indication

Cause: Battery did not reach the pT/dV/dT charge termination within 5 hours after the 80% trip point was reached. Check for one of the following:

1. Abnormally high battery counter EMF
 - a. Sulfation on plates
 - b. Loose/corrected inter-cell connectors
 - c. Battery # of cells not matched to charger
2. Incorrect cell switch setting on the control

Flashing Red “Abnormal Shutdown” LED
Flashing Yellow “Equalize” LED

Low Battery Voltage Indication

Cause #1: Battery number of cells is less than rated charger number of cells.

Action: Disconnect the battery from the charger and connect to a charger with the same number of cells as the battery.

Cause #2: Battery is over-discharged and has an open circuit terminal voltage less than the low voltage discrimination setting (1.85 volts/cell).

Action: Confirm that the battery matches the rating of the charger and that none of the battery cells are defective. If it is desired to start the charge cycle on this low voltage battery, then press both buttons for about 5 seconds. The control will ignore the low battery indication and start the charge cycle.

Cause #3: DIP switch S1 settings on the AC500 Control are incorrect.

Action: Set the DIP switch S1 according to the Setup chapter in this manual.

Solid Green “Charge Complete” LED
Flashing Red “Abnormal Shutdown” LED

Low Current Shutdown Indication

Cause: Low charger output current possibly caused by one of the following:

1. Battery # cells greater than charger cell rating
2. Battery amp-hour rating much less than charger amp-hour rating
3. High resistance in charge circuit
 - a. Cable
 - b. Connector
 - c. Intercell connectors
 - d. Internal cell open
4. Sulfated battery
5. Low acid level
6. Rate incorrectly set
7. Blown input fuses
8. Incorrect line voltage/connections
9. Open rectifier diode
10. Defective power transformer
11. Blown output fuse
12. Wiring between control and the charger

Solid Yellow “80% Charged” LED
Solid Green “Charge Complete” LED
Solid Red “Abnormal Shutdown” LED
Solid Yellow “Equalize” LED

NOTE: All four LEDs will be lit solid for about 5 seconds anytime a battery is connected to the control. However, if the LEDs remain lit (probably dimmer than normal), and the charger does not turn on after the 5 second delay, there is a problem.

Improper AC Voltage Input To Control Indication

Cause #1: AC input to charger is incorrect.

Action: Refer to charger owner's manual.

Cause #2: Connections to and/or from the control transformer are incorrect.

Action: Refer to charger owner's manual.

Flashing Red "Abnormal Shutdown" LED

9 Hour Backup Timer Shutdown Indication

Cause: Battery did not reach the 80% voltage point within 9 hours. Check for one of the following:

1. One or more low voltage cells
2. Low charger output
 - a. Incorrect line voltage/connection
 - b. Blown input fuse
 - c. Charge rate set too low
 - d. Defective power transformer
 - e. Battery has incorrect number of cells for charger/control
 - f. High impedance in cable or connector
 - g. Open rectifier diode

PARTS LIST

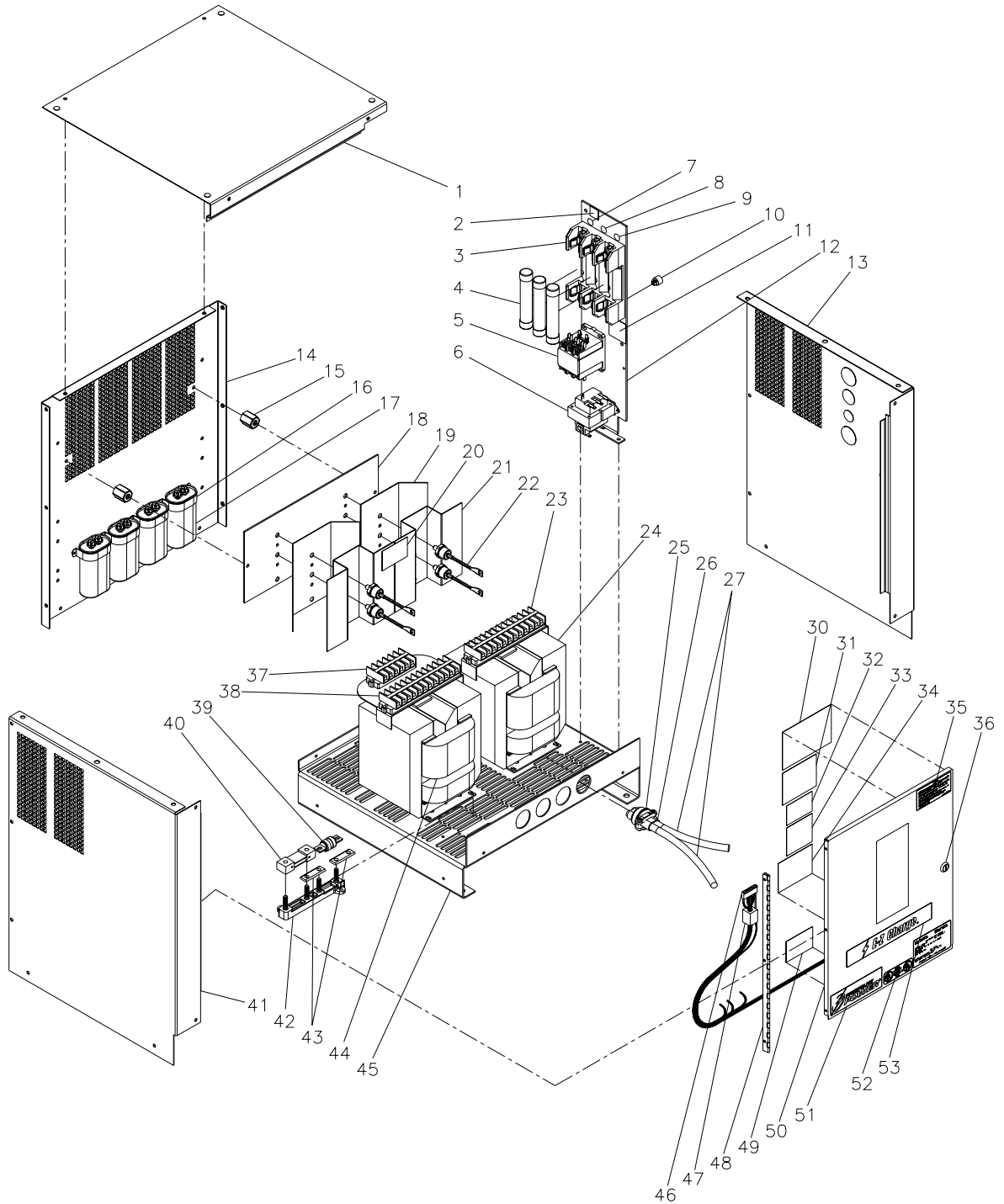

Figure 8-1 3 Phase

ITEM #	PART #	DESCRIPTION
1	194457	Panel, Top
2	405548	Label, Frame Ground
3	See Table	Block, Fuse, Input
4	See Table	Fuse, Input (3 Req'd.)
5	406243-1	Contact, Line
6	See Table	Transformer, Control
7	400092	Label, L1
8	400096	Label, L2
9	400097	Label, L3
10	194827-1	Grommet, Mounting
11	406593	Label, Supply Connections
12	194447	Panel, Interior
13	194565	Panel, Side, Right
14	194454	Panel, Rear
15	404033	Insulator, Heat Sink
16	TRY174-3	Bracket, Mtg., Capacitor
17	See Table	Capacitor, Transformer
18	191191	Heat Sink, Flat
19	191192	Heat Sink, Fin, 45
20	406518	Label, Warning, Heat Sink
21	191193	Heat Sink, Fin, 90
22	193143-1 402832-3	Diode, Silicon, $\leq 1050 \text{ AH}$ (4 Req'd.) Diode, Silicon, $\geq 1260 \text{ AH}$ (4 Req'd.)
23	Call Factory	Block, Terminal, Transformer, T3
24	See Table	Transformer, T3
25	W10080-5	Connector, Strain Relief
26	378234-13	Cover, Neoprene
27	See Table	Cable, Output Charging
28	Not Req'd	
29	Not Req'd	
30	See Table	Label, AC Input
31	194335	Label, Danger, Input Volt. & Fuse
32	191892	Label, Warning, Rain Exposure
33	406434	Label, Warning, Sparks
34	402717	Label, Charging Rate
35	404099	Label, Danger
36	194530	Latch, Door
37	191455	Block, Terminal, Transformer, T2
38	191456	Block, Terminal, Transformer, T2
39	See Table	Fuse, Output
40	See Table	Shunt, Meter
41	194455	Panel, Side, Left
42	193114	Insulator, Shunt / Fuse
43	392458	Bus Bar (2 Req'd.)
44	See Table	Transformer, T2
45	194453	Base, Charger
46	196096	Harness, Interior Panel
47	192266-1	Suppressor, Harness
48	194377	Hinge, Door
49	405026	Label, Fuse, DC Output
50	194458	Door, Hinged
51	196036	Label, Prestolite Power
52	404079	Label, UL and CUL
53	196663	Label, Charger, Battery-Mate 60

**3 PHASE
208/240/480 VOLT UNITS**

MODEL NUMBER	INCOMPLETE SPEC	INPUT FUSE			OUTPUT FUSE	METER SHUNT	INPUT FUSE BLOCK	T2 TRANS	T3 TRANS	CAPS /TRANS	AC INPUT LABEL	CONTROL TRANS	OUTPUT CABLE
		208	240	480									
510H3-12E	500266D-200	W-10386-5	W-10386-5	W-10386-5	Y-1890-3	193125-1	404605-4	193038	193039	TRY-154-4	406461	406247-2	396143-72
600H3-12E	500267D-200	W-10386-5	W-10386-5	W-10386-5	Y-1890-3	193125-1	404605-4	193328	193329	TRY-154-4	406461	406247-2	396143-60
750H3-12E	500268D-200	W-10386-5	W-10386-5	W-10386-5	Y-1890-4	193125-2	404605-4	193177	193178	TRY-154-4	406461	406247-2	396143-60
880H3-12E	500269D-200	W-10386-5	W-10386-5	W-10386-5	Y-1890-4	193125-2	404605-4	193234	193235	TRY-154-6	406461	406247-2	396143-60
965H3-12E	500349D-200	W-10386-6	W-10386-5	W-10386-5	Y-1890-4	193125-2	404605-4	193514	193515	TRY-154-6	406461	406247-2	396143-61
1050H3-12E	500270D-200	W-10386-6	W-10386-5	W-10386-5	Y-1890-5	193125-2	404605-4	193273	193274	TRY-154-4	406461	406247-2	396143-61
1260H3-12E	500310D-200	W-10386-7	W-10386-6	W-10386-5	Y-1890-6	193125-2	404605-4	193364	193365	TRY-154-4	406461	406247-2	396143-61
510H3-18E	500271D-200	W-10386-5	W-10386-5	W-10386-5	Y-1890-3	193125-1	404605-4	193191	193192	TRY-154-4	406461	406247-2	396143-72
600H3-18E	500272D-200	W-10386-5	W-10386-5	W-10386-5	Y-1890-3	193125-1	404605-4	193339	193340	TRY-154-4	406461	406247-2	396143-60
750H3-18E	500273D-200	W-10386-5	W-10386-5	W-10386-5	Y-1890-4	193125-2	404605-4	193043	193044	TRY-154-6	406461	406247-2	396143-60
880H3-18E	500274D-200	W-10386-7	W-10386-6	W-10386-5	Y-1890-4	193125-2	404605-4	193048	193049	TRY-154-6	406461	406247-2	396143-60
965H3-18E	500311D-200	W-10386-7	W-10386-7	W-10386-5	Y-1890-5	193125-2	404605-4	193348	193349	TRY-154-6	406461	406247-2	396143-60
1050H3-18E	500275D-200	W-10386-7	W-10386-7	W-10386-5	Y-1890-5	193125-2	404605-4	193053	193054	TRY-154-6	406461	406247-2	396143-61
1260H3-18E	500276D-200	W-10386-9	W-10386-9	W-10386-9	Y-1890-6	193125-2	404605-5	193289	193290	TRY-154-6	406461	406247-2	396143-61
1400H3-18E	500312D-200	W-10386-9	W-10386-9	W-10386-9	Y-1890-7	193125-3	404605-5	193384	193385	TRY-154-6	406461	406247-2	396143-62
750H3-24E	500277D-200	W-10386-7	W-10386-7	W-10386-5	Y-1890-4	193125-2	404605-4	193263	193264	TRY-154-6	406461	406247-2	396143-60
880H3-24E	500278D-200	W-10386-8	W-10386-7	W-10386-5	Y-1890-4	193125-2	404605-4	193201	193202	TRY-154-1	406461	406247-2	396143-60
965H3-24E	500350D-200	W-10386-8	W-10386-7	W-10386-5	Y-1890-5	193125-2	404605-4	193529	193530	TRY-154-6	406461	406247-2	396143-61
1050H3-24E	500279D-200	W-10386-9	W-10386-9	W-10386-9	Y-1890-5	193125-2	404605-5	193375	193376	TRY-154-6	406461	406247-2	396143-61
1260H3-24E	500313D-200	W-10386-11	W-10386-10	W-10386-9	Y-1890-6	193125-2	404605-5	193393	193394	TRY-154-6	406461	406247-2	396143-61
600H3-40E	500435D-200	W-10386-8	W-10386-8	W-10386-5	Y-1890-3	193125-1	404605-4	194333	194334	TRY-154-6	406461	406247-2	396143-60
750H3-40E	500434D-200	W-10386-10	W-10386-9	W-10386-6	Y-1890-4	193125-2	404605-5	194313	194314	TRY-154-6	406461	406247-2	396143-60

**3 PHASE
480/575 VOLT UNITS**

MODEL NUMBER	INCOMPLETE SPEC	INPUT FUSE		OUTPUT FUSE	METER SHUNT	INPUT FUSE BLOCK	T2 TRANS	T3 TRANS	CAPS /TRANS	AC INPUT LABEL	CONTROL TRANS	OUTPUT CABLE
		480	575									
510H3-12E	500266D-201	W-10386-5	W-10386-5	Y-1890-3	193125-1	404605-4	193072	193073	TRY-154-4	191252	406247-4	396143-72
600H3-12E	500267D-201	W-10386-5	W-10386-5	Y-1890-3	193125-1	404605-4	193332	193333	TRY-154-4	191252	406247-4	396143-60
750H3-12E	500268D-201	W-10386-5	W-10386-5	Y-1890-4	193125-2	404605-4	193228	193230	TRY-154-4	191252	406247-4	396143-60
880H3-12E	500269D-201	W-10386-5	W-10386-5	Y-1890-4	193125-2	404605-4	193238	193239	TRY-154-6	191252	406247-4	396143-60
965H3-12E	500349D-201	W-10386-5	W-10386-5	Y-1890-4	193125-2	404605-4	193518	193519	TRY-154-6	191252	406247-4	396143-61
1050H3-12E	500270D-201	W-10386-5	W-10386-5	Y-1890-5	193125-2	404605-4	193277	193278	TRY-154-4	191252	406247-4	396143-61
1260H3-12E	500310D-201	W-10386-5	W-10386-5	Y-1890-6	193125-2	404605-4	193368	193369	TRY-154-4	191252	406247-4	396143-61
510H3-18E	500271D-201	W-10386-5	W-10386-5	Y-1890-3	193125-1	404605-4	193323	193324	TRY-154-4	191252	406247-4	396143-60
600H3-18E	500272D-201	W-10386-5	W-10386-5	Y-1890-3	193125-1	404605-4	193343	193344	TRY-154-4	191252	406247-4	396143-60
750H3-18E	500273D-201	W-10386-5	W-10386-5	Y-1890-4	193125-2	404605-4	193098	193099	TRY-154-6	191252	406247-4	396143-60
880H3-18E	500274D-201	W-10386-5	W-10386-5	Y-1890-4	193125-2	404605-4	193081	193082	TRY-154-6	191252	406247-4	396143-60
965H3-18E	500311D-201	W-10386-5	W-10386-5	Y-1890-5	193125-2	404605-4	193352	193353	TRY-154-6	191252	406247-4	396143-61
1050H3-18E	500275D-201	W-10386-5	W-10386-5	Y-1890-5	193125-2	404605-4	193092	193093	TRY-154-6	191252	406247-4	396143-61
1260H3-18E	500276D-201	W-10386-5	W-10386-5	Y-1890-6	193125-2	404605-4	193293	193294	TRY-154-6	191252	406247-4	396143-61
1400H3-18E	500312D-201	W-10386-6	W-10386-5	Y-1890-7	193125-3	404605-4	193388	193389	TRY-154-6	191252	406247-4	396143-62
750H3-24E	500277D-201	W-10386-5	W-10386-5	Y-1890-4	193125-2	404605-4	193267	193268	TRY-154-6	191252	406247-4	396143-60
880H3-24E	500278D-201	W-10386-5	W-10386-5	Y-1890-4	193125-2	404605-4	193250	193252	TRY-154-6	191252	406247-4	396143-60
965H3-24E	500350D-201	W-10386-5	W-10386-5	Y-1890-5	193125-2	404605-4	193533	193534	TRY-154-6	191252	406247-4	396143-61
1050H3-24E	500279D-201	W-10386-5	W-10386-5	Y-1890-5	193125-2	404605-4	193379	193380	TRY-154-6	191252	406247-4	396143-61
1260H3-24E	500313D-201	W-10386-6	W-10386-6	Y-1890-6	193125-2	404605-4	193397	193398	TRY-154-6	191252	406247-4	396143-61
600H3-40E	500435D-201	W-10386-5	W-10386-5	Y-1890-3	193125-1	404605-4	194386	194387	TRY-154-6	191252	406247-2	396143-60
750H3-40E	500434D-201	W-10386-6	W-10386-5	Y-1890-4	193125-2	404605-4	194382	194383	TRY-154-6	191252	406247-2	396143-60

3 PHASE DIAGRAMS

3 PHASE

208/240/480 VOLT UNITS

MODEL NO.	SPEC NO.	DIAGRAM	OUTLINE
510H3-12E	500266D-200	192120	194449
600H3-12E	500267D-200	192120	194449
750H3-12E	500268D-200	192120	194449
880H3-12E	500269D-200	192120	194449
965H3-12E	500349D-200	192120	194449
1050H3-12E	500270D-200	192120	194449
1260H3-12E	500310D-200	192120	194449
510H3-18E	500271D-200	192120	194449
600H3-18E	500272D-200	192120	194449
750H3-18E	500273D-200	192120	194449
880H3-18E	500274D-200	192120	194449
965H3-18E	500311D-200	192120	194449
1050H3-18E	500275D-200	192120	194449
1260H3-18E	500276D-200	192120	194449
1400H3-18E	500312D-200	192120	194449
750H3-24E	500277D-200	192120	194449
880H3-24E	500278D-200	192120	194449
965H3-24E	500350D-200	192120	194449
1050H3-24E	500279D-200	192120	194449
1260H3-24E	500313D-200	192120	194449
600H3-40E	500435D-200	192120	194449
750H3-40E	500434D-200	192120	194449

3 PHASE
480/575 VOLT UNITS

MODEL NO.	SPEC NO.	DIAGRAM	OUTLINE
510H3-12E	500266D-201	192954	194449
600H3-12E	500267D-201	192954	194449
750H3-12E	500268D-201	192954	194449
880H3-12E	500269D-201	192954	194449
965H3-12E	500349D-201	192954	194449
1050H3-12E	500270D-201	192954	194449
1260H3-12E	500310D-201	192954	194449
510H3-18E	500271D-201	192954	194449
600H3-18E	500272D-201	192954	194449
750H3-18E	500273D-201	192954	194449
880H3-18E	500274D-201	192954	194449
965H3-18E	500311D-201	192954	194449
1050H3-18E	500275D-201	192954	194449
1260H3-18E	500276D-201	192954	194449
1400H3-18E	500312D-201	192954	194449
750H3-24E	500277D-201	192954	194449
880H3-24E	500278D-201	192954	194449
965H3-24E	500350D-201	192954	194449
1050H3-24E	500279D-201	192954	194449
1260H3-24E	500313D-201	192954	194449
600H3-40E	500435D-201	192954	194449
750H3-40E	500434D-201	192954	194449

193111-081
1 PHASE PARTS LIST

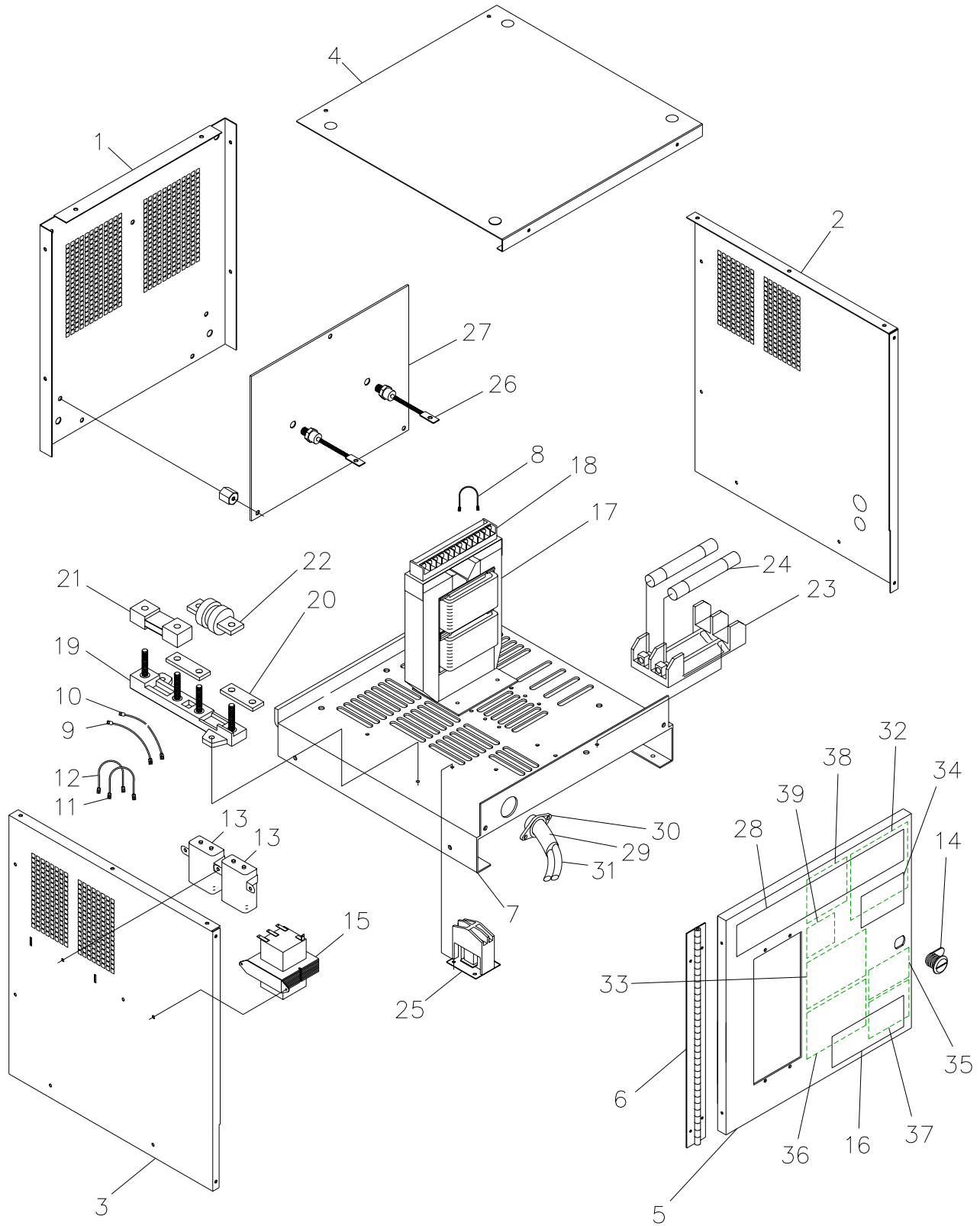

Figure 8-2 1 Phase

ITEM #	PART #	DESCRIPTION
1	197157	Panel, Rear
2	197159	Panel, Side, Right
3	197158	Panel, Side, Left
4	197163	Top
5	197164	Door
6	197165	Hinge
7	197324	Base
8	357205-357	Lead, Yellow (1 Req'd)
9	357205-127	Lead, Orange (1 Req'd)
10	357205-128	Lead, White (1 Req'd)
11	357205-060	Jumper, Orange (2 Req'd)
12	357205-061	Jumper, White (2 Req'd)
13	See Table	Capacitor, Transformer
14	194530	Latch, Door
15	See Table	Transformer, Control
16	196036	Label, Prestolite
17	See Table	Transformer, Power
18	Contact Factory	Block, Terminal
19	193114	Insulator, Fuse & Shunt Ay.
20	392458	Bus Bar
21	See Table	Shunt, Meter
22	See Table	Fuse, Output
23	See Table	Block, Fuse, Input
24	See Table	Fuse, Input
25	See Table	Contact, AC Input
26	402832-003	Diode, Silicon (2 Req'd)
27	197024	Heat Sink
28	196663	Label, Identification
29	378234-013	Cover, Outer Neoprene
30	W10080-005	Connector, Strain Relief
31	See Table	Cable, DC Output
32	See Table	Label, AC Input
33	194335	Label, Danger, AC Volts & Fuse
34	404099	Label, Danger
35	191892	Label, Rain Exposure
36	402717	Label, Charging Rate
37	406434	Label, Input Warning
38	195531	Label, Fuse, DC Output
39	406593	Label, Fuse, AC Input
40	197290	Harness, Wire (For Modular Control)

1 PHASE
208/240/480 VOLT UNITS

MODEL NUMBER	INCOMPLETE SPEC	INPUT FUSE			OUTPUT FUSE	METER SHUNT	INPUT FUSE BLOCK	T2 TRANS	CAPS /TRANS	AC INPUT LABEL	CONTROL TRANS	OUTPUT CABLE
		208	240	480								
380M1-6E	500346E-200	W-10386-5	W-10386-5	W-10386-5	Y-1890-3	193125-1	406207-1	193525	TRY-154-4	406461	406247-2	396143-72
510M1-6E	500280E-200	W-10386-5	W-10386-5	W-10386-5	Y-1890-3	193125-1	406207-1	193306	TRY-154-4	406461	406247-2	396143-72
600M1-6E	500281E-200	W-10386-5	W-10386-5	W-10386-5	Y-1890-3	193125-1	406207-1	193195	TRY-154-4	406461	406247-2	396143-60
250M1-12E	500314E-200	W-10386-5	W-10386-5	W-10386-5	Y-1890-3	193125-1	406207-1	193181	TRY-154-4	406461	406247-2	396143-72
380M1-12E	500315E-200	W-10386-5	W-10386-5	W-10386-5	Y-1890-3	193125-1	406207-1	193184	TRY-154-4	406461	406247-2	396143-72
450M1-12E	500316E-200	W-10386-5	W-10386-5	W-10386-5	Y-1890-3	193125-1	406207-1	193187	TRY-154-4	406461	406247-2	396143-72
510M1-12E	500282E-200	W-10386-5	W-10386-5	W-10386-5	Y-1890-3	193125-1	406207-1	193057	TRY-154-6	406461	406247-2	396143-72
600M1-12E	500283E-200	W-10386-6	W-10386-6	W-10386-5	Y-1890--3	193125-1	406207-1	193255	TRY-154-6	406461	406247-2	396143-60
750M1-12E	500284E-200	W-10386-7	W-10386-6	W-10386-5	Y-1890--4	193125-2	406207-1	193173	TRY-154-6	406461	406247-2	396143-60
880M1-12E	500285E-200	W-10386-8	W-10386-7	W-10386-5	Y-1890--4	193125-2	406207-1	193167	TRY-154-6	406461	406247-2	396143-60
965M1-12E	500347E-200	W-10386-8	W-10386-8	W-10386-5	Y-1890-4	193125-2	406207-1	193510	TRY-154-6	406461	406247-2	396143-60
510M1-18E	500403E-200	W-10386-7	W-10386-6	W-10386-5	Y-1890-3	193125-1	406207-1	194035	TRY-154-4 TRY-154-2	406461	406247-2	396143-72
600M1-18E	500286E-200	W-10386-8	W-10386-7	W-10386-5	Y-1890--3	193125-1	406207-1	193170	TRY-154-6	406461	406247-2	396143-60
750M1-18E	500262E-200	W-10386-9	W-10386-9	W-10386-9	Y-1890--4	193125-2	406207-2	192944	TRY-154-6 TRY-154-2	406461	406247-2	396143-60
880M1-18E	500332E-200	W-10386-10	W-10386-9	W-10386-9	Y-1890--4	193125-2	406207-2	193414	TRY-154-6 TRY-154-2	406461	406247-2	396143-60
510M1-24E	500351E-200	W-10386-8	W-10386-7	W-10386-5	Y-1890-3	193125-1	406207-1	193547	TRY-154-6	406461	406247-2	396143-72
600M1-24E	500352E-200	W-10386-9	W-10386-9	W-10386-9	Y-1890-3	193125-1	406207-2	193552	TRY-154-6	406461	406247-2	396143-60
750M1-24E	500348E-200	W-10386-12	W-10386-10	W-10386-9	Y-1890-4	193125-2	406207-2	193500	TRY-154-6	406461	406247-2	396143-60

1 PHASE
480/575 VOLT UNITS

MODEL NUMBER	INCOMPLETE SPEC	INPUT FUSE		OUTPUT FUSE	METER SHUNT	INPUT FUSE BLOCK	T2 TRANS	CAPS /TRANS	AC INPUT LABEL	CONTROL TRANS	OUTPUT CABLE
		480	575								
510M1-6E	500280E-200	W-10386-5	W-10386-5	Y-1890-3	193125-1	406207-1	193308	TRY-154-4	191655	406247-4	396143-72
600M1-6E	500281E-200	W-10386-5	W-10386-5	Y-1890-3	193125-1	406207-1	193400	TRY-154-4	191655	406247-4	396143-60
250M1-12E	500314E-200	W-10386-5	W-10386-5	Y-1890-3	193125-1	406207-1	193300	TRY-154-4	191655	406247-4	396143-72
380M1-12E	500315E-200	W-10386-5	W-10386-5	Y-1890-3	193125-1	406207-1	193335	TRY-154-4	191655	406247-4	396143-72
450M1-12E	500316E-200	W-10386-5	W-10386-5	Y-1890-3	193125-1	406207-1	193320	TRY-154-4	191655	406247-4	396143-72
510M1-12E	500282E-200	W-10386-5	W-10386-5	Y-1890-3	193125-1	406207-1	193075	TRY-154-6	191655	406247-4	396143-72
600M1-12E	500283E-200	W-10386-5	W-10386-5	Y-1890-3	193125-1	406207-1	193257	TRY-154-6	191655	406247-4	396143-60
750M1-12E	500284E-200	W-10386-5	W-10386-5	Y-1890-4	193125-2	406207-1	193242	TRY-154-6	191655	406247-4	396143-60
880M1-12E	500285E-200	W-10386-5	W-10386-5	Y-1890-4	193125-2	406207-1	193259	TRY-154-6	191655	406247-4	396143-60
965M1-12E	500347E-200	W-10386-5	W-10386-5	Y-1890-4	193125-2	406207-1	193521	TRY-154-6	191655	406247-4	396143-60
510M1-18E	500403E-200	W-10386-5	W-10386-5	Y-1890-3	193125-1	406207-1	194037	TRY-154-4 TRY-154-2	191655	406247-4	396143-72
600M1-18E	500286E-200	W-10386-5	W-10386-5	Y-1890-3	193125-1	406207-1	193197	TRY-154-6	191655	406247-4	396143-60
750M1-18E	500282E-200	W-10386-5	W-10386-5	Y-1890-4	193125-2	406207-1	193095	TRY-154-6 TRY-154-2	191655	406247-4	396143-60
880M1-18E	500332E-200	W-10386-6	W-10386-5	Y-1890-4	193125-2	406207-1	193416	TRY-154-6 TRY-154-2	191655	406247-4	396143-60
510M1-24E	500351E-200	W-10386-5	W-10386-5	Y-1890-3	193125-1	406207-1	193549	TRY-154-6	191655	406247-4	396143-72
600M1-24E	500352E-200	W-10386-5	W-10386-5	Y-1890-3	193125-1	406207-1	193554	TRY-154-6	191655	406247-4	396143-60
750M1-24E	500348E-200	W-10386-6	W-10386-5	Y-1890-4	193125-2	406207-1	193523	TRY-154-6	191655	406247-4	396143-60

1 PHASE
120/208/240 VOLT UNITS

MODEL NUMBER	INCOMPLETE SPEC	INPUT FUSE			OUTPUT FUSE	METER SHUNT	INPUT FUSE BLOCK	T2 TRANS	CAPS /TRANS	AC INPUT LABEL	CONTROL TRANS	OUTPUT CABLE
		120	208	240								
250M1-12E	500314E-204	W-10085-5	W-10085-5	W-10085-5	Y-1890-1	193125-1	405357-1	194048	TRY-154-4	406465	406247-1	396143-72
380M1-6E	500346E-204	W-10085-5	W-10085-5	W-10085-5	Y-1890-1	193125-1	405357-1	193506	TRY-154-4	406465	406247-1	396143-72
380M1-12E	500315E-204	W-10085-7	W-10085-5	W-10085-5	Y-1890-1	193125-1	405357-1	193503	TRY-154-4	406465	406247-1	396143-72

1 PHASE DIAGRAMS

1 PHASE

208/240/480 VOLT UNITS

MODEL NO.	SPEC NO.	DIAGRAM	OUTLINE
380M1-6E	500346E-200	197325	197203
510M1-6E	500280E-200	197325	197203
600M1-6E	500281E-200	197325	197203
250M1-12E	500314E-200	197325	197203
380M1-12E	500315E-200	197325	197203
450M1-12E	500316E-200	197325	197203
510M1-12E	500282E-200	197325	197203
600M1-12E	500283E-200	197325	197203
750M1-12E	500284E-200	197325	197203
880M1-12E	500285E-200	197325	197203
965M1-12E	500347E-200	197325	197203
510M1-18E	500403E-200	197325	197203
600M1-18E	500286E-200	197325	197203
750M1-18E	500262E-200	197325	197203
880M1-18E	500332E-200	197325	197203
510M1-24E	500351E-200	197325	197203
600M1-24E	500352E-200	197325	197203
750M1-24E	500348E-200	197325	197203

1 PHASE

480/575 VOLT UNITS

MODEL NO.	SPEC NO.	DIAGRAM	OUTLINE
510M1-6E	500280E-201	197326	197203
600M1-6E	50028E-201	197326	197203
250M1-12E	500314E-201	197326	197203
380M1-12E	500315E-201	197326	197203
450M1-12E	500316E-201	197326	197203
510M1-12E	500282E-201	197326	197203
600M1-12E	500283E-201	197326	197203
750M1-12E	500284E-201	197326	197203
880M1-12E	500285E-201	197326	197203
965M1-12E	500347E-201	197326	197203
510M1-18E	500403E-201	197326	197203
600M1-18E	500286E-201	197326	197203
750M1-18E	500262E-201	197326	197203
880M1-18E	500332E-201	197326	197203
510M1-24E	500351E-201	197326	197203
600M1-24E	500352E-201	197326	197203
750M1-24E	500348E-201	197326	197203

1 PHASE

120/208/240 VOLT UNIT

MODEL NO.	SPEC NO.	DIAGRAM	OUTLINE
250M1-12E	500314E-204	197325	197203
380M1-6E	500346E-204	197325	197203
380M1-12E	500315E-204	197325	197203

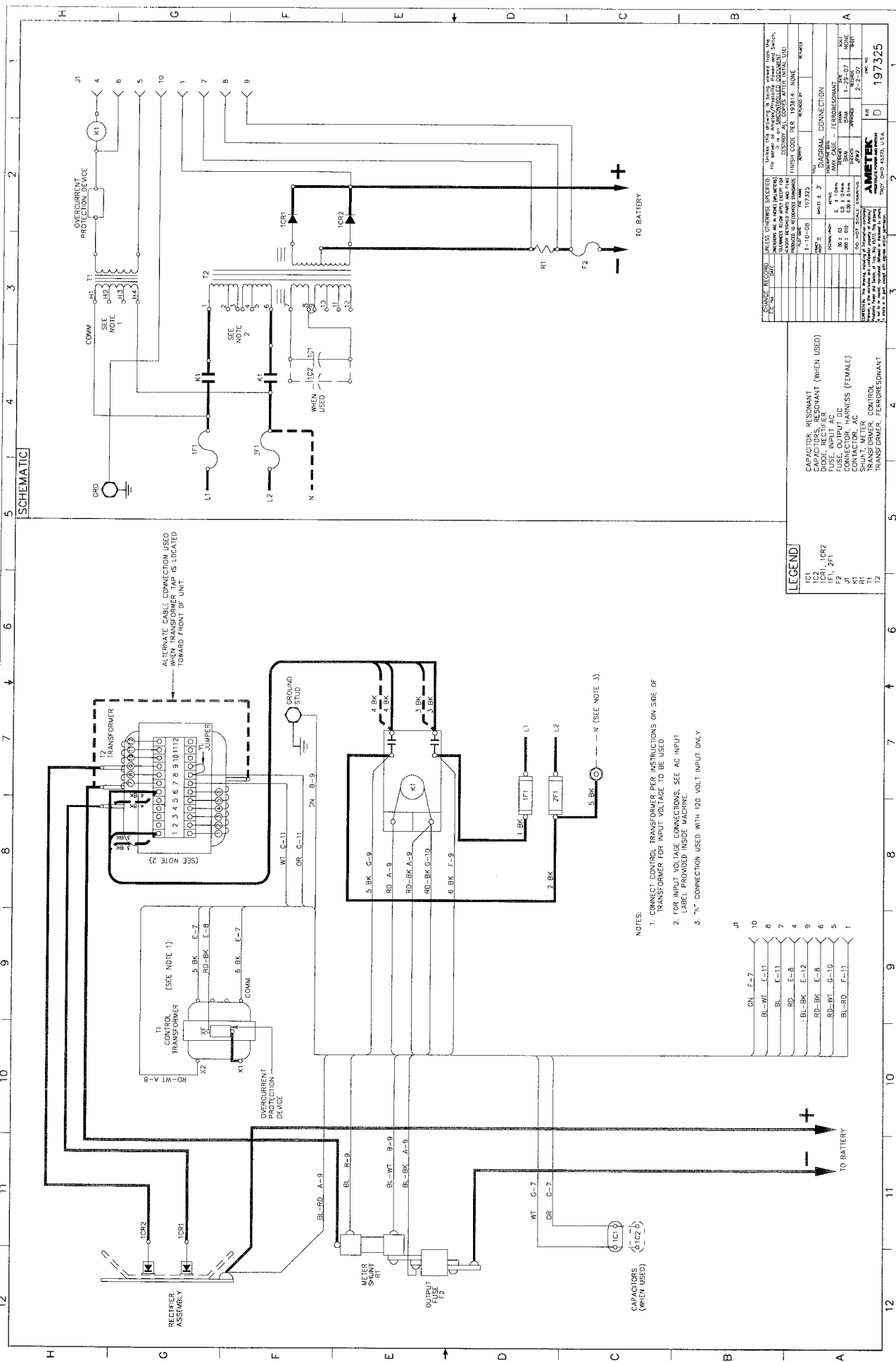

SCHEMATIC

ALTERNATE CABLE CONNECTION USED IF LOCATED TOWARD FRONT OF UNIT.

- NOTES:**
1. CONNECT CONTROL TRANSFORMER PER INSTRUCTIONS ON SIDE OF TRANSFORMER FOR INPUT VOLTAGE TO BE USED.
 2. FOR INPUT VOLTAGE CONNECTIONS, SEE AC INPUT LABEL PROVIDED INSIDE MACHINE.
 3. "N" CONNECTION USED WITH 120 VOLT INPUT ONLY.

J1	GN, F-7	10
	BL, WT, E-11	8
	BL, E-13	7
	RD, E-8	4
	BL, BK, E-12	9
	RD, BK, E-8	6
	RD, WT, G-10	5
	BL, RD, F-11	1

LEGEND

- IC1 CAPACITOR, RESONANT
- ICR1, ICR2 DIODE, RECTIFIER
- F2 FUSE, INPUT AC
- J1 CONNECTOR HARNESS (FEMALE)
- K1 CONTACTOR, AC
- T1 CONTROL TRANSFORMER
- T2 TRANSFORMER, FERRORESONANT

CHANGE RECORD		UNLESS OTHERWISE SPECIFIED	
REV.	DATE	BY	REASON FOR CHANGE
1-10-58	197323		REWORK
DRAWN BY		CHECKED BY	
DESIGNED BY		APPROVED BY	
PROJECT NO.		SCALE	
SHEET NO.		SHEET TOTAL	
1-10-58		197323	
REV. 1		REV. 2	
REV. 3		REV. 4	
REV. 5		REV. 6	
REV. 7		REV. 8	
REV. 9		REV. 10	
REV. 11		REV. 12	
REV. 13		REV. 14	
REV. 15		REV. 16	
REV. 17		REV. 18	
REV. 19		REV. 20	
REV. 21		REV. 22	
REV. 23		REV. 24	
REV. 25		REV. 26	
REV. 27		REV. 28	
REV. 29		REV. 30	
REV. 31		REV. 32	
REV. 33		REV. 34	
REV. 35		REV. 36	
REV. 37		REV. 38	
REV. 39		REV. 40	
REV. 41		REV. 42	
REV. 43		REV. 44	
REV. 45		REV. 46	
REV. 47		REV. 48	
REV. 49		REV. 50	
REV. 51		REV. 52	
REV. 53		REV. 54	
REV. 55		REV. 56	
REV. 57		REV. 58	
REV. 59		REV. 60	
REV. 61		REV. 62	
REV. 63		REV. 64	
REV. 65		REV. 66	
REV. 67		REV. 68	
REV. 69		REV. 70	
REV. 71		REV. 72	
REV. 73		REV. 74	
REV. 75		REV. 76	
REV. 77		REV. 78	
REV. 79		REV. 80	
REV. 81		REV. 82	
REV. 83		REV. 84	
REV. 85		REV. 86	
REV. 87		REV. 88	
REV. 89		REV. 90	
REV. 91		REV. 92	
REV. 93		REV. 94	
REV. 95		REV. 96	
REV. 97		REV. 98	
REV. 99		REV. 100	
REV. 101		REV. 102	
REV. 103		REV. 104	
REV. 105		REV. 106	
REV. 107		REV. 108	
REV. 109		REV. 110	
REV. 111		REV. 112	
REV. 113		REV. 114	
REV. 115		REV. 116	
REV. 117		REV. 118	
REV. 119		REV. 120	
REV. 121		REV. 122	
REV. 123		REV. 124	
REV. 125		REV. 126	
REV. 127		REV. 128	
REV. 129		REV. 130	
REV. 131		REV. 132	
REV. 133		REV. 134	
REV. 135		REV. 136	
REV. 137		REV. 138	
REV. 139		REV. 140	
REV. 141		REV. 142	
REV. 143		REV. 144	
REV. 145		REV. 146	
REV. 147		REV. 148	
REV. 149		REV. 150	
REV. 151		REV. 152	
REV. 153		REV. 154	
REV. 155		REV. 156	
REV. 157		REV. 158	
REV. 159		REV. 160	
REV. 161		REV. 162	
REV. 163		REV. 164	
REV. 165		REV. 166	
REV. 167		REV. 168	
REV. 169		REV. 170	
REV. 171		REV. 172	
REV. 173		REV. 174	
REV. 175		REV. 176	
REV. 177		REV. 178	
REV. 179		REV. 180	
REV. 181		REV. 182	
REV. 183		REV. 184	
REV. 185		REV. 186	
REV. 187		REV. 188	
REV. 189		REV. 190	
REV. 191		REV. 192	
REV. 193		REV. 194	
REV. 195		REV. 196	
REV. 197		REV. 198	
REV. 199		REV. 200	
REV. 201		REV. 202	
REV. 203		REV. 204	
REV. 205		REV. 206	
REV. 207		REV. 208	
REV. 209		REV. 210	
REV. 211		REV. 212	
REV. 213		REV. 214	
REV. 215		REV. 216	
REV. 217		REV. 218	
REV. 219		REV. 220	
REV. 221		REV. 222	
REV. 223		REV. 224	
REV. 225		REV. 226	
REV. 227		REV. 228	
REV. 229		REV. 230	
REV. 231		REV. 232	
REV. 233		REV. 234	
REV. 235		REV. 236	
REV. 237		REV. 238	
REV. 239		REV. 240	
REV. 241		REV. 242	
REV. 243		REV. 244	
REV. 245		REV. 246	
REV. 247		REV. 248	
REV. 249		REV. 250	
REV. 251		REV. 252	
REV. 253		REV. 254	
REV. 255		REV. 256	
REV. 257		REV. 258	
REV. 259		REV. 260	
REV. 261		REV. 262	
REV. 263		REV. 264	
REV. 265		REV. 266	
REV. 267		REV. 268	
REV. 269		REV. 270	
REV. 271		REV. 272	
REV. 273		REV. 274	
REV. 275		REV. 276	
REV. 277		REV. 278	
REV. 279		REV. 280	
REV. 281		REV. 282	
REV. 283		REV. 284	
REV. 285		REV. 286	
REV. 287		REV. 288	
REV. 289		REV. 290	
REV. 291		REV. 292	
REV. 293		REV. 294	
REV. 295		REV. 296	
REV. 297		REV. 298	
REV. 299		REV. 300	
REV. 301		REV. 302	
REV. 303		REV. 304	
REV. 305		REV. 306	
REV. 307		REV. 308	
REV. 309		REV. 310	
REV. 311		REV. 312	
REV. 313		REV. 314	
REV. 315		REV. 316	
REV. 317		REV. 318	
REV. 319		REV. 320	
REV. 321		REV. 322	
REV. 323		REV. 324	
REV. 325		REV. 326	
REV. 327		REV. 328	
REV. 329		REV. 330	
REV. 331		REV. 332	
REV. 333		REV. 334	
REV. 335		REV. 336	
REV. 337		REV. 338	
REV. 339		REV. 340	
REV. 341		REV. 342	
REV. 343		REV. 344	
REV. 345		REV. 346	
REV. 347		REV. 348	
REV. 349		REV. 350	
REV. 351		REV. 352	
REV. 353		REV. 354	
REV. 355		REV. 356	
REV. 357		REV. 358	
REV. 359		REV. 360	
REV. 361		REV. 362	
REV. 363		REV. 364	
REV. 365		REV. 366	
REV. 367		REV. 368	
REV. 369		REV. 370	
REV. 371		REV. 372	
REV. 373		REV. 374	
REV. 375		REV. 376	
REV. 377		REV. 378	
REV. 379		REV. 380	
REV. 381		REV. 382	
REV. 383		REV. 384	
REV. 385		REV. 386	
REV. 387		REV. 388	
REV. 389		REV. 390	
REV. 391		REV. 392	
REV. 393		REV. 394	
REV. 395		REV. 396	
REV. 397		REV. 398	
REV. 399		REV. 400	
REV. 401		REV. 402	
REV. 403		REV. 404	
REV. 405		REV. 406	
REV. 407		REV. 408	
REV. 409		REV. 410	
REV. 411		REV. 412	
REV. 413		REV. 414	
REV. 415		REV. 416	
REV. 417		REV. 418	
REV. 419		REV. 420	
REV. 421		REV. 422	
REV. 423		REV. 424	
REV. 425		REV. 426	
REV. 427		REV. 428	
REV. 429		REV. 430	
REV. 431		REV. 432	
REV. 433		REV. 434	
REV. 435		REV. 436	
REV. 437		REV. 438	
REV. 439		REV. 440	
REV. 441		REV. 442	
REV. 443		REV. 444	
REV. 445		REV. 446	
REV. 447		REV. 448	
REV. 449		REV. 450	
REV. 451		REV. 452	
REV. 453		REV. 454	
REV. 455		REV. 456	
REV. 457		REV. 458	
REV. 459		REV. 460	
REV. 461		REV. 462	
REV. 463		REV. 464	
REV. 465		REV. 466	
REV. 467		REV. 468	
REV. 469		REV. 470	
REV. 471		REV. 472	
REV. 473		REV. 474	
REV. 475		REV. 476	
REV. 477		REV. 478	
REV. 479		REV. 480	
REV. 481		REV. 482	
REV. 483		REV. 484	
REV. 485		REV. 486	
REV. 487		REV. 488	
REV. 489		REV. 490	
REV. 491		REV. 492	
REV. 493		REV. 494	
REV. 495		REV. 496	
REV. 497		REV. 498	
REV. 499		REV. 500	
REV. 501		REV. 502	
REV. 503		REV. 504	
REV. 505		REV. 506	
REV. 507		REV. 508	
REV. 509		REV. 510	
REV. 511		REV. 512	
REV. 513		REV. 514	
REV. 515		REV. 516	
REV. 517		REV. 518	
REV. 519		REV. 520	
REV. 521		REV. 522	
REV. 523		REV. 524	
REV. 525		REV. 526	
REV. 527		REV. 528	
REV. 529		REV. 530	
REV. 531		REV. 532	
REV. 533		REV. 534	
REV. 535		REV. 536	
REV. 537		REV. 538	
REV. 539		REV. 540	
REV. 541		REV. 542	
REV. 543		REV. 544	
REV. 545		REV. 546	
REV. 547		REV. 548	
REV. 549		REV. 550	
REV. 551		REV. 552	
REV. 553		REV. 554	
REV. 555		REV. 556	
REV. 557		REV. 558	
REV. 559		REV. 560	
REV. 561		REV. 562	
REV. 563		REV. 564	
REV. 565		REV. 566	
REV. 567		REV. 568	
REV. 569		REV. 570	
REV. 571		REV. 572	
REV. 573		REV. 574	
REV. 575		REV. 576	
REV. 577		REV. 578	
REV. 579		REV. 580	
REV. 581		REV. 582	
REV. 583		REV. 584	
REV. 585		REV. 586	
REV. 587		REV. 588	
REV. 589		REV. 590	
REV. 591		REV. 592	
REV. 593		REV. 594	
REV. 595		REV. 596	
REV. 597		REV. 598	
REV. 599		REV. 600	
REV. 601		REV. 602	
REV. 603		REV. 604	
REV. 605		REV. 606	
REV. 607		REV. 608	
REV. 609		REV. 610	
REV. 611		REV. 612	
REV. 613		REV. 614	
REV. 615		REV. 616	
REV. 617		REV. 618	
REV. 619		REV. 620	
REV. 621		REV. 622	
REV. 623		REV. 624	
REV. 625		REV. 626	
REV. 627		REV. 628	
REV. 629		REV. 630	
REV. 631		REV. 632	
REV. 633		REV. 634	
REV. 635		REV. 636	
REV. 637		REV. 638	
REV. 639		REV. 640	
REV. 641		REV. 642	
REV. 643		REV. 644	
REV. 645		REV. 646	
REV. 647		REV. 648	
REV. 649		REV. 650	
REV. 651		REV. 652	
REV. 653		REV. 654	
REV. 655		REV. 656	
REV. 657		REV. 658	
REV. 659		REV. 660	
REV. 661		REV. 662	
REV. 663		REV. 664	
REV. 665		REV. 666	
REV. 667		REV. 668	
REV. 669		REV. 670	
REV. 671		REV. 672	
REV. 673		REV. 674	
REV. 675		REV. 676	
REV. 677		REV. 678	
REV. 679		REV. 680	
REV. 681		REV. 682	
REV. 683		REV. 684	
REV. 685		REV. 686	
REV. 687			



WARRANTY

AMETEK/PRESTOLITE POWER “FERRORESONANT” INDUSTRIAL BATTERY CHARGERS

Ametek/Prestolite Power (hereinafter called “Prestolite”) warrants that each new and unused Industrial Battery Charger manufactured and supplied by it is of good workmanship and is free from any inherent mechanical defects, provided that (1) the product is installed and operated in accordance with generally accepted industrial standards and in accordance with the printed instructions of Prestolite, (2) the product is used under normal conditions for which designed, (3) the product is not subjected to misuse, negligence or accident, and (4) the product receives proper care, protection and maintenance under supervision of competent personnel. This warranty is subject to the following provisions:

1. **PRODUCT AND PARTS WARRANTED.** Subject to the exceptions listed below each Industrial Battery Charger is warranted for a specific period of time commencing from the date of it’s shipment by Prestolite, provided the charger is used in accordance with Prestolite’s published performance rating for the unit involved. The exceptions to this warranty are as follows:
 - a) Terms and conditions for warranty coverage:

<u>FERRORESONANT PRODUCTS</u>	ACCU CHARGER	BATTERY MATE 100	BATTERY MATE 80	BATTERY MATE 60
FULL COVERAGE - LABOR, TRAVEL, MILEAGE & PART REPLACEMENT	10-year "full"	10-year "full"	1-year	1-year
PRINTED CIRCUIT BOARD (REPLACEMENT ONLY)				
TRANSFORMER, INDUCTOR, SCR & DIODE (REPLACEMENT ONLY)			9-years additional	9-years additional
TOTAL WARRANTY TERM (YEARS)	10-years	10-years	10-years	10-years

- b) **Warranty Expense Limitation:** The maximum warranty expense Prestolite will incur for any Battery Charger will be limited to the original purchase price of the Battery Charger.
 - c) Primary switch contacts, fuses, bulbs and filters are not warranted unless found to be defective prior to use.
2. **COMMENCEMENT OF WARRANTY TIME PERIODS.** The warranty periods indicated in the Warranty Schedule shall commence on the date of shipment by Prestolite. The ACCU CHARGER and BATTERY MATE 100, 10-year full warranty only applies to chargers manufactured after the 4th quarter of 2004. Units manufactured previous to the 4th quarter will have 1-year full, plus 9-years parts limited coverage.
3. **PERSONS COVERED BY WARRANTY.** Prestolite extends this warranty only to the purchaser of new equipment from Prestolite or one of its authorized distributors. The products purchased under this agreement shall be used exclusively by the buyer and its employees and by no other persons; and therefore there shall be no third party beneficiary to this warranty.
4. **LIMITATION OF REMEDY.** The existence of claimed defects in any product covered by this warranty is subject to Prestolite’s factory inspection and judgement. Prestolite’s liability is limited to repair of any defects found by Prestolite to exist or, at Prestolite’s option, the replacement of the defective product F.O.B. factory after the defective product has been returned by the purchaser at its expense to Prestolite’s shipping place. Replacement and exchange parts will be warranted for the remainder of the original Industrial Battery Charger Warranty or for a period of ninety (90) days, whichever is greater.
5. **USE OF DEFECTIVE PRODUCT.** Continued use of an Industrial Battery Charger after discovery of a defect VOIDS ALL WARRANTIES.
6. **ALTERED EQUIPMENT.** Except as authorized in writing, the warranty specified does not cover any equipment that has been altered by any party other than Prestolite.

THIS WARRANTY IS GIVEN AND ACCEPTED IN LIEU OF ALL OTHER WARRANTIES, WHETHER EXPRESS OR IMPLIED, INCLUDING WITHOUT LIMITATION ANY WARRANTIES OF MERCHANTABILITY OR FITNESS FOR A PARTICULAR PURPOSE, OTHER THAN AS EXPRESSLY SET FORTH HEREIN. IN NO EVENT SHALL PRESTOLITE BE LIABLE FOR ANY ANTICIPATED OR LOST PROFITS, SPECIAL, DIRECT, INDIRECT OR INCIDENTAL DAMAGES, CONSEQUENTIAL DAMAGES, TIME CHARGES OR OTHER COMMERCIAL EXPENSES OR LOSSES, AND BUYER ASSUMES ALL RISK AND LIABILITY RESULTING FROM USE OF THE GOODS. PRESTOLITE DOES NOT AUTHORIZE ANY REPRESENTATIVE OR OTHER PERSON TO ASSUME ON BEHALF OF PRESTOLITE ANY OTHER LIABILITY IN CONNECTION WITH THE SALE OR USE OF THE GOODS SOLD, AND THERE ARE NO ORAL AGREEMENTS OR WARRANTIES COLLATERAL TO OR AFFECTING THIS WRITTEN WARRANTY.

WARNING

At all times, safety must be considered an important factor in the installation, servicing and operation of the product and skilled, qualified technical assistance should be utilized.

AMETEK/PRESTOLITE POWER - TROY, OHIO USA

Data Sheet: 1153
 Index: 030105
 Replaces: Original