

---

# EQUALINK Comprehensive User Manuals

English

**EQUALINK WEB MANAGER CS141**

**SENSORMANAGER & Accessories**

**EQUALINK Battery Analysis & Care**

**System**



# Exponential<sup>TM</sup>

P O W E R



***TEST & MONITORING EQUIPMENT***

## **Copyright Statement for Intellectual Property and Confidential Information**

The information contained in this manual is non-conditional and may be changed without due notice. Although Exponential Power has attempted to provide accurate information within this document, Exponential Power assumes no responsibility for the accuracy of this information.

Exponential Power shall not be liable for any indirect, special, consequential, or accidental damage including, without limitations, lost profits or revenues, costs of replacement goods, loss or damage to data arising out of the use of this document.

Exponential Power the manufacturer of the EQUALINK products undertakes no obligations with this information. The products that are described in this brochure are given on the sole basis of information to its channel partners for them to have a better understanding of the Exponential Power products.

EXPONENTIAL POWER allows its channel partners to transfer information contained in this document to third persons, either staff within their own Company or their own customers, either electronically or mechanically, or by photocopies or similar means. EXPONENTIAL POWER states that the content must not be altered or adapted in any way without written permission from EXPONENTIAL POWER.

It is agreed that all rights, title and interest in the EXPONENTIAL POWER's trademarks or trade names (whether or not registered) or goodwill from time to time of EXPONENTIAL POWER or in any intellectual property right including without limitation any copyright, patents relating to the Products, shall remain the exclusive property of EXPONENTIAL POWER.

EXPONENTIAL POWER will undertake to deal promptly with any complaints about the content of this document. Comments or complaints about the document should be addressed to EXPONENTIAL POWER.

## Introduction

Thank you for trusting the Equalink CS141 Webmanager – the most powerful solution for critical resource management.

Since the CS141 was designed to be a full-fledged, standalone manager, its task is not limited to gathering and sharing information. It also accomplishes numerous tasks in measurement controlling devices dealing directly with critical resource management. Furthermore, the CS141 comes with a full-featured message management system. The CS141 cannot only answer requests coming from higher-level systems - it can also independently inform responsible employees in case of an emergency incident as well as initiating emergency measures based predetermined parameters:

The CS141 can automatically activate basic or advanced emergency systems, shut down servers and workstations. Even automatic restart at predetermined conditions is configurable. In addition to standard technologies such as SNMP and Modbus, the CS141 relies on using the powerful RCCMD software solution. By doing so, even the emergency behavior of complex, fully virtualized server landscapes are realizable.

*Thanks to RFC1628 the CS141 provides more flexibility than ever*

This feature provides new possibilities to integrate third-party UPS systems. Thanks to the new RFC1628 compliant UPS interface, administrators can use the CS141 to poll any SNMP card that supports these standards. Simply use the SNMP-card installed inside your UPS and display the current status natively inside CS141.

This will allow administrators to use the powerful products made by EXPONENTIAL POWER in combination of UPS-Systems that are normally not compatible.

### Note

Due to the fact the CS141 Web Manager can act as a stand-alone system for managing, it can be used flexibly in many areas, even outside the functionality described in this guide. This manual therefore describes the fundamentally implemented functionality according to UPS systems. However, the enormous flexibility and the possibility of communicating with higher and lower-level systems using standardized interfaces allows the adaption to very different possibilities to use.

### About this manual

This manual is more than just a small leaflet – it is written to explain and show all functions of a CS141 – you will notice, this device is very powerful and flexible, you are not limited to use this device as a UPS monitoring card. You can monitor, control, switch or communicate to any parent or child system inside complex IT systems.

This manual is written to show you what you can do with a CS141 and explains how to configure the device – in some cases you will not find some menus described in this manual. Here are some possible reasons:

- The function is not enabled, you need a new firmware.
- Additional devices are needed
- Your CS141 model does not support the function you are looking for
- During the ongoing development progress, sometimes functions will be automated or moved to other menus in order to increase the usability.

This manual is divided into two parts:

- CS141
- EQUALINK

If this is your first CS141, this manual will guide you step by step through all menus and explain nearly everything you need to ensure emergency power and use the notification functions.

What you need to know:

Each model of the CS141 family can handle RCCMD – the CS141 is the RCCMD sender, and the RCCMD software client is the according receiver.

EQUALINK more than “just an option” – it is a powerful battery management solution that may operate as a standalone system. If you are interested in battery management, this chapter is very interesting – but be careful:

Working with batteries inside a UPS system is for experienced or special trained technical who are familiar with all symbols and functions as well as how batteries work. With EQUALINK, you can manage your batteries and optimize your entire UPS solution as well as increasing the battery performance and life time.

# Table of Contents

## Part 1: CS141

### Introduction

- [Differences to the CS121](#)
- [Model Overview](#)
- [Delivery notes](#)
- [Function overview CS141](#)
- [Hardware Layout Appendix](#)
- [Interface Assignment](#)
- [External D-SUB 9-pin male](#)
- [Network integration of the CS141](#)

### Preperations

- [Preparation at the CS41](#)
- [Preparing the Workstation](#)
- [Using DHCP](#)
- [Finding CS141 in networks / MAC address](#)
- [Netfinder](#)

### Basic SettingsConfiguration

- [Installation examples](#)
- [Required Ports](#)
- [Default Passwords](#)
- [Menu structure of the CS141](#)
- [Enhanced and optional menus](#)
- [Differences in operation modes](#)
- [Basic login passwords](#)
- [Setup Wizard](#)
- [IP-address settings and hostname](#)
- [Location and contact settings](#)
- [Provided services](#)
- [Date and time](#)
- [Tutorial: How to set up a custom time server](#)
- [User management](#)
- [System overview](#)
- [Switching to operational mode](#)

### Mail Settings

- [Email settings](#)
- [Advanced Mail Options](#)
- [Test Mail Settings](#)
- [The most common error message](#)
- [Email traps](#)

### Modbus

- [Modbus as single-master-protocol](#)
- [Differences between CS141 Modbus and Professional](#)
- [Pinout of the modbus connection](#)
- [The modbus termination PIN](#)
- [Modbus over RS232/RS485 and Modbus over IP](#)
- [Modbus functions codes](#)
- [Modbus error code table](#)
- [Configuration of modbus](#)
- [Tutorial: Working with MODBUS addresses](#)

### SNMP

- [What is SNMP](#)
- [Setting up SNMP V2](#)
- [Setting up trap receiver](#)
- [Teting Trap receiver with SNMP v2](#)
- [Setting up SNMP v3](#)
- [Using Trap settings with SNMP v3](#)
- [Restarting the SNMP Agent](#)

### Bacnet

- [What is BACnet?](#)
- [Using BACnet with the CS141](#)

### Remote Syslog

- [What is remote syslog](#)
- [Setting up remote syslog](#)
- [Setting up TLS certificates for remote Syslog](#)

[Checklist: remote Syslog problems](#)

## UPS Configuration

[General COM Port Settings](#)  
[The pipe through function](#)  
[Configuration of a UPS](#)  
[Battery Health Level \(%\) feature](#)  
[RFC 1628 UPS Interface](#)  
[UPS monitoring screen](#)  
[UPS functions](#)  
[UPS event handling](#)  
[The intention of a job](#)  
[Managing jobs](#)  
[Available jobs](#)  
[Tutorial: The WOL packet](#)  
[UPS Shutdown definition](#)  
[How to configure a job](#)  
[Time management of jobs](#)  
[Adding jobs to several events](#)  
[Delete jobs](#)  
[Counter Events](#)

## Custom Thresholds

[What are Custom Thresholds](#)  
[Difference Warning/Alarm Levels](#)  
[Example scenario: Custom Thresholds](#)  
[Exemplary excerpt: Custom Thresholds](#)  
[Tutorial: Custom thresholds](#)

## CS141 RCCMD Server

[What is RCCMD](#)  
[Available RCCMD Commands](#)  
[Configuration of RCCMD](#)  
[Setting up the IP address for RCCMD](#)  
[Timing for RCCMD jobs](#)  
[Variables for RCCMD traps](#)

## Sensors and additional devices

[SM T H COM Standalone Sensor](#)  
[General COM Port Settings](#)  
[Setting up a sensor](#)  
[Sensor monitoring screen](#)  
[Event handling for sensors](#)  
[Sensor related system events](#)  
[Setting up a job \\_\\_\\_\\_\\_ for sensor events](#)

### [SENSORMANAGER](#)

[SENSORMANAGER: - Sensor matrix](#)  
[SENSORMANAGER - Adding analog sensors](#)  
[SENSORMANAGER - Sensor event vs matrix event](#)  
[SENSORMANAGER - Setting up the logical connection](#)  
[SENSORMANAGER - Digital inputs](#)  
[SENSORMANAGER - Linking digital inputs and analog sensors](#)  
[SENSORMANAGER - Switching an output](#)  
[SENSORMANAGER - Tutorial: Example scenario: aquarium](#)  
[SENSORMANAGER - Possibilities of the sensor matrix](#)

[Alarm device / buzzer](#)  
[GSM modem](#)  
[CON\\_AUX4 and CON\\_R\\_AUX4](#)

## Scheduler

[How the scheduler works](#)  
[Setting up scheduled Jobs](#)

## Web Server

[Safety instructions](#)  
[HTTP settings](#)  
[PORT settings](#)  
[Force HTTPs](#)  
[HTTP refresh time](#)  
[Simple monitor](#)

## [Tutorial: Creating a PEM-File](#)

### Diagnostics

#### Logfiles

[Event Log](#)  
[Data log](#)  
[Data log Diagram](#)  
[UPS Alert history](#)

#### Tools

[Reboot](#)  
[Tracer](#)  
[Network Scan](#)  
[Privacy Notice: Network Scans](#)  
[Evaluation of data](#)  
[Deleting data](#)  
[Tutorial: Complete data deletion](#)  
[Changing Logo](#)

#### Data backup and updates

[Creating backups](#)  
[Restore configuration from a backup](#)  
[Restore network data](#)  
[Performing a firmware update](#)  
[Changing the OEM firmware](#)

#### If nothing works ...

[Rebooting without login](#)  
[Performing a firmware update directly](#)  
[The rescue mode on the CS141](#)  
[Rescue mode on the CS141 Mini](#)

## Part 2: EQUALINK

### What is EQUALINK?

[What is EQUALINK?](#)  
[What is the advantage of EQUALINK](#)  
[EQUALIZATION: maintain individual charging / discharging](#)  
[Upgrade CS141 to a EQUALINK system](#)

### EQUALINK Installation Guide

**Please read carefully before starting with working on batteries:**

[How to use the EQUALINK manual](#)  
[Fundamentals when working on batteries](#)

### Mandatory additional components

[EQUALINK C module](#)  
[EQUALINK measuring cable](#)  
[EQUALINK bus cable](#)

### Installation examples

[EQUALINK installation examples](#)  
[EQUALINK Bus topology](#)  
[EQUALINK Splitting box](#)  
[Technical data of the EQUALINK Splitting Box](#)  
[EQUALINK installation with two webmanager](#)

### Battery preparation

[Battery preparation](#)  
[Things to be followed during initial installation](#)  
[Connection BC5 measuring cables](#)  
[Connecting BC4B measuring cables](#)  
[Mounting EQUALINK modules](#)  
[How to replace a EQUALINK module](#)

### Initial EQUALINK configuration

[General battery data](#)  
[Number of battery strings](#)  
[Two Jars / Cells per module: Differences when using NiCd](#)

[Tutorial: Creating a PEM-File](#)  
[Basic setting of a EQUALINK module](#)  
[Offset values](#)

[External current sensor](#)  
[Premium feature: Ampere Multiplier](#)  
[Discharge detection: Thresholds for current sensor](#)

#### Initial EQUALINK module setup

[Addressing the EQUALINK modules](#)  
[EQUALINK Programmer restart conditions](#)  
[Defining an address range for module reset](#)  
[General Module setup](#)  
[Address range setup conditions](#)  
[EQUALINK Programmer single mode](#)  
[EQUALINK Error: HW Revision / Calibration error](#)

#### EQUALINK Programmer software tool

[How to connect a computer](#)  
[Preparing EQUALINK installation](#)  
[Operating modes: Automatic mode](#)  
[Operating mode: Manual mode](#)  
[Line check](#)  
[Receive Line Check](#)

#### GX\_R\_AUX

[How it works](#)  
[Connectors](#)  
[Addressing the GX\\_R\\_AUX](#)  
[Configuration of the GX\\_R\\_AUX](#)  
[GX\\_R\\_AUX as battery breaker](#)  
[Normally Open / Normally Closed contacts](#)  
[Defining a job to a EQUALINK event](#)  
[Communicate with third party devices via Outputs / Inputs](#)

#### EQUALINK functions

[EQUALINK](#)  
[Buzzer](#)  
[EQUALINK](#)  
[Relay](#)

#### EQUALINK alarm threshold

[Overvoltage](#)  
[Deep discharge](#)  
[Threshold definition](#)  
[Battery voltage](#)  
[Battery temperature](#)  
[Internal resistance of the battery](#)  
[Maximum voltage deviation between batteries](#)  
[Voltage deviation per string](#)  
[Current deviation per string](#)  
[Alarm delay](#)

#### Battery strings and thermal runaway

[Define EQUALINK battery strings](#)  
[EQUALINK strings vs battery breaker](#)  
[What is a thermal runaway?](#)  
[Mandatory preconditions for EQUALINK thermal runaway functions](#)  
[Max. module temperature difference](#)  
[Max current per string](#)  
[Above conditions are true since](#)

#### Log files

[EQUALINK Log files](#)

#### Initial Start up: Pause Equalizing on Schedule

[What is an unformed battery?](#)  
[Why pause Equalizing during initial start up?](#)  
[How to use a scheduled equalization pause](#)  
[Equalization Pause Example 1](#)  
[Equalization Pause Example 2](#)  
[Equalization Pause Example 3](#)  
[Tutorial: EQUALINK Equalization paused by system](#)  
[EQUALINK Trouble Shooting List](#)



## **Appendix**

[Hardware Layout CS141](#)  
[Interface Description](#)  
[Pin COM2 Mini-DIN 8 pol](#)

### **Modbus addresses**

[Section OEM: ABB/NEWAVE UPS Type Concept Power](#)  
[Section OEM: MASTERGUARD](#)  
[Section OEM: RITTAL PMC Extension](#)  
[Section OEM: Netminder for all LT and MD types](#)  
[Section OEM: Netminder EON](#)  
[Section OEM: Netminder for all other types](#)  
[Section OEM : AEG Protect 3. M 2.0](#)  
[Section OEM: AEG Protect 3.31, 5.31, 8.31](#)  
[Section OEM: AEG Protect 2.33, 3.33, 4.33, 5.33, 8.33, blue](#)  
[Section OEM: POWERTRONIX](#)  
[Section OEM: Socomec UPS](#)  
[Section MHD Modular / Multimatic Modular / AEG Protect 1. Modular, ENIGMA](#)  
[Section Borri 4000 Std. Panel / E-Tec 310 to 380 \(m\) / SALICRU SLC NX/DL/CUBE](#)  
[Section Inform UPS / Pyramid DSP/Online DSP](#)  
[Section Transfer Switches \(All Transfer Switch vendors, except PILLER, STS TUMEL\)](#)  
[Section STS TUMEL Transfer Switch](#)  
[Section OEM TRIMOD](#)  
[Section: EverExceed Inverter](#)

Parameters for UPSMAN Software and EQUALINK

[UPSMAN Status Bytes - Standard Device Status Bits](#)  
[EQUALINKParameters](#)

Last, but not least:

[Copyright and licenses](#)

**Differences to the CS121**

- Complete rework of the menu structure: The simplified interface combines a powerful hardware to provide a significant performance boost:
- The powerful successor of the CS121 allows configuration in real-time - necessary system services will be started or stopped as needed. Therefore, a restart is only necessary in exceptional situations.
- Additional hardcoded user accounts according to specialized tasks:
- Engineer and Guest accounts are provided according to their tasks with limited system rights. On request the new guest account can be set up to allow external technicians a quick information overview without the need of password entry.
- The DIP switches known from the CS121 are no longer required and changed by a comfortable slide switch in the front of the device:

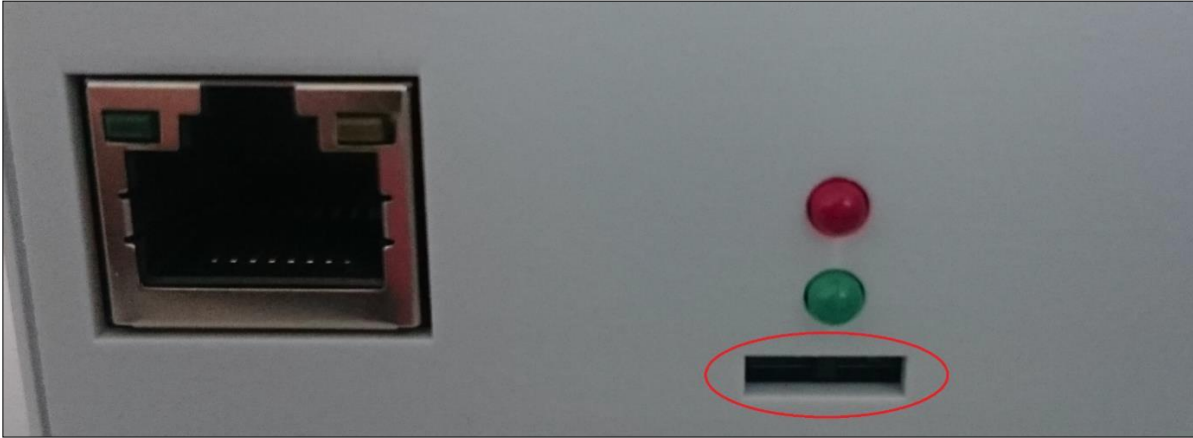

The easy-to-use slide switch will change the hardware configuration. Once the configuration state is chosen, a reboot can be done by the removing power connection or software triggered.

- The firmware update can now be carried out inside a common browser via drag & drop. The need for external tools and FTP access is no longer necessary.
- In case of problems with the firmware, updates or reboots can also be carried out without a complete login. To do this, use a common web browser and enter the IP of the device followed by /update. After a successful admin authentication, the firmware can now be updated and optionally resetted to factory settings.
- By default, auto logout is now enabled. On inactivity, the user is logged out of the system after 15 minutes.
- The power consumption of the CS141 has been reduced by a factor of 10 with a power increase and is well below the predecessor model.

**Note:**

The CS121 has been discontinued in 2015 and replaced by the powerful successor CS141. The Software development was officially discontinued in 2018 - the current firmware state is frozen. Newer UPS systems and models are not available. If you use a CS121 with a specific UPS manufacturer for many years, it may happen that your new UPS model is not natively available even if you use the latest firmware version.

In this case, it is advisable to move to the successor CS141.

Model overview

Device	Function	Remarks
EQUALINKKIT_B4	Battery management	External Webmanager
EQUALINKKIT_BSC4	Battery management	Slot adapter

Device	Function	Remarks
CS141L	SNMP adapter	external adapter
CS141SC	SNMP adapter	Slot Adapter for UPS with slot
CS141LM	SNMP adapter	External adapter with MODBUS output (RS485)
CS141SCM	SNMP adapter	Slot adapter with MODBUS output (RS485)
CS141BL	SNMP adapter	External adapter BUDGET-Modell (No COM2- and AUX-port)
CS141BSC	SNMP adapter	Slot adapter BUDGET-Modell (No COM2- und AUX-port)
CS141R_2	SNMP adapter	Slot adapter for PILLER/CTA/RIELLO/AROS UPS Italy
CS141MINI	SNMP adapter	Slot adapter for UPS models with MINI Slot

Additional devices based on CS141:

Device	Features	Supported UPS devices
CS141L	Additional Mini DIN 8 COM Port for RS232. AUX Port for Digital Input/Output. Remote RAS Management optional.	Over 1400 UPS models from over 80 different manufacturers are supported
CS141SC	Additional Mini DIN 8 COM Port for RS232. AUX Port for Digital Input/ Output. Remote RAS Management optional.	All devices with basic slot SC
CS141LM	Additional Mini device. AUX Port for Digital Input/ Output. Remote RAS Management optional.	Over 1400 UPS models from over 80 different manufacturers are supported
CS141SCM	Additional RS485. AUX Port for Digital Input/ Output. Remote RAS Management optional.	All devices with basic Slot SC
CS141BL	Slot Budget variant of the CS141. UPS Management via LAN. No AUX Port for floating contacts. No COM2 Port for Pipe-through, sensors, etc.	Over 1400 UPS models from over 80 different manufacturers are supported
CS141BSC	Slot Budget variant of the CS141. UPS Management via LAN. No AUX Port for floating contacts. No COM2 Port for Pipe-through, sensors, etc.	All devices with basic Slot SC
CS141R_2	Additional Mini DIN 8 COM Port for RS232.	Riello and Aros UPS with Netman Slot
CS141MINI	Additional Mini DIN 8 COM Port for RS232.	UPS devices with MINI Slot (Soltec, Voltronic, etc.)

All CS141s can manage UPS systems providing a native serial protocol. Furthermore, the CS141 can be easily integrated into existing SNMP systems. All models of the CS141 family provide an own unique web server with configurable event management for automating job executions based on the status of the UPS.

All models of the CS141 family provide an own unique web server with configurable event management for automating job executions based on the status of the UPS, including:

- email notification
- Full RCCMD functionality
- shutdown commands,
- logfile entries, shutdown of the UPS, - graphical log files,
- shutdown and wake-up -commands (WOL)

In addition, the CS141 can also be individually configured using a scheduler to trigger job executions for many events, e.g.:

- battery testing
- calibration
- UPS or system shutdown / restore.

The CS141 provides a wide range of network management features to inform and alert required persons before a critical incident occurs. The CS141 can even monitor other SNMP devices and thanks to its built in RCCMD solution, combine them to an intelligent power resource management.

Each adapter has 2 years warranty as well as free updates for 3 years.

All devices are manufactured in Germany

Content on delivery

The scope of delivery of a CS141 includes a supplementary Software Compact Disk and additional hardware.

**Note:**  
The budget edition does not support all features described in this manual.

Product	Included on delivery				
	External power supply	User's manual on CD	Mini-DIN-8 Connector (MODBUS)	RS-485 Via COM2	Rescue Jumper
CS141L	X	X	X		X
CS141SC		X	X		X
CS141LM	X	X		X	X
CS141SCM		X		X	X
CS141BL	X	X			X
CS141BSC		X			X
CS141R_2		X	X		
CS141MINI		X	X		

Function overview CS141

In SNMP mode, the CS141 adapter works with a preinstalled Simple Network Management Protocol (SNMP) software agent.

This agent exchanges status data with the UPS via so-called "get / set" commands and forwards them in the form of "trap messages" to predetermined recipients. These "trap messages" allow to alert necessary persons during or before critical situations happen within the UPS. Typical information can be switching to battery power or the end of a power failure.

*In addition, the SNMP adapter can send RCCMD signals (Remote Control Commands):*

On clients with the RCCMD software installed, freely configurable functions can be triggered – the functionality range allow nearly everything.

Administrators can run a simple system shutdown as well as a highly complex shutdown and restart routine. In addition, the web interface is also a control of the UPS possible.

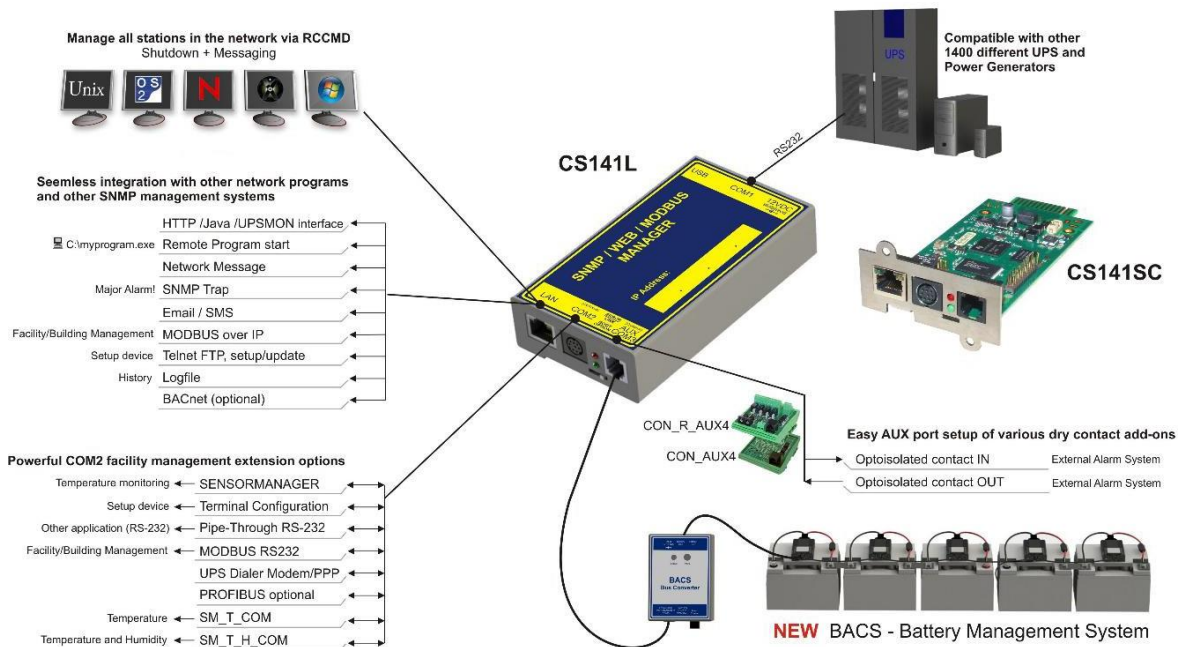

In SNMP mode, the CS141 adapter works with a preinstalled Simple Network Management Protocol (SNMP) software agent.

This agent exchanges status data with the UPS via so-called "get / set" commands and forwards them in the form of "trap messages" to predetermined recipients. These "trap messages" allow to alert necessary persons during or before critical situations happen within the UPS. Typical information can be switching to battery power or the end of a power failure.

In addition, the SNMP adapter can send RCCMD signals (Remote Control Commands): On clients with the RCCMD software installed, freely configurable functions can be triggered up to complex shutdown and start routines

In addition, administrators can monitor and control their UPS possible by using the build in web interface to ensure an all-in-one solution for nearly the entire UPS system:

### *SNMP Trap functionality*

The basic task of the adapter is to communicate alarm states of the UPS to an according monitoring station (traps) or to provide UPS data if monitoring stations poll. With this function, e.g. the power supply and battery status of a UPS are monitored by an SNMP management station.

Additionally, the CS141 provides functions for simulating and testing trap messages during configuration procedure.

### *Remote Control:*

Due to the fact the CS141 is capable to configure it is possible to trigger different remote-controlled actions. Administrators can perform battery tests, bypass the UPS batteries or configure UPS behavior

#### **Note:**

Depending on the UPS you are using, provided functions may differ.

### *Compatibility according to third party network management systems*

The SNMP adapter is compatible with all common network management systems. All SNMP systems providing the compilation of a MIB - or already contain the Management Information Base (MIB) / Request for Comment 1628 (RFC) for UPS systems - can be operated with CS141.

### *Full RCCMD support:*

Due to the fact the CS141 is a full manager and not just an SNMP-Card to collect and provide data, the entire network shutdown routine can be configured to react as fast as possible:

Thanks to integrated RCCMD support, the CS141 offers a flexible and fast way to operate even the most complex shutdown solutions. By the usage of standardized network technologies and protocols, the RCCMD server transfers control commands that are executed by the clients in real time.

### *RS-232 / pipe-through:*

In some cases, different networks without any connections have to be configured to use the same UPS. With the new pipe-through capability administrators can connect two CS141 and let the communication of the UPS work with both devices:

By doing so, two different CS141 can communicate to according networks without additional hardware.

### *RS232 UPS interface:*

The CS141 provides a standard RS232 interface to allow establishing a serial connection to any UPS providing this standard.

#### **Note:**

Please use only the original UPS communication cable supplied with the UPS. In case of using a contact UPS, choose the special designed cable of the manufacture. If you have any questions regarding special connection cables, refer your UPS dealer.

### *Provided real-time logfiles:*

The CS141 provides a proven compilation of logfiles to reconstruct a complete timeline in case of critical incidents. This logfile is accessible via UNMS, UPSMAN, WebGUI and FTP or can be send via mail to configured mail-accounts.

### *Advanced mailing capabilities*

Each model of the CS141 family provides the capability to connect to any mail server using standardized encryption technologies.

### *Unique web server included:*

The unique build-in Web server of the CS141 displays all information about the device itself, connected sensor and external hardware. The software module UPSView inside the CS141 can also be used to display a graphical representation of these data.

To Access the web interface administrators and technicians may just use common browsers (Edge, Firefox, Chrome, Safari etc.).

### *Networking*

Modern UPS solutions are much more than just batteries. The CS141 takes an eye on this fact and co-operates with the UPS:

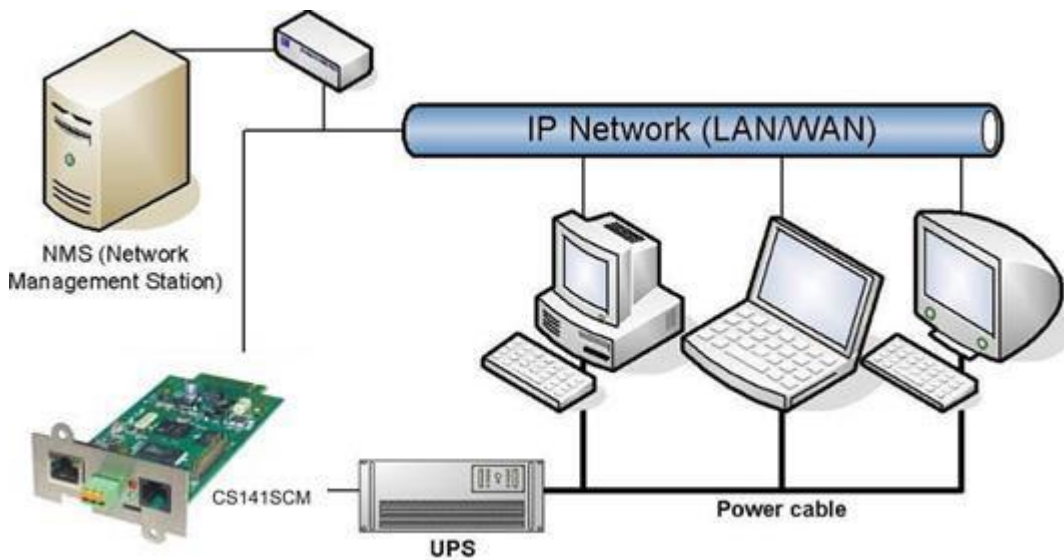

The UPS ensure power to all clients and the CS141 manages the solution to inform and finally to shut down all clients before batteries are depleted.

#### MODBUS:

Modbus is the standard protocol used in industrial applications for monitoring and building management. All devices of the CS141 family therefore provide as standard a MODBUS over IP interface. In addition, CS141 with COM2 connector provide MODBUS over RS232 (CS141L & SC) and Modbus over RS485 (CS141L, SCM).

#### SNMP:

All models of the CS141 family communicate using SNMP via the UPS standard MIB RFC 1628. If a system does not include this standardized MIB, administrators can download the RFC1628 data file from [www.ExponentialPower.de](http://www.ExponentialPower.de) to compile the MIB at a later time.

Once you have compiled the MIB file into the appropriate MIB directories of your SNMP station, the CS141 can be used.

#### UPSTCP:

CS141 provides with UPSTCP a complete API interface to ensure optimal integration into existing networks. Upon request, this interface specification can be supplied to manufacturers of software in order to enable their own integration.

### Network integration of the CS141

All models of the CS141 family are configured exclusively through the specially designed web interface. In order to facilitate the initial configuration or a quick on-site intervention, the CS141 family Web Manager is preset to the hard-coded IP address 10.10.10.10:

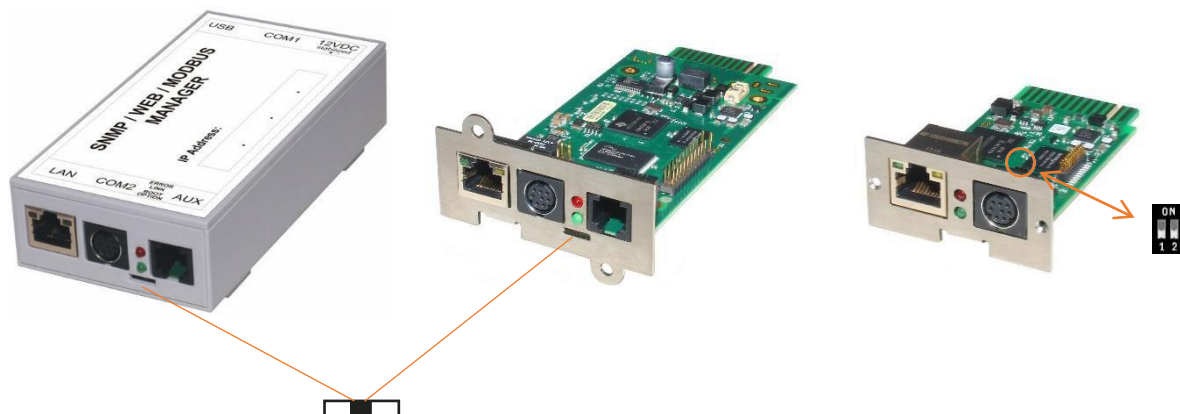





In factory default setting, the sliding switch is in the center position and the CS141 is in configuration mode. Due to its more compact design, the CS141 MINI breaks the standard and uses on-board dip switches instead of a sliding switch:

Both dip-switches set to off position activates the configuration mode.

In this mode, some functions such as IP address data are configurable, but available only as soon as CS141 is switched to regular operating mode.

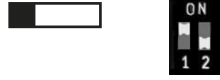
The following table lists regular operating modes: (UPS CARD MODELS ONLY)

<p><b>Sliding switch center position / DIP 1 + 2 OFF:</b></p>	
<p>Enables configuration mode. After reboot the hard-coded IP address 10.10.10.10 is active.</p>	
<p><b>Sliding switch to the right / Dip 1 OFF + 2 DIP 2 ON:</b></p>	
<p>Automatic IP addressing: DHCP is activated and an IP address is set automatically. Check the MAC address of your CS141 to identify the IP address in the DHCP server table.</p>	
<p><b>Sliding switch to the left / DIP 1 ON + DIP 2 OFF:</b></p>	
<p>Use of the IP address values manually configured. If DHCP is used, the IP address needs to be blocked for single usage.</p>	
<p><b>CS141 Mini special feature:</b></p>	
<p><b>Both Dip-Switches ON:</b></p>	
<p>Enables the rescue-mode for advanced system maintenance operation.</p>	

**Initial configuration 10.10.10.10**

Preparation at the CS41

Prior to commissioning, ensure the slide switch on the front is set to center position. In case of CS141Mini, both Dip switches of the CS141 MINI has to be set in OFF position. After start up, the CS141 can be runs in configuration mode, available at IP address 10.10.10.10.

**Note:**

Changing the mode via the hardware switches requires a reboot of the CS141. You can perform the restart in two ways:

- By removing the power supply (hardware reset)
- Using the Restart feature to be found inside the Tools menu (Software Reset)

This operation does not apply the UPS the CS141 is connected to - the functionality will be kept up independently to the CS141.

Preparing the Workstation

After starting, the CS141 Web Manager can be found using the following network address:

IP address 10.10.10.10  
Subnet Mask: 255.255.255.0

Depending on the type of connection you choose, the service computer can be connected directly to a crossover cable or via the local network segment.

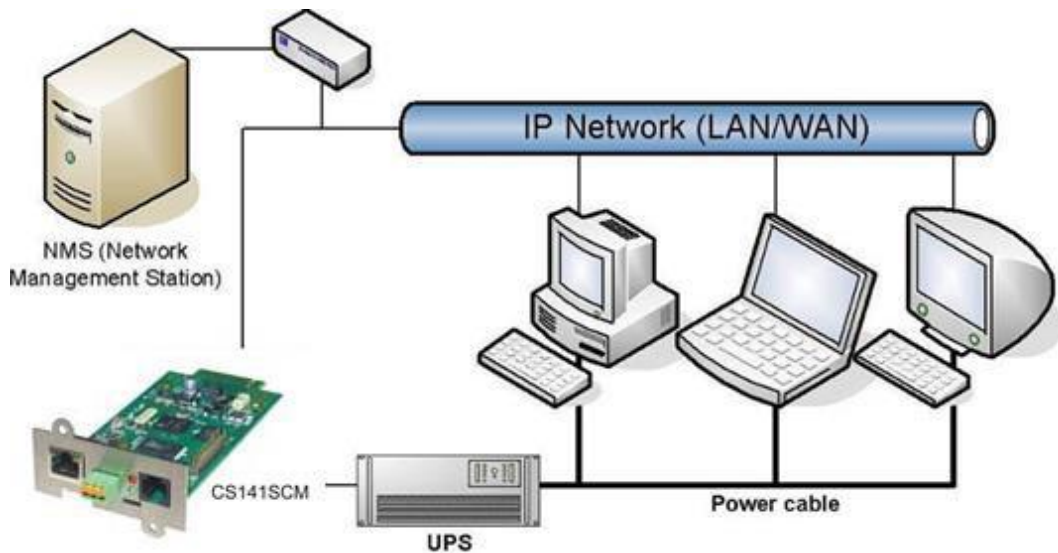



This is recommended network settings for the client PC:

IP address 10.10.10.11  
subnet mask of 255.255.255.0  
Gateway 10.10.10.11  
DNS: none

Obey whether the settings of your service computer work by opening a console in order to enter the command

```
C:\Users\Gunnar>ping 10.10.10.10

Ping wird ausgeführt für 10.10.10.10 mit 32 Bytes Daten:
Antwort von 10.10.10.10: Bytes=32 Zeit<1ms TTL=64
Antwort von 10.10.10.10: Bytes=32 Zeit<1ms TTL=64
Antwort von 10.10.10.10: Bytes=32 Zeit<1ms TTL=64
Antwort von 10.10.10.10: Bytes=32 Zeit<1ms TTL=64

Ping-Statistik für 10.10.10.10:
    Pakete: Gesendet = 4, Empfangen = 4, Verloren = 0
    (<0% Verlust),
    Ca. Zeitangaben in Millisek.:
    Minimum = 0ms, Maximum = 0ms, Mittelwert = 0ms

C:\Users\Gunnar>
```

PING 10.10.10.10.

If the settings are correct, the CS141 will respond accordingly. As soon as the CS141 answers correctly, open a web browser. The CS141 web interface will be accessible by typing `http://10.10.10.10`

#### Adding a route

Within larger installations with well-defined domain services, it may be helpful temporarily editing the routing table.

In case of using a route, ensure the CS141 is located within the same network segment and is therefore directly accessible

*Example: Adding a route into a Windows-driven Computer:*

1. Run the command console `cmd` as *administrator*  
This is important due to the fact, Windows requires a user with local administration rights to add a route.
2. Enter the following command: `route add 10.10.10.10 <IP address of your system>`  
Windows will accept the command and return `OK`

```
C:\Windows\system32>route add 10.10.10.10 192.168.200.17
OK!
```

In order to check the new route, enter the command `route print`

```
IPv4-Routentabelle
=====
Aktive Routen:
    Netzwerkziel    Netzwerkmaske    Gateway    Schnittstelle    Metrik
    0.0.0.0          0.0.0.0          192.168.200.1  192.168.200.17    20
    10.10.10.10     255.255.255.255  Auf Verbindung  192.168.200.17    21
    127.0.0.0       255.0.0.0       Auf Verbindung  127.0.0.1         306
    127.0.0.1       255.255.255.255  Auf Verbindung  127.0.0.1         306
    127.255.255.255 255.255.255.255  Auf Verbindung  127.0.0.1         306
    192.168.200.0   255.255.255.0   Auf Verbindung  192.168.200.17    276
```

Under active routes, 10.10.10.10 should be seen. As an additional test, use the command `ping 10.10.10.10` to verify the CS141 web manager is responding as expected.

**Note:**

In configuration mode, only one CS141 with the default IP address of 10.10.10.10 can be operated. If you connect several devices at the same time this way, a network conflict is unavoidable.

Using the DHCP Option

The DHCP mode

Since the models of the CS141 family can fulfill many functions due to their flexibility, it is a very realistic scenario that you need to commission several devices at the same time within an installation procedure - Unfortunately there is no fixed IP address that can be assigned for the moment.

To avoid a network conflict, activate the DHCP mode for automatic IP address assigning:

Slide the slide switch to the right, i.e. to the outer edge of the CS141. For the CS141 Mini, set dip switch 1 to OFF and move dip switch 2 to ON. Next reboot, the web manager will boot in DHCP mode according to the hardware configuration and obtain an IP address from your network.

Required information for finding CS141 in DHCP-Mode

To identify the devices, please note the MAC address including location data before proceeding hardware installation. The MAC address can be found on any CS141 web manager as a unique sticker:

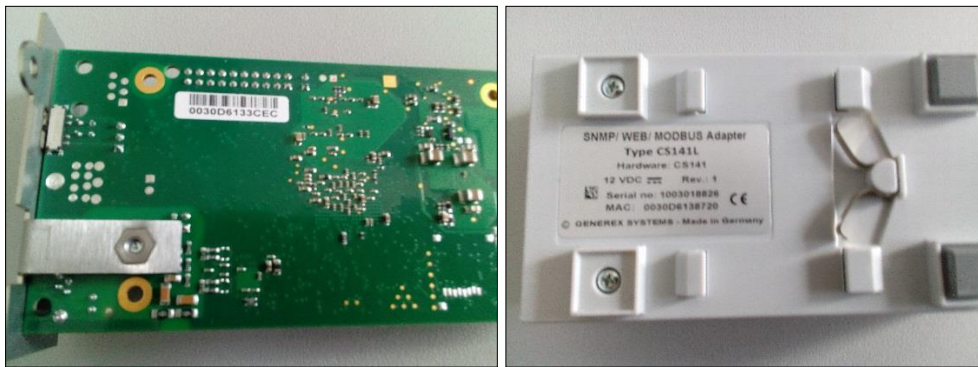

Ensure a suitable DHCP server is available for this operating mode, otherwise the card will not be able to get valid IP address data automatically.

CS141 MINI and CS141 / R2

Due to the compact design, the lable sticker of CS141 MINI and the CS141 / R2 differ and shows only the last three octets of the MAC address.

The MAC address of a EXPONENTIAL POWER- network interface starts with these address values:

**00-30-d6-xx-xx-xx**

The last thre values can be found at the lable sticker on the back of the CS141 MINI or CS141 R2:

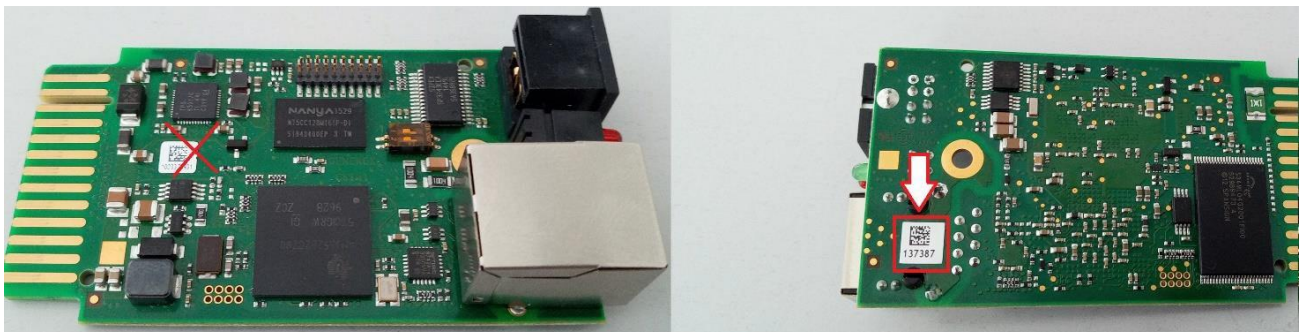

A common bar code scanner that can handle QR codes or a smartphone with a QR- Code app will display the complete MAC address.

## Note

Please notice that you use the sticker on the back. This will show the last three octets of the MAC address. When on installation site, you can simply figure out the MAC address:



In this case, the MAC address is 00-30-d6-13-73-78

## Netfinder: Search for IP-addresses used with CS141 devices

The Netfinder is a software tool that can display all CS121 and CS141 devices that can be reached inside a specific network segment. It is available at the local support CD and at [www.Exponential Power.de](http://www.Exponential Power.de).

To perform a quick search for valid IP addresses, use the tool Netfinder.

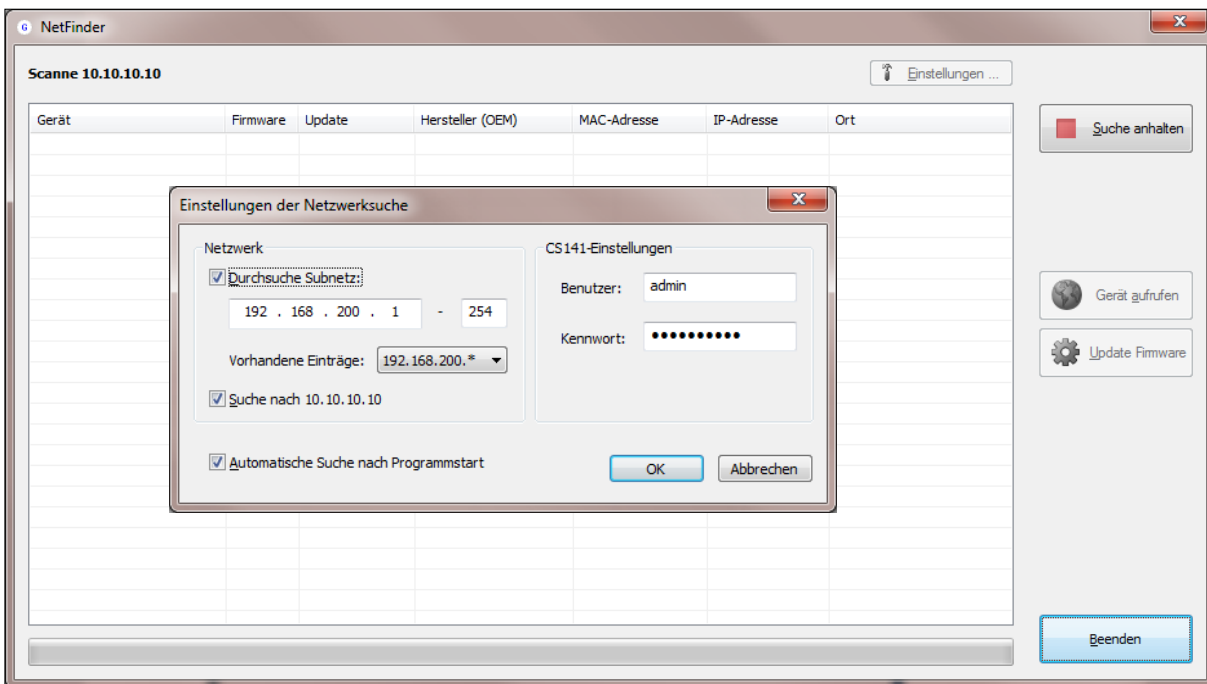

The default search generally refers to the network segment the service computer resides. To scan other networks and subnets for CS121 or CS141 installations, it is necessary to specify the appropriate IP address ranges.

Gerät	Firmware	Update	Hersteller (OEM)	MAC-Adresse	IP-Adresse	Ort
CS141L	1.61	Nicht nötig	ABB (36)	00-30-d6-16-1d-e7	192.168.222.106	
CS141BSC	1.60	Nicht nötig	Online (4)	00-30-d6-13-3d-eb	192.168.222.104	
CS141R_2	1.60	Nicht nötig	Piller (3)	00-30-d6-12-6e-c7	192.168.222.107	
CS141L	1.56	Verfügbar (1.58)	ABB (36)	00-30-d6-12-60-70	192.168.222.108	
CS141LM	1.60	Nicht nötig	AMG Accent Monitorin...	00-30-d6-12-0f-2b	192.168.222.110	
CS141SC	1.60	Nicht nötig	Salicru (82)	00-30-d6-16-bb-f3	192.168.222.112	
BACSKIT_B4	1.60	Nicht nötig	Generex (12)	00-30-d6-12-60-61	192.168.222.114	
BACS II Webmanager BUDGET	5.62	Nicht nötig	UPS LTD (84)	00-03-05-18-77-6A	192.168.222.113	
BACS II Webmanager BUDGET	5.62	Nicht nötig	Hoppecke (91)	00-03-05-18-59-7A	192.168.222.103	
CS131 16MB	5.62	Nicht nötig	ALTERVAC (92)	00-03-05-18-6A-A4	192.168.222.111	GENEREX Hamburg Garage
CS141BSC	1.60	Nicht nötig	CET (81)	00-30-d6-12-6f-9d	192.168.222.119	
CS131 16MB	5.34	Verfügbar (5.62)	Generex (12)	00-03-05-18-96-A2	192.168.222.123	

The EXPONENTIAL POWER Netfinder software provides a detailed overview of all devices in the network and allows quick and easy access to the web console of the respective manager.

**Note:**

In DHCP mode, IP addresses may change sporadically depending on the network configuration. Therefore, several Webmanager monitored by a parent system such as UNMS II should receive a fixed IP address.

In any other case, technicians can easily detect and access installed devices by using Netfinder.

**Configuring the CS141 device***Differences between configuration mode, rescue mode and operation mode*

Each model of the CS141 family will be configured exclusively by an intuitive web interface. Independently to this common ground, the web managers offer four valid operating states, which fundamentally differ from each other.

**1. The configuration mode**

The configuration mode is the default preset on delivery:



The slide switch is in center position and the dip switches of the CS141Mini are both set to OFF. The web manager can be reached via hardware-coded preset IP address 10.10.10.10 and allows all system-relevant settings. Since the CS141 generally uses the preset IP address in configuration mode, this mode allows importing backup data and to be adjusted after restart without harming the network.

**2. Operating mode**

Depending on the setting, the sliding switch will be set to left or right position. In case of CS141Mini, Dip switch 1 or 2 is switched on

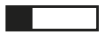

The CS141 can be run in two different operation modes:

In manual mode, enter the IP address information. Please note that incorrect settings may cause address conflicts on the network or the settings made may not work. The data required for manual mode can be obtained from local system administrators.

**Note:**

In manual mode, the data is entered by technicians and thus permanently assigned. The CS141 will use this data to make itself known in the network. Assigning an address twice will cause a network conflict. In this case, switching back to configuration mode at any time is possible to reach the Web Manager at the default IP address 10.10.10.10.

In DHCP mode, the CS141 automatically inherits settings assigned by a server and uses them for the IP address settings. The web server takes over the administration of the IP address data. After the startup process, the web manager can be found using the tool Netfinder.

**Tipp:**

As a rule, DHCP-assigned IP addresses via automatic mode are reserved for specific time. DHCP clients therefore ask after 50% of this time window whether the IP address is still valid or will be assigned to another client. How statically the DHCP server allocates IP addresses is a decision the system administrators make.

Due to this fact another IP address can be re-assigned after booting or a CS141 seems to be lost during regular operation.

When selecting the operating mode, the function of the CS141 within the network should be considered:

If the Web Manager runs as an active element within shutdown solutions or in conjunction with higher-level monitoring structures, a manually assigned IP address makes sense, since an authenticated and fixed IP address must be configured.

As another advantage the CS141 starts faster with preconfigured IP addresses if the DHCP server is not available.

**3. The rescue mode**

In this mode, an additional jumper is set and the slide switch center position.

The Webmanager can access two ROMs for booting. Therefore, this failsafe design is able to contain the current firmware as well as the last state before the firmware update including the configuration file.

When the web manager is set to rescue mode, the logic starts from the last known state and is initially fully operational again but indicates in the general system information that the web manager is in rescue mode. The rescue mode represents a manually chosen emergency operation state and is intended to repeat a faulty flash process.

**Before you start**

Installation examples

The CS141 was designed to provide a maximum of flexibility and freedom during the installation - as a result the CS141 match the tasks of modern UPS systems as well as expectations coming with it.

Case one:

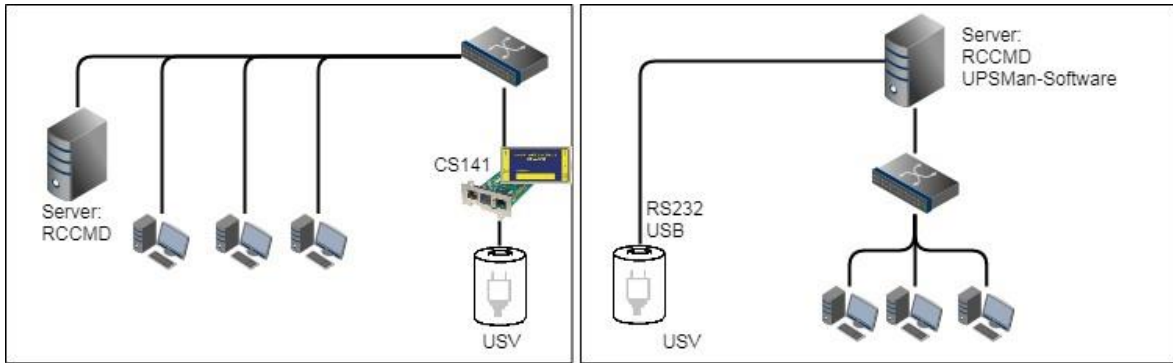

The central role of the UPS is to ensure emergency power until the server shut down securely during main power loss. The complete shutdown routine is controlled by the CS141, as this is a full-fledged manager that can act independently. As an alternative to the CS141, the shutdown routine can also be initiated via the UPSMan software. Further servers need only one more RCCMD license.

*Two separate networks*

It becomes more difficult as soon as emergency power coming one UPS has to ensure the shutdown of two servers inside separate networks without linking possibilities:

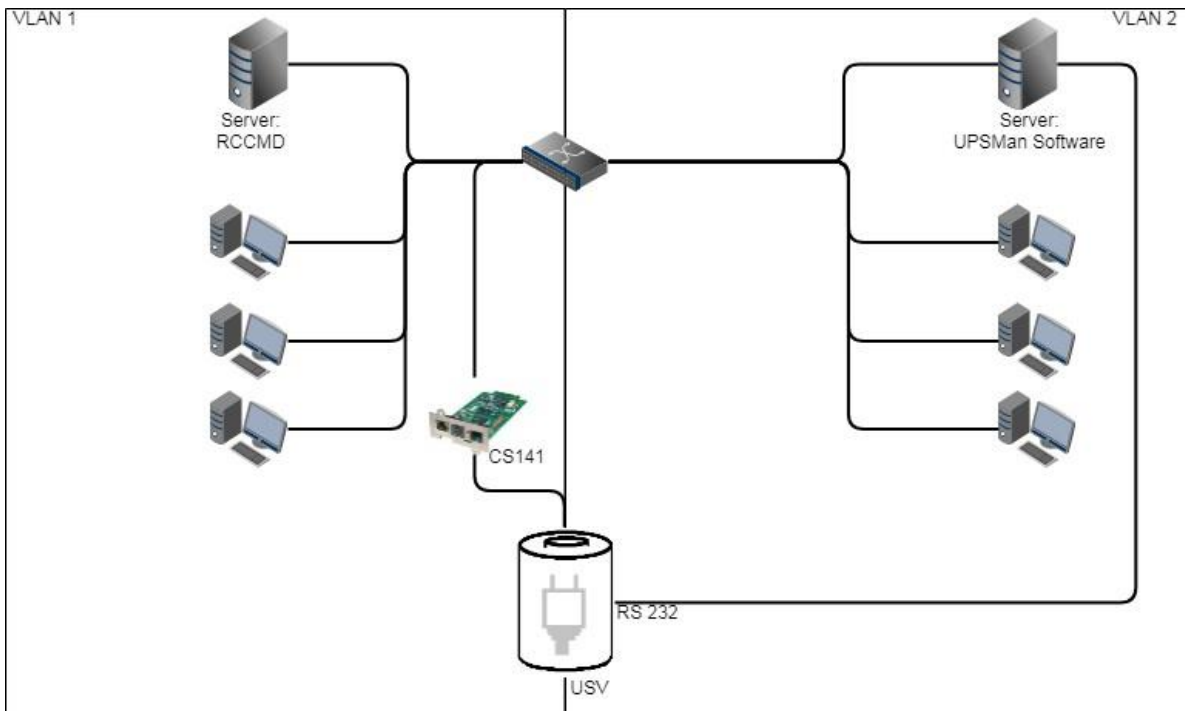

In this case, the UPS becomes a central role inside the network's emergency power security.

Since the VLANs represent physically separated own network segments, only one server can be secured by the CS141. The UPSMan software will secure the second server:

Once Installed directly on the server, it communicates with the UPS via the COM port of the server and offers the same functionality as the CS141 including a full support of RCCMD. Therefore VLAN 2 represents a "software only" solution that does not require a CS141 as additional hardware.

The required RS232 connection is not available or the installation of software is not possible?  
Just use servers providing 2 network cards:

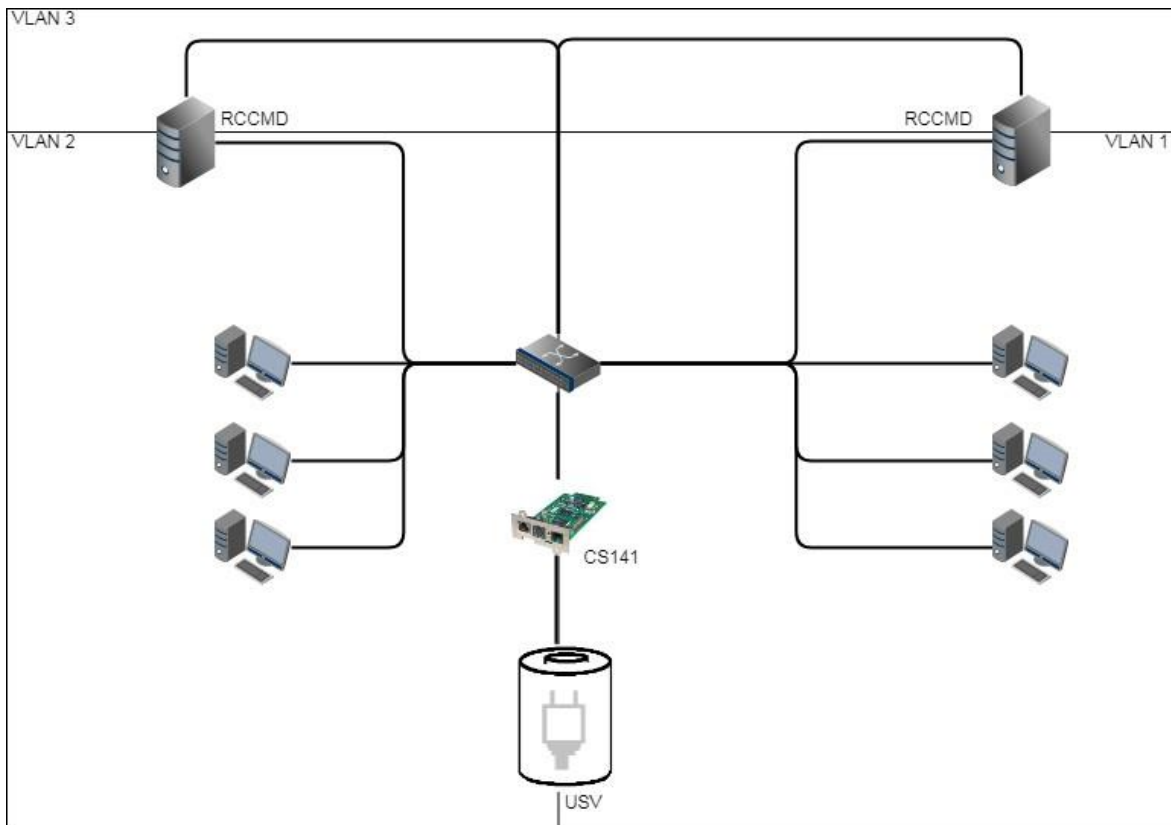

If you have chosen a solution with two network cards and the UPS provides a usable RS232 interface, this solution allows future installations - even complete closed up networks are possible.

#### Pipe Through

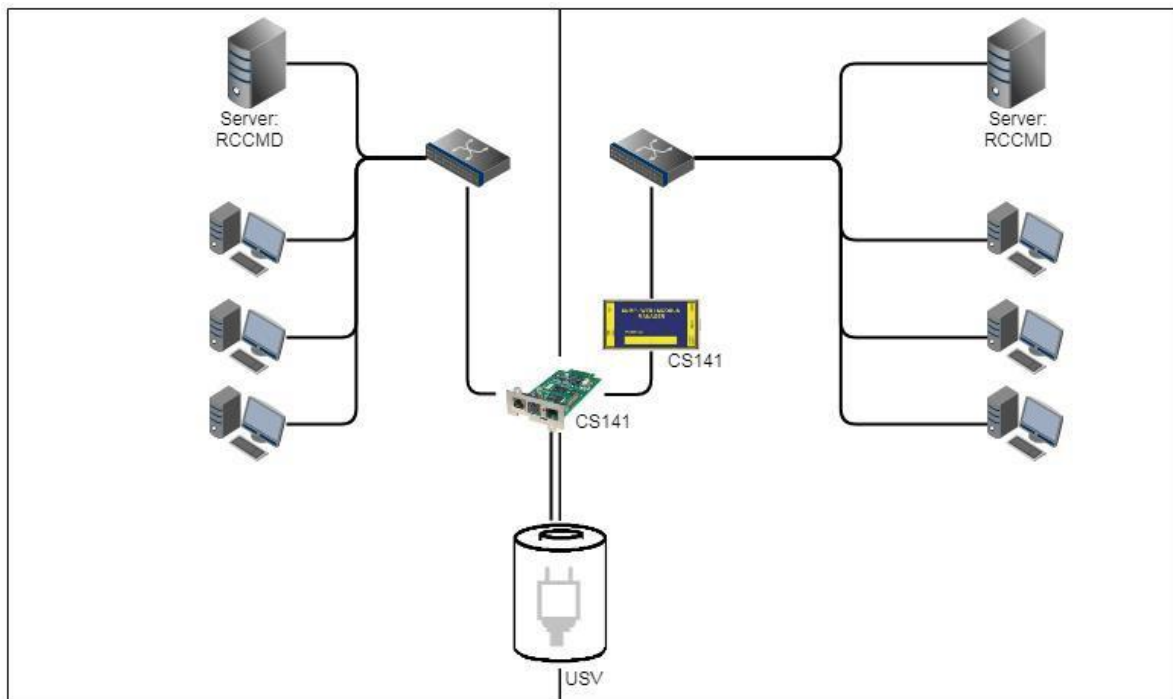

In some companies, physical separation of the networks is essential, but the UPS does not offer the option of operating RS232 and slot parallelly. In this case, the signal can be looped by the pipe-through function: This feature allows two CS141 jointly perform the same function inside of complete separated networks. Furthermore, different CS141 versions can be combined as desired - Even the combination CS141 / UPSMan software is possible for a maximum of flexibility.

#### Complex structures

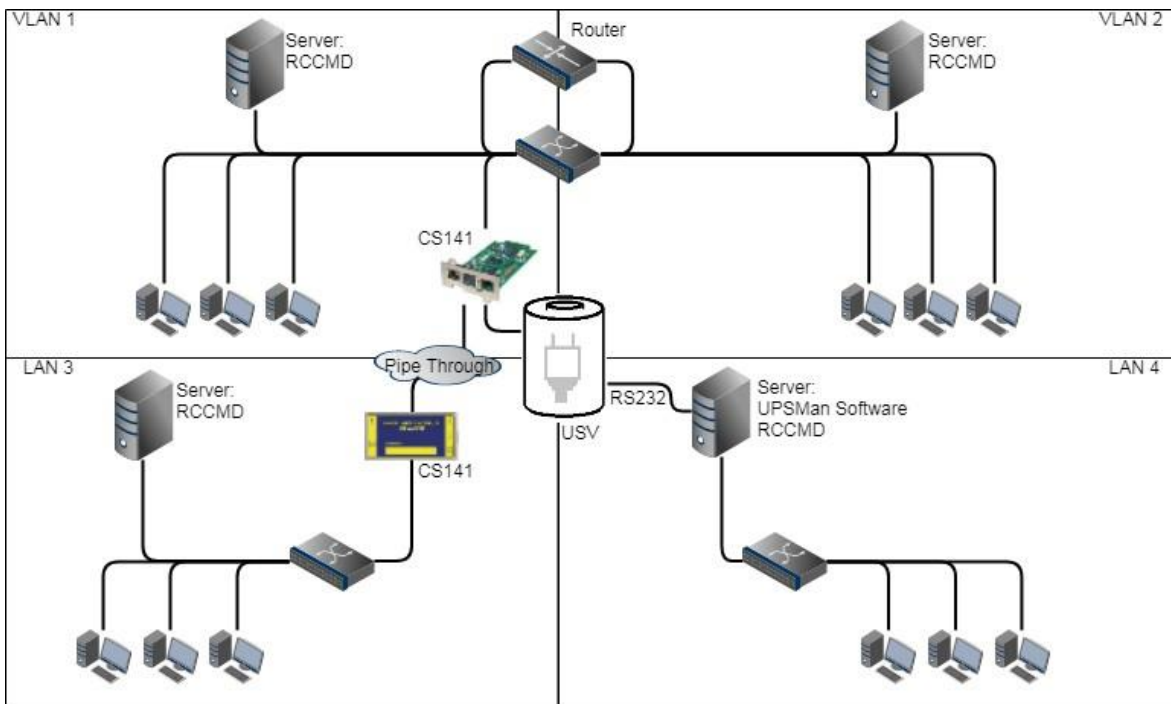

In this example, VLAN 1 and VLAN 2 were logically linked by a router to allow one CS141 sending RCCMD commands to all servers inside of VLAN 1 and VLAN2. At the same time, the Pipe Through function allows the same signal coming from the UPS to a third CS141 physically installed inside LAN3. Due to this fact, the CS141 can completely control LAN3 and ensure a shutdown routine using RCCMD. LAN 4 is connected to the UPSMan software via the RS232 interface and the server itself can act like a CS141 including full RCCMD functionality. This example demonstrates a complex system:

- two complete separated networks
- two logical linked networks
- on central UPS solution to provide auxiliary power in case of main power is down.

Each CS141 or UPSMan is completely informed about the current UPS alarm state. Furthermore, each network can be managed for its own without harming others.

**Note.**

The UPSMAN software also handles communication via USB - If your UPS supports parallel operation, it is possible to combine USB, Slot and RS232.

Required Ports

For optimal functionality, the CS141 requires a various number of ports open or available. Some ports are standard ports within your computer, others need to be opened in order to use all functions. Please check on-site whether the following ports are available for usage:

Echo	7/tcp
echo	7/udp
WOL	9/udp
ftp-data	20/tcp
ftp	21/tcp
telnet	23/tcp
smtp	25/tcp
http	80/tcp
snmp	161/udp
snmptrap	162/udp
time (rfc868)	37/tcp
time (sntp)	123/tcp
rccmd	6003
Upsmon	5769
Modbus over IP	502/tcp

Please note that the CS141 can also provide special functions like remote syslog or BACnet over IP.

With some functions, the port assignment is dynamic and, depending on the network, must be managed or specified by a local network administrator. If you need additional ports for your configuration, it will be mentioned exclusively in the configuration step. In this case, please refer your responsible network administrator.

## Note

This user guide covers all the menus that you can encounter when configuring a CS141. Basically, it is written for firmware version 1.62 and subsequent versions with a special eye on SITEMANAGER 6 and SITEMONITOR 6. Many menus will be available for all products of the CS141 family and the configuration method is similar. Once you understood the concept, you will be able to configure any device of the CS141 family intuitively.

If you cannot find a menu, there are several reasons:

- The CS141 you are using does not offer this feature
- The firmware version you are using is older so the feature this manual describes is not available
- The configuration menu is present, but has been delayed by the ongoing development process

## Basic settings and passwords

After you enter the IP address, the CS141 responds with its web interface and prompts for a password.

There are three users with different system rights to choose from. The users are predefined, the passwords can be freely defined:

User: admin	Password: cs141-snmp	... System administrator, complete menu tree accessible
User: engineer	Password: engineer	... Technician, administrative restricted system access
User: guest	Password: guest	... guest account, only status indicators visible

To start initial configuration, log in with user admin and default password cs141-snmp

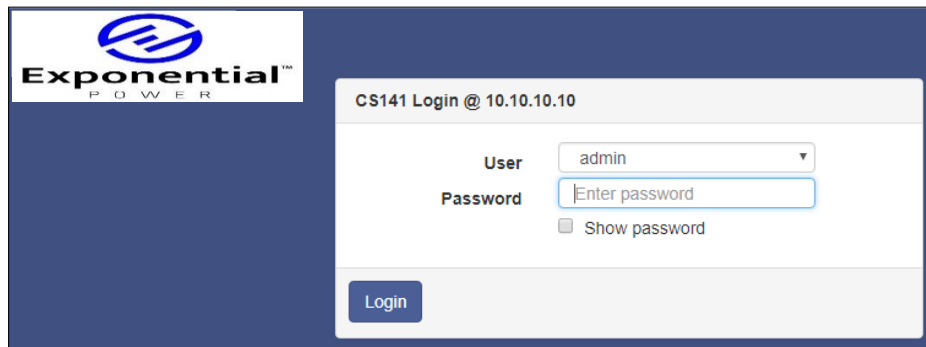

## Note:

Modern web browsers are designed to display websites as fast as possible. Among other things, special techniques are used to pre-load images, pages and query masks are loaded into a buffer for a faster review. In some cases, this web browser behavior may result in screen errors.

If these phenomena occur, update the browser by pressing CTRL + F5 or clear the cache of the web browser and deactivate additionally installed tools and addons, which could obstruct the presentation.



























## CS141 configuration menu overview

This is the CS141 menu tree without expansion modules.

If you connect additional modules in order to extend functionality, corresponding menus are automatically displayed after installing and activating the functions.

This menu tree shows all basic functions each CS141 model provides:

 UPS Monitor	→ UPS Monitoring Screen
— Devices	→ <b>System Tab: Devices</b>
 Setup	→ Basic setup of COM ports and connected devices
— UPS	→ <i>Sub menu: UPS setup</i>
 Setup	→ Select the UPS model
 Events	→ Configure Jobs for the UPS events
 Functions	→ Advanced UPS functions
 Custom Thresholds	→ Enable / Disable some custom thresholds for UPS events
— Services	→ <b>System Tab Services</b>
 Setup	→ Enable / disable services available for CS141
 Email	→ Configure email settings for mailing jobs
 Email-Traps	→ Configure mail trap settings for UNMS II
 SNMP Agent	→ Configure the SNMP agent for SNMP v2/v3
 Modbus	→ Configure the Modbus agent
 BACnet	→ Configure the BACnet agent for BACnet over IP queries
 RCCMD	→ Configure encryption and access modes for RCCMD
 Webserver	→ Basic http / https setup and ports, upload SSL certificates
 Rsyslog	→ Configure Syslog Server uplink
— System	→ <b>System Tab: System</b>
 About	→ Basic CS141 information window, IP, MAC, firmware, etc.
 General	→ Configure System language, responsible staff, etc.
 Network	→ Configure network settings, IP, gateway, DNS, etc.
 Date & Time	→ Configure NTP services, local system time, time zone
 Scheduler	→ Run scheduled jobs independently to system events
 Users	→ User management control, enable / disable users and set passwords
 Tools	→ Toolbox for advanced system diagnostics, delete log files
 Wizard	→ Setup Wizard for initial configuration
 Backup	→ Configuration backup / restore dialog
 Update	→ Perform Updates via drag'n'drop
— Logfile	→ <b>System Tab: Logfile</b>
 EventLog	→ CS141 event log files
— UPS	→ <i>Sub menu: UPS logfile</i>
 DataLog	→ UPS data log
 DataLog Chart	→ Graphical view of UPS data log
↳ Logout admin	→ Log out and proceed to login screen
Automatic Logout in 15 min	

*Extended menu trees*

Depending on the CS141 model and available additional modules, additional menus are available. Please note that not every model can provide the following menus:

*Sensor menus*

*Depending on the type of sensor, the following menus will be added automatically:*

1. *Standalone sensor on COM 2*

After selecting sensor at COM 2 Sensor and as sensor type SM / T or the combination sensor SM / TH, following menus will appear automatically:



→ Sensor monitoring screen

→ **System Tab: Devices**

→ *Sub menu: Sensors*

- Configure measuring range, alarm marker, operating range
- Configure jobs to the alarm marker

2. *SENSORMAN2 at COM 2*

*After selecting sensor at COM 2 Sensor and as sensor type SENSORMAN2, following menus will appear automatically:*



→ Sensor monitoring screen: All sensor data in real time

→ **System Tab: Devices**

→ *Sub menu: Sensors*

- Configure up to 8 sensors, digital inputs and outputs
- Combine different sensor events to combined alarm marker
- Define Jobs to single sensor events or combined alarm marker

With the sensor matrix, an additional function is available that allows to combine single sensor events to collective events.

3. *CON\_AUX4 / CON\_R\_AUX4 selected at COM 3*

The following menus are added when you connect a CON\_AUX4 or a CON\_R\_AUX4 relay card to the COM 3 port of the CS141



The screenshot shows the Exponential Power software interface. The 'AUX Monitor' option is selected in the main menu. The 'Devices' sub-menu is expanded, showing 'Setup' and 'AUX' options. The 'AUX' sub-menu is further expanded, showing 'Setup' and 'Events' options.

- AUX monitoring screen
- **System Tab: Devices**
- *Sub menu: AUX*
  - Relay Card basic setup
  - Event handling configuration dialog CON\_AUX4 or CON\_R\_AUX4

4. *BUZZER selected at COM 3*

The CS141 provides an additional buzzer for advanced acoustical alarm notifications. The following menus will appear when you choose the Buzzer at COM 3 of the CS141:



The screenshot shows the Exponential Power software interface. The 'Buzzer Monitor' option is selected in the main menu. The 'Devices' sub-menu is expanded, showing 'Setup' and 'Buzzer' options. The 'Buzzer' sub-menu is further expanded, showing 'Setup' and 'Events' options.

- Buzzer monitoring screen
- **System Tab: Devices**
- *Sub menu: Buzzer*
  - General buzzer setup, frequency, on / off, etc.
  - Buzzer event handling: Jobs to do because a Buzzer is active

6. *EQUALINK selected at COM 3*

EQUALINK - the "Battery Analysis & Care System" - is the most advanced system on the market to manage stationary battery systems. It is a standalone battery monitoring and management system that can be easily integrated into your network infrastructure.

With its intelligent web-technology configurable management technology, it cyclically checks the internal resistance, the temperature and the voltage of each individual battery. In addition, it can readjust the charge voltage of each battery and manage environmental readings (temperature, humidity, hydrogen gas content) as well as loads (UPS, inverters, and other devices). The Batteries are thus always kept in the optimal working range.

**Note:**

Since the configuration of the system is independent to the rest of the functions, BACS functions are listed separated at Part II of this manual.

For more information and a detailed table of content about BACS, please refer to page 6 of this user guide.

## The Setup Wizard

For this configuration step, navigate to the following menu:



When you use the CS141 for the first time, the welcome screen will automatically start with the wizard. Please note that you cannot switch through the masks directly, you need to follow by pressing *next*.

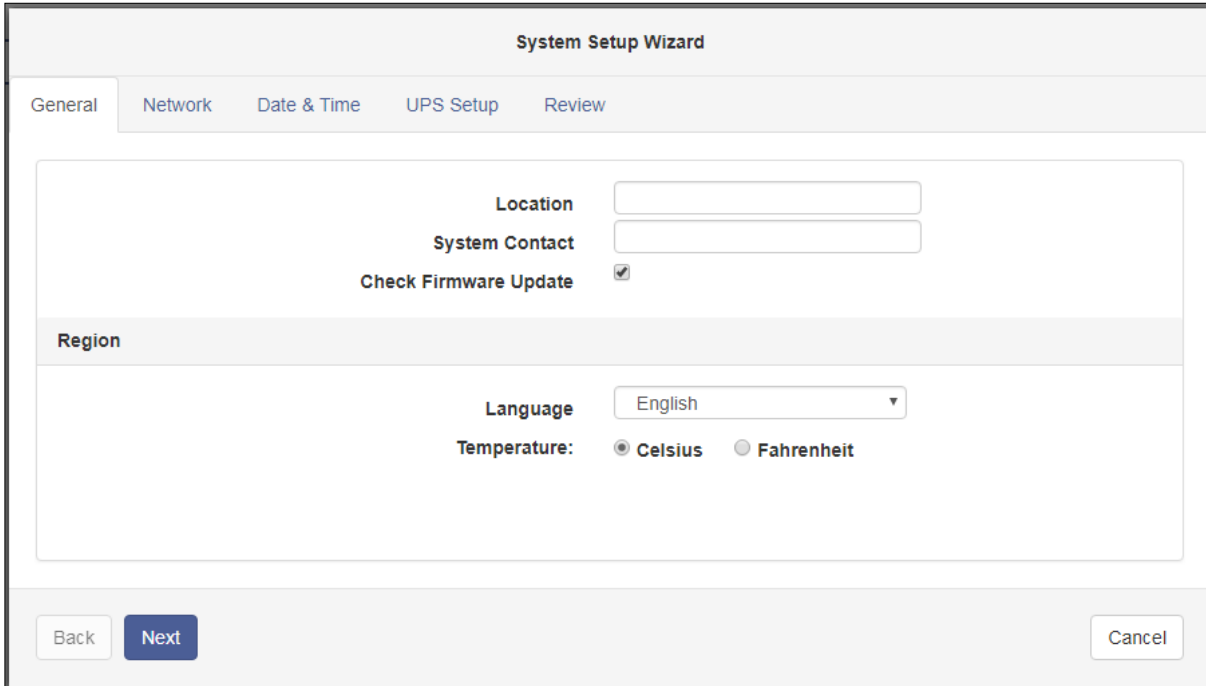

The Setup Wizard helps to set up a basic configuration:

### General

Provides basic information about the location to be installed, system language, responsibilities and temperature scale.

### Network

Enter the network configuration - The necessary data can be obtained from the local administrator.

### Date & Time

Provide basic information about the date, time, and time server

### UPS Setup

Enter information about the UPS the CS141 shall be connected to

### Review

Check data before you finish the configuration process before finishing.

### Note:

The Setup Wizard simply summarizes basic settings and provides a quick and convenient solution that can be used to make or change basic settings. If you want to perform the configuration completely manually, click here Cancel - You can always restart the Setup Wizard in the configuration menu.

*But be careful:* Some entries such as UPS configuration have dependencies to advanced configuration entries the Wizard does not include.

Configuration mode: Basic settings

For this configuration step, navigate to the following menu:



Most settings can be done as long as the CS141 is in configuration mode. Depending on your network settings there could be a problem when performing tests and forwarding functions - they are often not possible on hardware preset 10.10.10.10. Due to this fact it is a good choice to configure all basic settings inside configuration mode and switch to normal mode before starting advanced UPS configuration.

How to configure network settings, open Network:

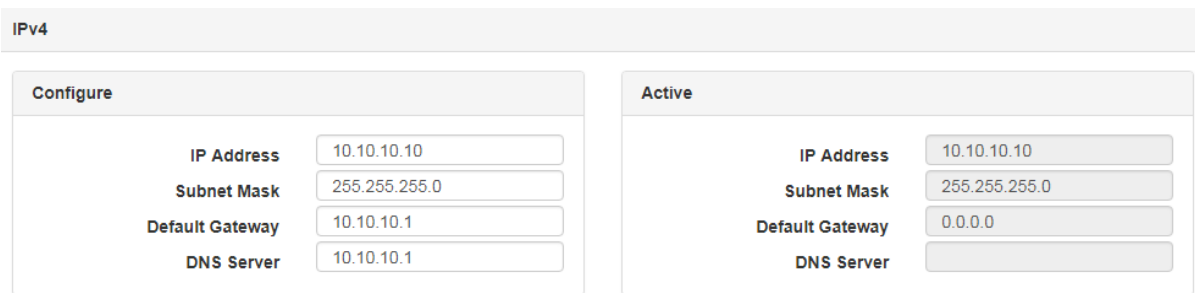

Under Configure, enter the IP address data the system shall use. Active shows the current IP address settings used by the system.

It is possible to change the following settings

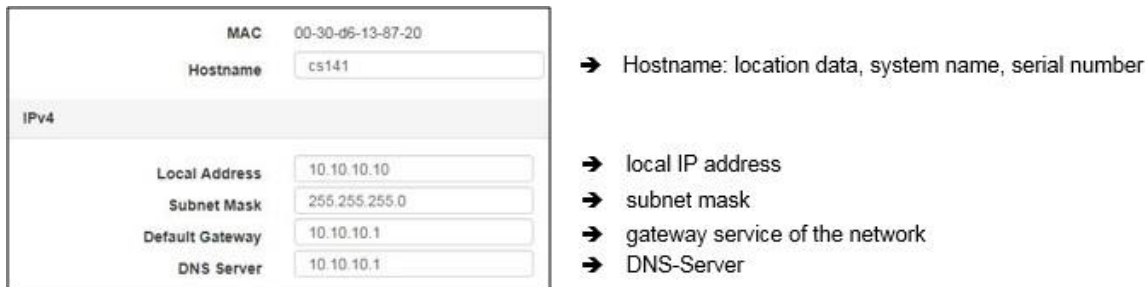

On first startup, the CS141 will get hard-coded information. The required IP address information to enter the operational mode correctly can be obtained by contacting the responsible network administrator. Press Apply to save your settings.

**Note:**

At this point, the web browser redirects you to the new IP address. Since the CS141 is still in configuration mode, you will receive an error message from your web browser. In this case, ensure to work with the IP 10.10.10.10 and press CTRL F5 to refresh the web browser.

For a first configuration, the Network menu is the only setting you currently need to make in Configuration mode. It is possible to carry out all other settings in regular operating mode.

DHCP mode during initial configuration

While booting in DHCP mode, an according server assigns an IP address to the CS141 device. This IP address can be found comfortable by using the freeware tool Netfinder.

Therefore, it is easy to identify the device by the MAC address shown by Netfinder and the address label glued on the CS141 device:

CS141L	1.61	Nicht nötig	Generex (12)	d0-39-72-3b-df-f8	192.168.200.142	
BACSKIT_B4	1.60	Nicht nötig	Generex (12)	00-30-d6-16-b3-4b	192.168.200.148	
CS141BL	1.61	Nicht nötig	ALTERVAC (92)	00-30-d6-12-6f-56	192.168.200.224	
BACSKIT_B4	1.61	Nicht nötig	Generex (12)	00-30-d6-12-60-42	192.168.200.225	
CS131	5.58	Verfügbar (5.62)	Generex (12)	00-03-05-0E-2F-49	192.168.200.227	FB Office

The function open device opens a separate web browser and inserts the IP address automatically.

After login, it is possible to access network settings and change the IP address. after rebooting the device with manual mode setting, new IP address setting is active. By switching back to DHCP mode, these settings are completely ignored and the CS141 falls back to server-assigned address.



The advantage is as many CS141 into the network at the same time without much effort, which are immediately accessible without the possibility of an address conflict. The disadvantage is the fact that in DHCP mode the IP addresses can change dynamically, which means that higher-level or docked shutdown solutions may no longer be able to access or output errors.

Advanced basic settings

For this configuration step, navigate to the following menu:



Enter Location settings

Location data can be read by any software supporting this feature. If used in larger installations with many devices, location data will help to associate installed devices.

Location	<input type="text" value="your location name"/>	→ Enter a physical location the device runs
System Contact	<input type="text" value="administrator, numbers, ..."/>	→ Enter responsible staff or department to be called
Customer Signature	<input type="text"/>	
Check Firmware Update	<input checked="" type="checkbox"/>	→ If checked, the CS141 reports firmware updates

Apply will save the settings and restart according services to activate the new settings instantly. Netfinder will find the new name next to the IP address:

CS141L	1.61	Nicht nötig	Generex (12)	d0-39-72-3b-df-f8	192.168.200.142	
BACSKIT_B4	1.60	Nicht nötig	Generex (12)	00-30-d6-16-b3-4b	192.168.200.204	Allgemeine Anlage 3
CS141BL	1.61	Nicht nötig	ALTERVAC (92)	00-30-d6-12-6f-56	192.168.200.224	
BACSKIT_B4	1.61	Nicht nötig	Generex (12)	00-30-d6-12-60-42	192.168.200.225	
CS141L	1.61	Nicht nötig	Generex (12)	00-30-d6-12-70-36	192.168.200.231	
CS141L	1.60	Nicht nötig	Generex (12)	00-30-d6-14-21-3c	192.168.200.232	

## Regional settings

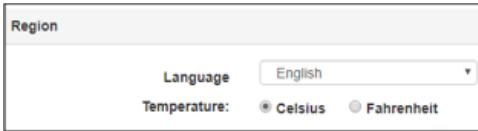

→ Select the language for configuration menus

→ Select temperature measurement scale

Under Language, select your preferred system language. Supported languages are German, English, Chinese (Simple), French, Spanish, Polish, Portuguese

Under Temperatures, select the unit of measure in which to display the temperatures.

### The Difference between Fahrenheit / Celsius

Although initially defined by the freezing point of water (and later melting point of ice), the Celsius scale is officially derived among Kelvin scale: Zero on the Celsius scale (0 ° C) corresponds to 273.15 K, with a temperature difference of 1 ° C which is equivalent to a difference of 1° K - the size of the unit in each scale is the similar. Therefore 100 ° C, the previously defined boiling point of water, equates to 373.15K. Due to the fact the Celsius scale is an interval system, but not a ratio system, means it follows a relative and not an absolute scale.

This is indicated by the fact that a temperature interval between 20 ° C and 30 ° C is the same as between 30 ° C and 40 ° C, but essentially 40 ° C does not have twice the air heat energy like 20 ° C. A temperature difference of 1 ° C therefore corresponds to a temperature difference of 1.8 ° F.

There both scales are used worldwide, it is important to know in advance which measurement scale to use for configuration.

### Note

The CS141 recalculates the values when rescaling the scale and adjusts the settings automatically - but a higher-level system configured to Fahrenheit will inevitably receive incorrect information from a web manager set to Celsius.

This small problem may lead into a big impact, especially if teams are placed inside an international co-operation.

As an example, on December 12, 1998, the Mars Climate Orbiter has entered as programmed the mars orbit, but 170 kilometers lower than planned. Investigations found the reason for this incident: There was a communication issue between two different groups of NASA scientists who performed the trajectory calculations - one used inches and the other meters. They simply forgot to communicate this small fact....

„The „root cause “... was the failed translation of English units into metric units in a segment of ground-based, navigation-related mission software ... “

## Provided services

For this configuration step, navigate to the following menu:

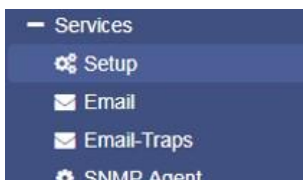

→ CS141 services overview

→ **Basic settings: Service configuration**

The CS141 uses separate system services for communication, which can be started and stopped independently to each other:

This allows activating and deactivating the functions without having to restart the CS141 completely.

While Modbus and SNMP are used as the industry standard inside almost all higher-level monitoring systems, the UNMS server is only necessary if you use the monitoring software UNMS 2 from EXPONENTIAL POWER.

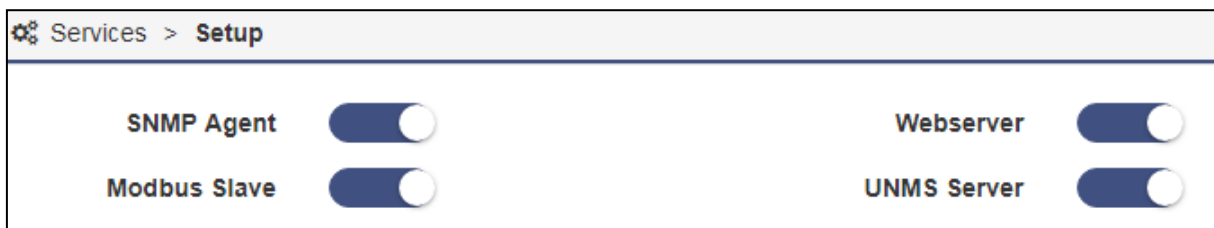

To enable or disable the according service, use the buttons.

## Webserver

to increase security, the configuration by using SSH console is no longer allowed, the integrated web server is the only communication option for configuring the CS141.

Disabling HTTP will restart the device without starting the web interface. By disabling, no further configuration is possible. The CS141 therefore issues a direct alert before disabling this option. Ensure your configuration is done perfectly - Disabling the HTTP Server cannot be withdrawn without physical access to the device.

*Why it is possible to deactivate this server?*

In some cases, it is necessary to ensure a minimum of possible interactions. The CS141 takes care even in this seldom cases:

Depending on its configuration only additional sftp-access is possible in order to download data logs. Therefore, the admin password can be known without consequences of network security.

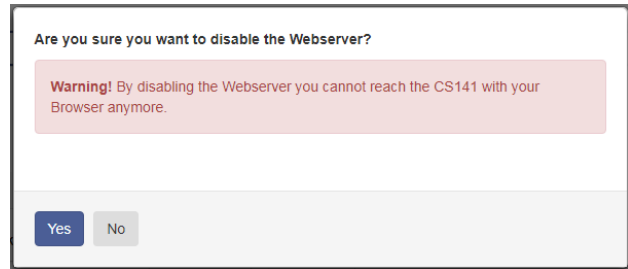

### **Note:**

The rescue system on the CS141 has not only saved the last firmware, but also the last configuration before your update. If you intend to deactivate the http functionality, it is recommended to perform a firmware update before this last configuration step:

By doing it, you will be able to access the system by its build-in rescue mode.

## SNMP

The Simple Network Management Protocol (SNMP) is a network protocol developed by the IETF to monitor and control network elements from a central station.

The protocol controls the communication between the monitored devices and the monitoring station. Thereby SNMP describes the structure of the data packets that can be sent as well as the entire communication process.

It was designed to ensure any network-capable device can be implemented into monitoring systems.

Possible tasks of network management using SNMP include:

- monitoring of network components,
- Remote control and remote configuration of network components
- Error detection and error notification.

With its simplicity, modularity and versatility, SNMP has become the standard supported by most management programs as well as endpoints.

If you want to use SNMP in your network, leave the check mark active for this function.

## Modbus

Fieldbuses are bus systems that connect field devices like sensors or actuators inside a complex operating scenario to allow communication to an according full-automated managing system.

If several communication partners send their information over the same line, it is necessary to ensure communication about fixed rules:

- who (identifier)
- what (measure, command) and
- when (initiative)

To ensure this communication, there are standardized protocols to be used.



### Some historical facts:

The Modbus protocol was launched in 1979 by Gould-Modicon for communicating with its programmable logic controllers and has become an unofficial standard for industrial usage due to its open protocol standard.

Since 1999, fieldbuses have been standardized worldwide in the IEC 61158 standard (Digital data communication for measurement and control - Fieldbus for use in industrial control systems). The second generation of fieldbus technology is based on real-time Ethernet.

### UNMS Server

The UNMS server was specially developed to communicate with the universal network management software from EXPONENTIAL POWER. The powerful successor UNMS 2 communicates via UPSTCP on port 5769. The UPS server service enables or disables availability through this port.

### **Date and time**

For this configuration step, navigate to the following menu:



Surprisingly some system critical duties like logging or running recurring tasks require a reliable Realtime-clock. For this reason, the CS141 provides an own system clock but also offers the ability to query external NTP servers. For maximizing failure security, the CS141 can even set and read the internal clock of the UPS if supported.

### Automatic time adjustment

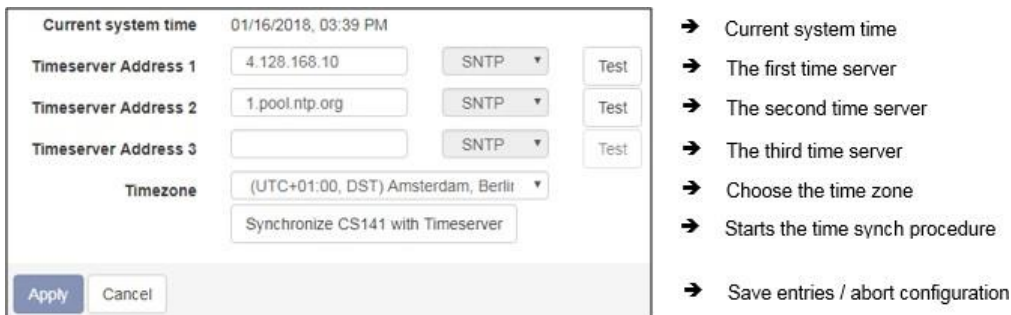

If the network settings are set correctly and CS141 gets an internet connection, you can use the default server settings. In case of a local time server inside a closed-up network segment, the CS141 provides to use an IP address instead of name services. If internal time services used, we recommend the option to enter an IP address although a DNS-Service is available:

If DNS lookup fails, the NTP synchronization will not run.

#### **Note:**

A time server normally provides preformatted time containing information about used time zones. The CS141 calculates the real system time itself from the time zone setting.

If you operate your own time server, this time zone must be adjusted accordingly.

Pressing Apply will save the settings and restarts the time server service inside the CS141 without rebooting. As soon as the time service accepted the new settings, the first-time synchronization follows.

## Tutorial: How to set up a custom time server

In order to use a custom time server, a PC needs an NTP service.

### Important:

Please note in case of using a Microsoft Windows operating system:

From professional Edition, Windows operating systems offer an integrated NTP service. Unfortunately, this internal NTP service provided by Microsoft Windows is not compatible for using with CS141.

Numerous freeware tools located on the Web, which can provide this service, too - therefore it is not necessary to use Microsoft's internal NTP service. These individual providers differ in the points

- User guidance
- Installation
- Pricing for additional features
- Supported Operating Systems
- ..

A well-made little tool is NTP for Windows, we exemplify in this manual. Due to the fact this is a freeware tool, the download source may differ after writing this manual.

Step 1: Download the tool from the Internet:  
Possible download sources would be

The download area of the news service heise.de

<https://www.heise.de/download/product/ntp-fuer-windows-49605/download>

Meinberg, provider of this tool:

<https://www.meinberg.de/german/sw/ntp.htm>

Please note, download links may differ and even change after writing this manual.  
After download, the tool can be easily installed.

Step 2: Start the installation routine. The installer guides you through the complete installation:

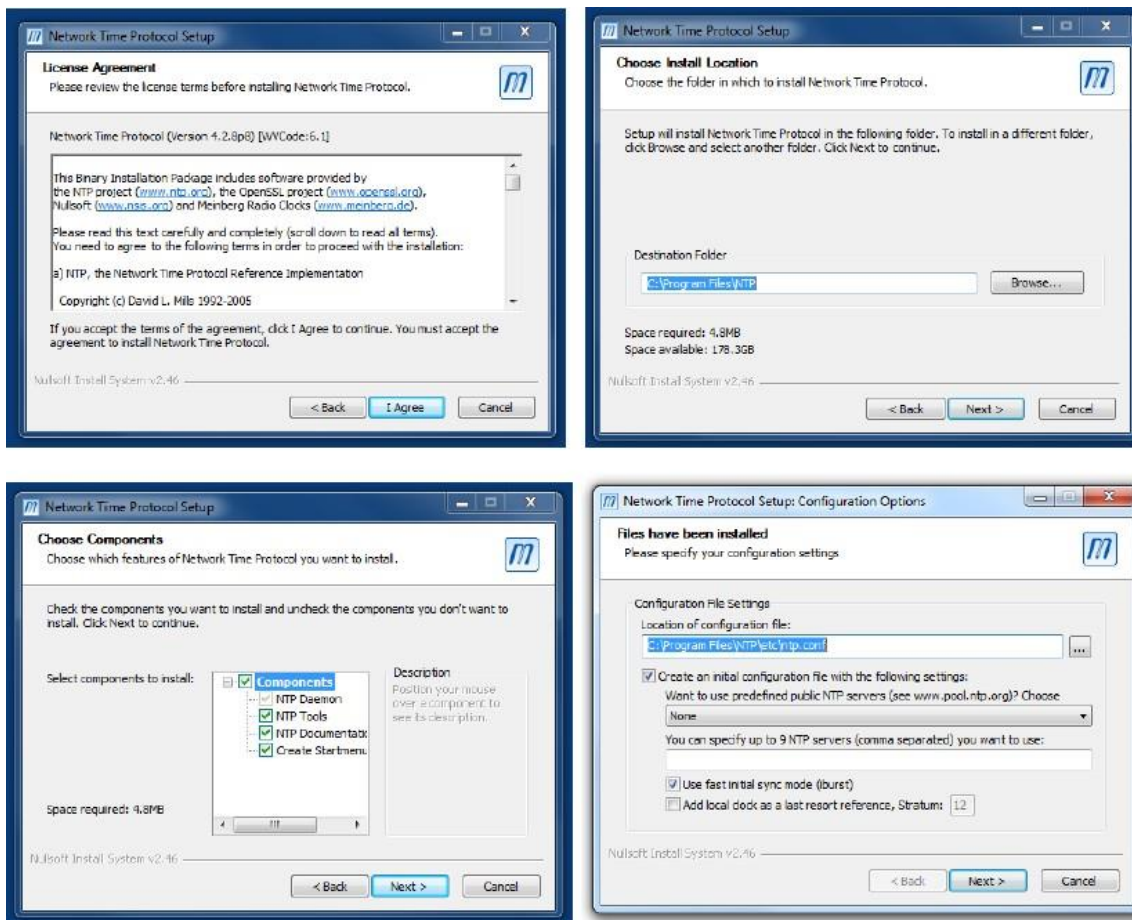

Please note that the features selected and working this example may not match your network. If you are not sure if these settings are correct or have trouble after installing, refer local system administrator team.

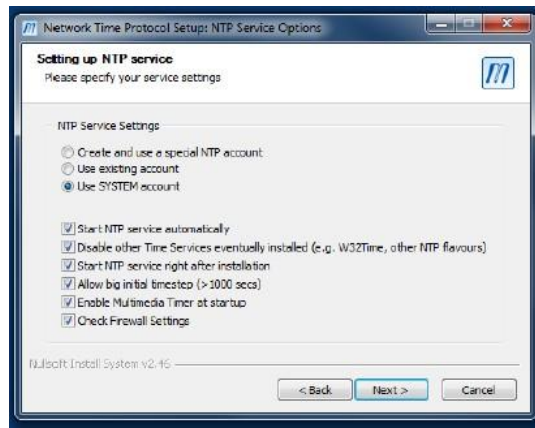

NTP Tool needs an account to provide time services – Normally you can use this option:

- Use SYSTEM Account

The tool asks to create a configuration file during installation. This is necessary for operation therefore you need to allow it - the tool will create and configure this file for you.

**Note:**

After installation, you should restart NTP for Windows using the option *Start as administrator*. Otherwise, it could cause problems during operation. If you are not authorized to use this option, please contact your local system administrator.

Testing the NTP server tool

If the NTP server has been started, you can check the functions with an NTP server testing tool. Download another freeware tool from the following website:

<http://www.ntp-time-server.com/ntp-server-tool.html>

Please note that this tool only returns correct values if the following 2 conditions are completed:

1. The computer with the NTP time server is in the same network segment like the computer containing the NTP testing tool.
2. You use a second computer for testing

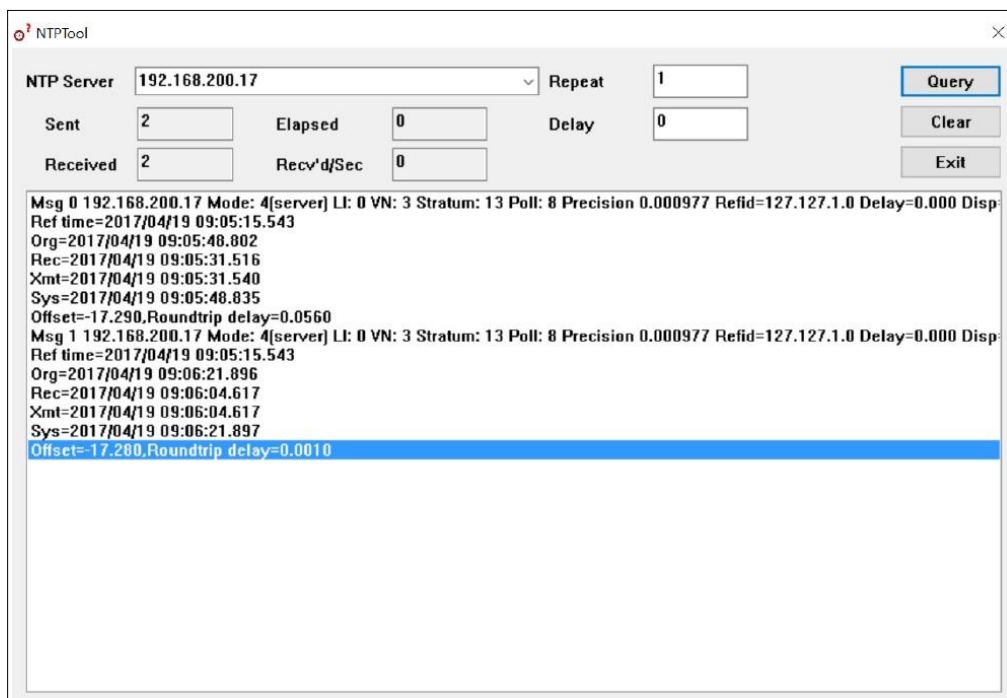

The NTP server in this example is installed on a Windows machine dealing with the IP 192.168.200.17, subnet mask 255.255.255.0. Both the test PC and the CS141 must therefore be located within the corresponding IP address space. Otherwise, the NTP server service will not work.

### Set up time manually

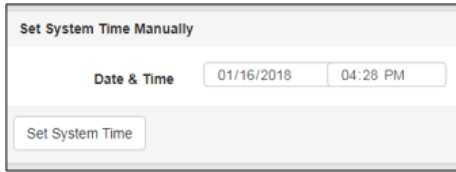

→ Enter Date and Time values manually

→ Save values and set System time

In some case it may be required to enter time manually. with pressing *Set System Time*, the CS141 will accept the new values and overwrite the current system time. The result can be seen instantly under *Current System Time*. To prevent automatic time correction, delete NTP Server. Please ensure the UPS does not correct it, too.

### **Note:**

The synchronization with a time server is performed automatically by the operating system inside of the CS141 device. Therefore, you will not find it in event log files. "Device time synchronized" refers to a special function of the UPS and indicates the internal clock of the UPS has been readjusted by the CS141.

### *Exception:*

You have changed the settings and restarted the NTP service using the Synchronize with Timeserver function. in this case, the according user interface subsystem recognizes a manually triggered execution and will insert a log entry.

### **User management**

For this configuration step, navigate to the following menu:

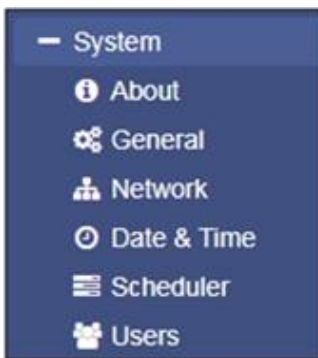

→ Opens the folder System

→ **User management**

The CS141 provides a preset for 3 user profiles to assign different system privileges:

Settings that do not correspond to the corresponding user profile are hidden as soon as the corresponding user logs on. The user names as well as the privileges coming with the users are hard-coded by the CS141. Administrators are only allowed to change passwords:

### *The administrator*

User                    *admin*  
Default-password: *cs141-snmp*

Due to its function, the administrator gets the full range of configuration options. The administrator manages network and mail settings. Furthermore, he is the only user with permission to change the landscape of connected devices.

### *The technician*

User                    *engineer*  
Default password: *engineer*

The technician's user account is restricted to his area of responsibilities - he may access to the functions that relate to technical action. He has the ability to customize and configure available devices and performs the necessary adjustments.

### *The customer*

User:                    *customer*  
Default password: *customer*

The customer has access is restricted to use the system monitors and also viewing as well as downloading a collection of log files - deleting log files is not possible.

## Guest access

User: guest  
Default Password: guest

The guest access is designed to view system monitors without triggering additional functions. Due to this fact, a special feature comes with this user: If necessary, password queries can be deactivated by administrators.

**Guest**

**Anonymous Access**

**New Password**

**Verify**

- Enable/disable password query
- Enter a new password
- Verify password

To use guest access without password query, set the mark for Anonymous Access. Otherwise the CS141 will ask for a valid password.

### Note:

The user *admin* is allowed to manage COM interfaces, but not the user *engineer*. This is necessary due to the fact, attached monitoring systems may need to be prepared for a change inside the hardware landscape before local hardware or components will be disabled for local maintenance duties.

If a technician already "starts" before administrators stop according monitoring services, wrong alarm states may cause trouble.

### How to use guest /anonymous login

The guest access can be used for

Normally, the CS141 only provides information via its web interface if a user successfully logs in - a deep link to view the UPS monitor directly is treated accordingly:

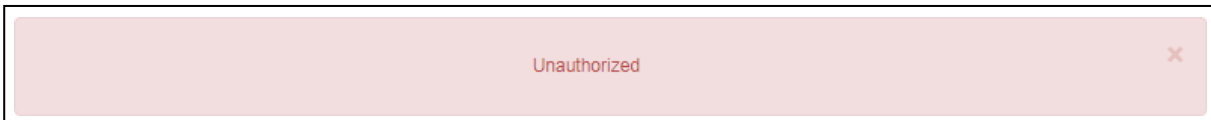

After activating Anonymous authentication, it is possible to view the monitoring screens directly – it is even possible to create a small html page and set up an i-frame to show it inside larger websites or content management systems. This html code may help you to create the html website:

```
<html><head></head>
<body>
<center>
<p>I-Frame zu der USV mit der IP xxx </p>
<br><hr><br>
<iframe src="http://<Ihre IP>/www/devices/ups/page" height="600" width="850" name="iFrame" title="I-Frame zu meiner
USV"></iframe>
</center>
</body></html>
```

As a result, the UPS monitoring screen will appear inside your html document:

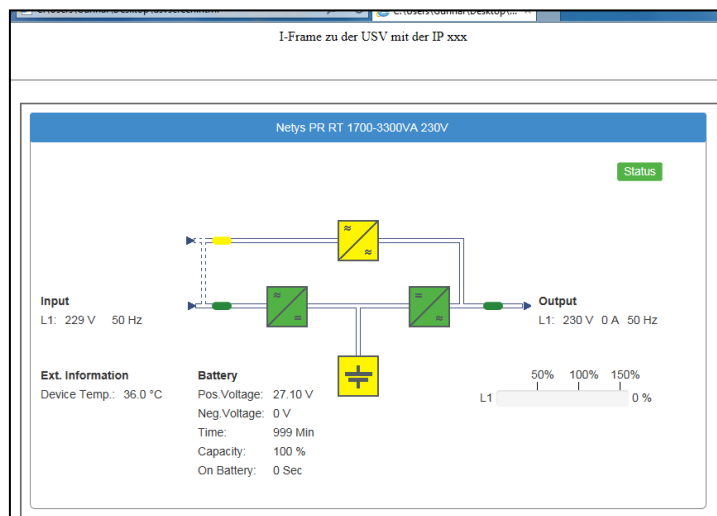

Possible deep links:

- http://10.10.10.10/www/devices/**ups**/page Opens the UPS monitoring screen
- http://10.10.10.10/www/devices/**sensor**/page Opens the Sensor monitoring screen
- http://10.10.10.10/www/devices/**Equalink**/page Opens the EQUALINK monitoring screen.

#### Note

By using the web query directly, you will notice the URL inside your web browser will change. This is because you start a page request, but the web server on the CS141 responds with a different page and will redirect you automatically: Since the page behavior is dynamically, the response page may change accordingly. However, the HTML request is standardized with these three deep links and will be served as long as the Anonymous login is active.

#### Advanced system overview

For this configuration step, navigate to the following menu:



After completing all basic settings, the advanced system overview will list available information about your CS14. The system overview is divided into several sections:

#### System overview

<b>Name</b>	CS141SC	→ CS 141 Webmanager version
<b>Version</b>	CS141-SNMP V1.68.12 180319	→ Current firmware
<b>License</b>	Pro Edition	→ Used license key
<b>Manufacturer</b>	Generex	→ OEM-manufacturer
<b>UPS Model</b>	No UPS model defined	→ Configured UPS
<b>Location</b>		→ Location of the device
<b>Time</b>	2000-01-01 01:44:44 (UTC) Coordinated Universal Time	→ Current system time and used time zone
<b>Uptime</b>	0 days, 0 hours, 6 minutes, 55 seconds	→ Uptime since last reboot

If there are questions or some issues during installation, our technical support will help as fast as possible. Please note, our support needs at least following information:

- Firmware
- UPS model and type
- Uptime since last reboot

#### Hardware

<b>Serial No.</b> 1003600455	→ System serial number
<b>Features</b> bch16	→ Hardware revision

Since 2018, there are two CS141 hardware revisions available on the market. They differ in some aspects inside: All CS141 that are built in 2018 uses a new flash kit. Due to this fact there are some registrations to firmware versions: Earlier versions of CS141 are fully update compatible, but the newer version is designed to run from firmware 1.66.xx onwards. In support cases it is essentially required to know your hardware release:

- bch16 can run earlier firmware version than 1.66.XX
- bch 8 runs with minimum firmware 1.66.XX

Ensure to use the correct firmware, if you are using *bch 8* – feature, old firmware will not run.

Network settings

Network	
<b>MAC Address</b>	00-30-d6-14-21-3c
<b>IP Address</b>	192.168.200.113
<b>Subnet Mask</b>	255.255.255.0
<b>Gateway</b>	192.168.200.1
<b>DNS Server</b>	192.168.200.3

- ➔ MAC-Address of yourCS141
- ➔ Configured IP Address
- ➔ Configured Subnet Mask
- ➔ Configured Gateway
- ➔ Configured DNS-Server

The network settings show the current configuration:

- MAC address:** The Media Access Control is a worldwide unique address to identify a network device. This address is given by the manufacturer and cannot be changed.
- IP-Address:** Shows current IP address assigned to this device. In configuration mode, the default IP 10.10.10.10 is set, even if the IP address configured by administrators differs.
- Gateway:** Defines the network device that is allowed to accept and serve requests to the Internet. By default, the configuration mode uses IP 10.10.10.1
- DNS** The DNS server provides the translation of names and IP addresses into reachable destinations within networks. In configuration mode, it is the IP 10.10.10.1

Connectivity

Connectivity	
<b>Devices</b>	UPS
<b>Services</b>	Webserver, UNMS Server, SNMP Agent, Modbus Slave, Pipe Through

- ➔ Devices according to COM 1
- ➔ Services this CS141 device provides

Connectivity allows a general overview of the options the CS141 currently provides.

Devices thereby merely indicates a UPS can be connected hardwarely to the CS141, but not the kind of model. Services define the software-related services installed and started on the CS141 to communicate with additional devices as well as software.



**Switch to operating mode**

After completing basic configurations, move the slider to the desired position or set the DIP switches accordingly

to enable regular operating mode. After reboot, the device will run in desired mode. if necessary, the device can fall back to configuration mode by setting DIP Switches or sliding switch into configuration mode.

Note that the current switch position will generally take effect after rebooting CS141.

The table below shows the regular operation modes available to the CS141 family.

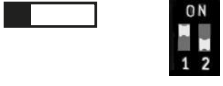
<p><b>Sliding switch to center position / DIP switch 1+2 OFF:</b></p> <p>After booting, the CS141 will run in configuration mode. Hard-coded default IP address 10.10.10.10 is active.</p>	
<p><b>Sliding switch to right position/ DIP 1 OFF + DIP 2 ON:</b></p> <p>After booting DHCP is active and IP address will be assigned automatically. To identify assigned IP address check MAC address of CS 141.</p>	
<p><b>Sliding switch to left position / DIP 1 to ON + DIP 2 OFF:</b></p> <p>After booting, manually configured network settings will take effect.</p>	

**In general, there are two different options to restart the device:**

Option 1 – the cold boot

Briefly disconnect power by pulling the power plug or removing the card from the slot. The device will then boot to the appropriate operating state with the new hardware setting.

Option 2 - Reboot by software

For this step, please switch to the following menu:

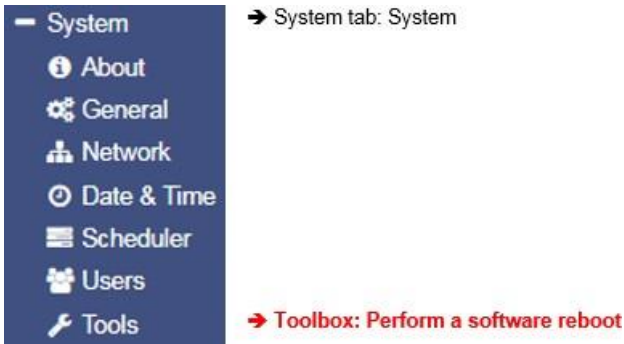

The toolbox is restricted for administration usage only.

After login as hard-coded user admin using default password cs141-snmp, you will be allowed to use the toolbox with extended support features. Please note: The default password is only active in case of no other password was set.

Afterwards it is possible to use the CS141 reboot option.

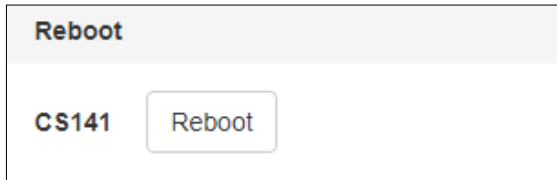

In both cases the UPS will not be restarted, but it only affects the CS141 - your power supply is ensured.

**System notifications**

**Setting up email services**

For this configuration step, navigate to the following menu:



The CS141 provides a variety of options to interact with the environment, external devices, and the network itself.

For this, the necessary services must be configured.

One basic feature is the automatic notification via email and email traps. Due to the fact the CS141 does not provide a complete mail server, a valid email account must be configured.



- ➔ Defines the mail server to be used
- ➔ Defines the port for mail services
- ➔ Mail encryption
- ➔ Mail address of the sender
- ➔ User authentication if required
- ➔ User
- ➔ Password
- ➔ Re-enter password for verification



### Mail server

Enter the mail server to be used.

To ensure a maximum of flexibility, the CS141 allows an appropriate IP address as well as an URL of external mail provider. Administrators can choose between additional external provider or use own mail servers.

#### **Note:**

The fact, your CS141 has a connection to the Internet to access external accounts of large mail providers does not mean an external provider will allow a usage for free. Sometimes they start to block service mails without stating reasons or failure message. It just stops working. In this case, it may be necessary to switch to another provider.

### SMTP Port

Defines the port used by a mail client to communicate with the mail server. Basically, the ports are standardized. In some cases, administrators need to choose own ports configurations to ensure communication; The necessary access data must be obtained from the local administrator.

### Connection Security

Select the encryption type used by the CS141 for sending the emails:

None	no encryption required
If available	STARTTLS
Force encryption	SSL / TLS

### Sender Email Address

Enter the mail address to be shown as sender

### Email authentication – user and password

Depending on its configuration, email servers either use the e-mail address as their username or their own user ID and password to receive e-mails.

For the valid access data, please contact the local network supervisor.

### Advanced Error Log Options

The CS141 offers the possibility to send mail traffic as a blind carbon copy, too.

For some cases, this facilitates the analysis for example, if the sequence of an event has to be examined. With this menu, administrators may specify:

- What else should be sent
- The format to be use
- When it should be sent

The screenshot shows a configuration window titled 'Advanced'. It contains several settings:

- Format:** A checkbox for 'Database Interface Format' is unchecked.
- Log:** A dropdown menu is set to 'Errors only'.
- Automatically send a Copy:** A checkbox for 'for all sent Emails' is checked, and a checkbox for 'On scheduled Jobs' is unchecked.
- To Receiver Email Address:** An empty text input field.

- Select the mail format
- Logging email traffic
- Additional blind carbon copy mail job
- Blind carbon copy receiving mail address

### Format

In some cases, mails will be stored by using database systems. This option enables sending mails compatible formatted.

### Log

This setting toggles the conditions whether a sent mail will be registered by event log. Administrators can choose:

<b>Errors only</b>	Mails that indicate errors are recorded in the event log
<b>Always</b>	Each mail is recorded as "sent" in the event log
<b>Never</b>	The mails are sent but not recorded in the event log.

**Note:**

Under circumstances, automatically sending a copy for all emails may cause a flood of messages - each message will be sent as a copy again.

You may find a similar problem with logging the complete email traffic:

Too many entries in the event log quickly lead to confusing data as soon as you search for special entries within a time window.

With Apply, the settings are transferred to the configuration and the service for sending mails is restarted.

Test mail settings

This function will be available after successful saving mail configuration. It allows to send a test mail to any valid mail address to test the connectivity:

Mail error message

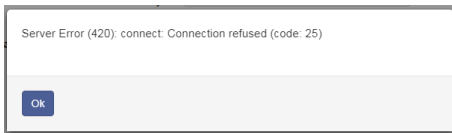

Connection refused

This error indicates CS141 cannot establish a connection to the mail server it is configured to.

The reasons for this behavior can vary. some reasons may be:

- wrong encryption type
- wrong or closed ports
- DNS / Gateway settings are wrong

... or the fact, a mail provider does not allow this kind of mail traffic.

Problems with the mail server?

If you use your own mail server, you can usually take look at the incoming mail log. In general, the reason for rejecting an e-mail is also mentioned there. For online providers, however, the situation looks different:

You usually have no influence on the server and also no insight into the mail log.

As a result, you do everything right, but it still does not work and you cannot figure out why....

There are a couple of reasons, here are some examples:

1. The provider prohibits such service mails. The server simply rejects them automatically.
2. The mailing account must be confirmed manually. The email from unknown recources will be rejected until the user of the account validates the according sending device.
3. The frequency of mail is interpreted as spam. Mail providers react very fast and deny mails from this device even if they allow it in general.
4. Access data are basically correct but the mail server's virus guard is the opponion, the mail is used as a virus carrier. Depending on the settings of the server, the behavior may differ.

**Note:**

Basically, the CS141 also supports the Office365 mail server - be sure to use the correct port and encryption method!

SMTP: Server: SMTP.office365.com / Port: 587 / Encryption: STARTTLS

IMAP: Server: Outlook.office365.com / Port: 993 / Encryption: SSL / TLS

POP: Server: Outlook.office365.com / Port: 995 / Encryption: SSL / TLS

## Email-Traps

Mail trap messages are automatically generated by industrial systems for information and status reports. Retrieved and evaluated by a corresponding recipient they are very useful inside semi- or full-automated infrastructures. The difference to a normal email is that there is no option to enter custom text or define a different recipient.

A valid mail account must be deposited to send mail traps.

For details, please refer the Chapter *Configuring UPS*

In some cases, administrators need to use different mail accounts - if they choose to one Email account, CS141 offers to copy registration data directly from standard mail configuration:

copy from Email

By pressing copy from Email, the CS141 fetches the data already entered without passwords:  
The password of the mail account needs to be verified by entering manually.

## **Tutorial: Email-Traps**

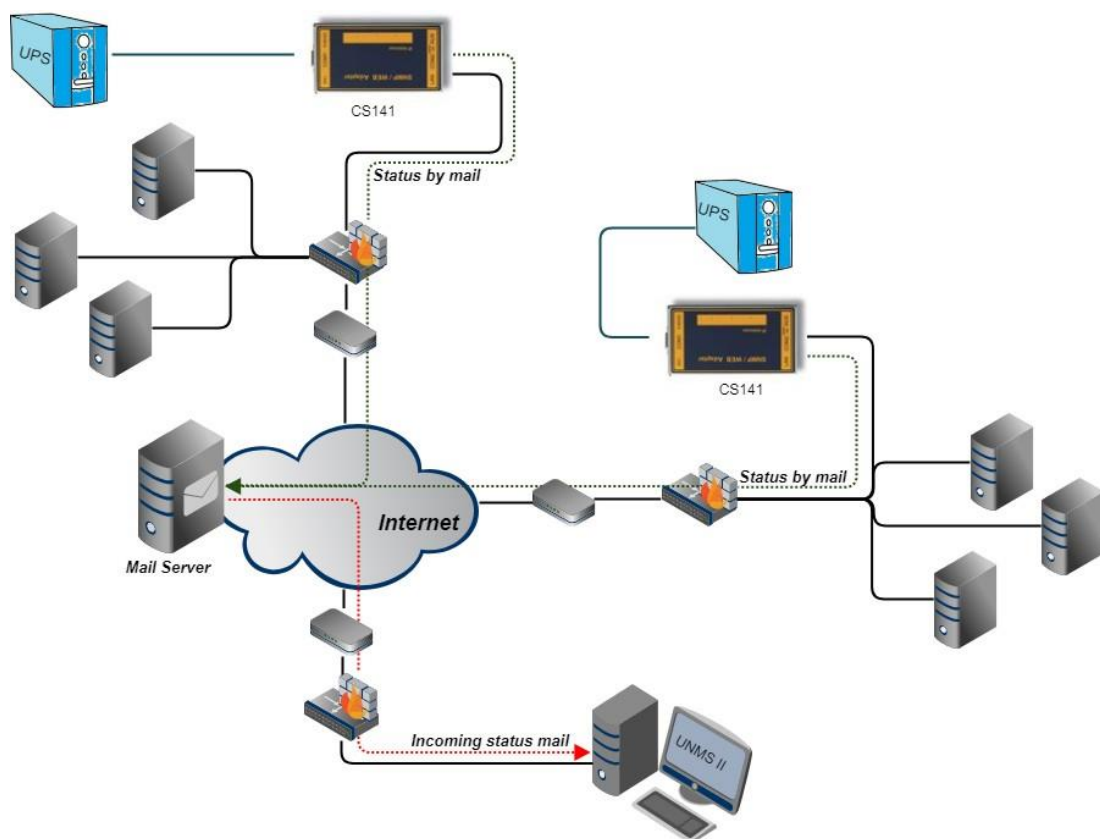

Trap messages are a very popular way to automatically get information from a network. The concept provides that a device sends its status in the form of a standardized data packet as soon as its current status changes. Among other things, the transmitted data strongly depends on the device and its function.

the key feature of a trap message:

The type of transmission is unidirectional - the packet is sent and there is no acknowledgment of receipt. If the device can send the packet, the task is completed. Since the messages are sent only in case of status changes, the destined monitoring tool normally assumes that the last received status received is valid.

Especially in weaker networks or in networks, where many messages of this kind are sent. This is an advantage as soon as either a large number of devices have to be monitored or the network is poorly developed:

Both the required computing power and the amount of status data inside a network can be minimized.

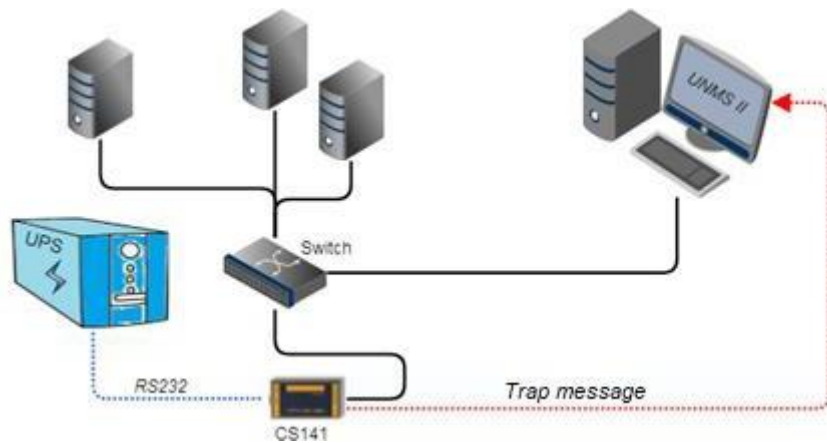

The CS141 is capable to send trap messages to a monitoring software like the UNMS II in order to indicate a status change of a UPS.

Now, there is a problem:

A network grows and for technical reasons, some segments cannot provide a permanent network connection until expensive major network installation works will be done ...

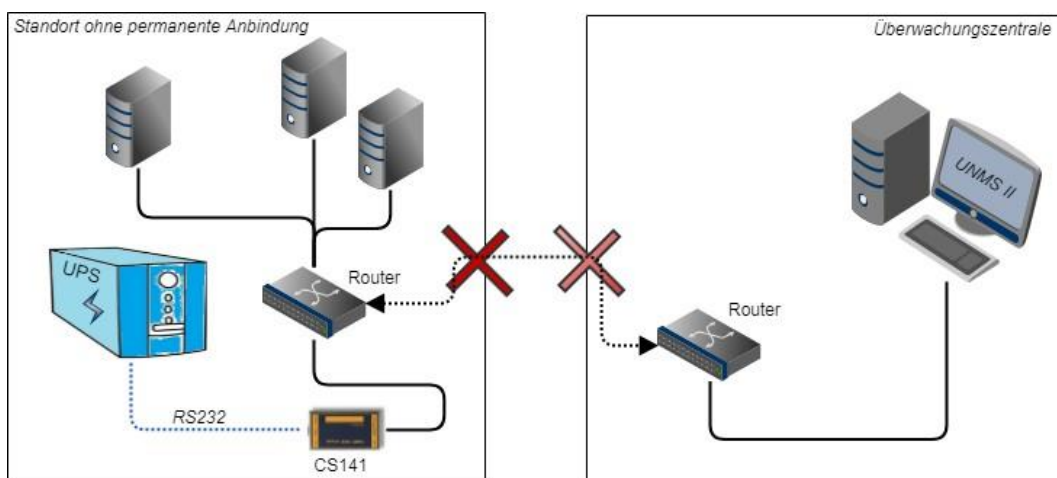

Does the argument of a better connectivity justify the costs of a network implementation or is there a better solution?

With Email-Traps, the CS141 offers an interesting way to meet this situation:

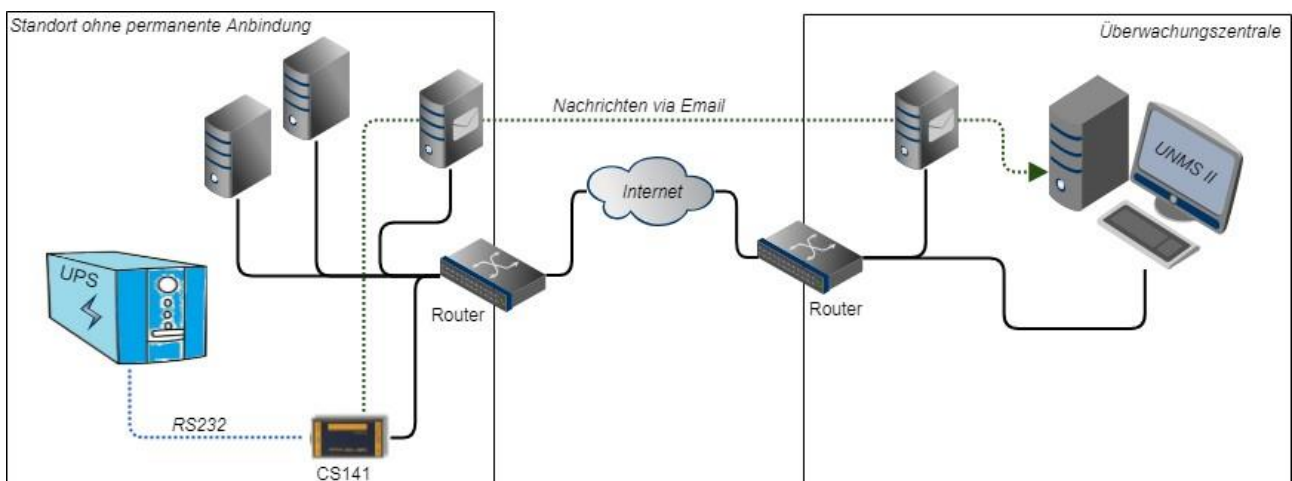

The CS141 uses the e-mail function in order to send an according message if the system status changes - a timestamp ensures that an outdated data package will be registrated but not used for the current system status monitoring. The mail server holds the e-mail until a connection is possible - and forwards this mail to a custom e-mail address a UNMS II can access.

The UNMS II is the recipient. It will look for incoming mails and handle them like trap messages.

**Note:**

The advantage is the fact that local connection options can be used to ensure a basic communication between a device and a monitoring system. The focus is set on ensuring communication - the communication speed depends on the local infrastructure that is available:

The UNMS II displays incoming information directly on arrival, but can not determine when a valid e-mail arrives from a remote system.

**Modbus**

Field buses are bus systems that connect field devices like sensors or actuators to communicate with a parent automation device.

If several communication participants send their information through the same line, it is necessary to determine who (identifier) will send what (measure, command) at a specified time (initiative). To ensure this communication, standardized protocols will be used.

The Modbus protocol was launched in 1979 by Gould-Modicon for communicating with their own programmable logic controllers, and has become an unofficial standard in the industry due to the fact it is an open protocol.

Since 1999, fieldbuses have been standardized worldwide in the IEC 61158 standard (Digital data communication for measurement and control - Fieldbus for use in industrial control systems). The second generation of fieldbus technology is based on real-time Ethernet.

**Note:**

For further information, please refer to the Modbus manual, downloadable from the GENEREX website, visit [www.generex.de](http://www.generex.de).

Modbus providing devices

Modbus is a protocol for serial communication. The data is transmitted using 16-bit registers (integer) or data byte status information.

Using Modbus has many advantages:

- The basic structure of Modbus has never really changed to ensure best compatibility over the years. The number of unified devices provides a stable platform for integration, maintenance and configuration.
- This open protocol has been established as an unofficial standard in many industrial machines worldwide. As soon as a device supports Modbus, it can usually be integrated into an existing Modbus network.

Modbus can be used as single-master protocol

The master controls the entire transmission and monitors accidental occurring timeouts. The connected slave devices may only send telegrams if requested by the master. For remote control and monitoring of equipment, the Modbus interface in each CS141 can read measuring's, events, status information and other things within the master-slave protocol.

**Note:**

If you do not find readings you are looking for, do not assume this could be an error. As an example, if you are looking for rare or custom UPS functions, it is possible that the according UPS communicates this to the CS141 via SNMP, but the manufacturer does not store a Modbus address for these readings.

As a consequence, the CS141 will show it with its own web interface, but cannot serve your Modbus query.

Difference between CS141 Modbus and CS141 Professional

Each device of the CS41 family is capable to handle Modbus over IP. The Modbus devices have an RS485 interface instead of the standard mini-DIN connector for sensors, specially designed for Modbus infrastructures.

Modbus Pin assignment

As a default, a Modbus plug is installed od delivery. The plug can be removed and later simply assembled to ensure a fast and intuitive wiring procedure.

Please note the plug alignment:

Before wiring, ensure the terminal strips are at top of the cable slots - not below them.

By doing so, the following PIN assignment can be used:

Terminal strip



PIN	Description
1	GND
2	RS485 A+
3	RS485 B -

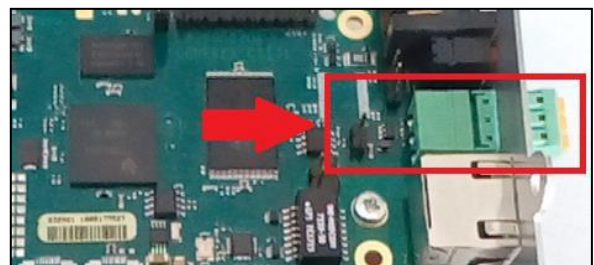

To insert an appropriate cable, pull back the spring mechanism - the clamp will automatically lock the cable at the desired position.

The Modbus Terminator-PIN

Another difference with the CS141 Professional: The CS141 Modbus adapter is capable to drive a real RS485 Modbus protocol - not only Modbus over IP. In case of operating within a real Modbus environment, you can easily integrate the CS141 Modbus adapter.

Since Modbus expects termination resistors on both the first and last devices in the bus network, the CS141 Modbus offers an optional 120-ohm resistor that can be enabled by setting a PINS.

As a default, this PIN is set to OFF - the CS141 is configured to be the last device within the Modbus network. If required, this pin can be set manually.

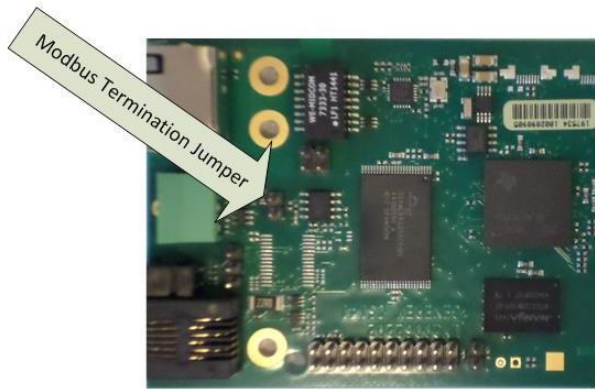

**Note:**  
 In general, the CS141 MODBUS will query the UPS via SNMP and provide appropriate MODBUS addresses and values. Due to this fact, the UPS can be queried via MODBUS. Technically, the UPS is not connected to the Modbus network natively. However, the Modbus controller will not be able to recognize this fact.

Modbus über RS485, RS232 und Modbus over IP

As mentioned, all devices of the CS141 family can master MODBUS queries - the difference is in the details: While the CS141 Modbus version comes with an RS485 interface for native integration into a modbus infrastructure, the CS141 professional version uses a point-to-point connection via RS232 and provides the information via Modbus over IP:

Since Modbus via RS232 is usually used when you want to transfer Modbus data from the UPS to another system or special monitoring software, No terminating resistors are necessary for this connection type.

Due to this fact, the hardware layout of the boards changes if compared:



CS141 Modbus



CS141 Professional

If compared to each other, the CS141 Modbus can be easily distinguished from the CS141 Professional.

Since the external interface and the query via LAN can interfere with each other caused by differences in query timing, the parallel use of Modbus over IP and via internal interfaces is not possible - you need to choose between the query options. With these operating conditions Modbus over IP is available:

1. The external Modbus interface has been explicitly deactivated on the CS141-SCM / LM - since this interface is an exclusive BUS interface, it is therefore a dedicated menu:

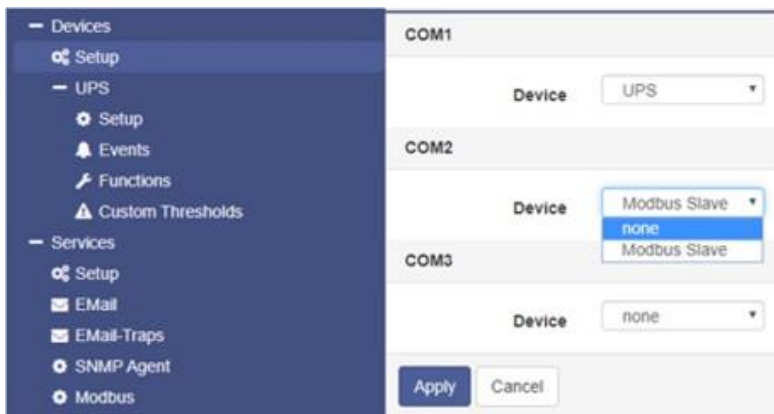

→ COM 2 set to none

The external Modbus interface is disabled and Modbus over IP can be used.

Com 2 set to Modbus Slave

Modbus over IP is disabled and the external interface is enabled.

- Bei dem CS141 Professional verwendet einen multifunktionalen Mini-DIN-Anschluss. Modbus over RS-232 ist daher lediglich eine Anschlussoption, die ausgewählt werden kann:

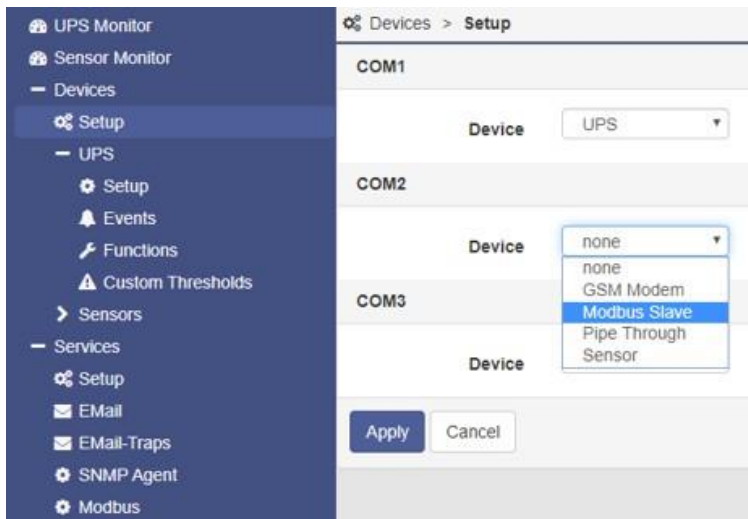

→ COM 2 set to Modbus Slave

Modbus over IP is disabled, Modbus over RS232 is active. The management card can be connect to an external device for Modbus queries.

COM2 set to any other setting

Modbus over IP is active and provides Modbus data via network.

Please note:

Depending on the scope of function, the CS141 will provide different menu entries. In addition to the device setup, the Modbus service must be enabled:

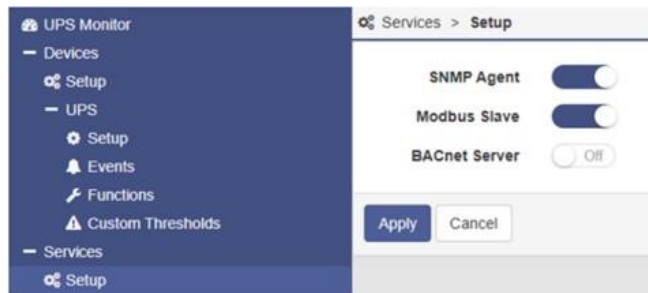

→ The Modbus agent can be enabled or disabled independently to the rest of the configuration of the CS141. If the agent is disabled, Modbus queries will not be answered

### Modbus function codes

The CS141 supports the following function codes:

01H	-	Read Coils
02H	-	Read Discrete Inputs
03H	-	Read Holding Registers
04H	-	Read Input Registers
05H	-	Write Single Coil

Please note a UPS must support this type of commands - the currently available function codes depend on the connected UPS. In general, standard UPS systems provide the functions 03H and 04H. The CS141 is designed not to distinct between these two functions.

Furthermore, the CS141 supports a query speed up to 38400 baud to allow a flexible integration into existing IT environments.

### Modbus error codes

Excepted broadcast messages, where the master device sends requests to the slave device, the master expects a clear and valid response from the slave he queried. If the answer does not match with expected specifications, the packet will be discarded with a corresponding error message.

There are several possible events that may occur when a slave answers to a master's request:

- The slave responds accordingly with a data packet that is both, correct and valid.  
The master will handle it accordingly.
- The slave unit does not receive the request the master device sends.

This event occurs, for example, in case of a communication error. From the point of view of the master the request was not answered. As a consequence, the master will assume an appropriate timeout incident.

3. Master or slave will send invalid queries / answers

Such a phenomenon can occur if the termination resistors are not set up correctly: Although data is being sent, there are clear parity, LRC, or CRC errors within the data packet. Since invalid packets are discarded, the slave will usually ignore an invalid request without answering. However, the master's reaction will differ: In general, he will handle a faulty slave response with a corresponding timeout message.

4. The slave receives a valid request that cannot be answered

This occurs if a requested register does not exist. If the slave unit receives a valid request, but the requested readings are not available, the slave unit will respond a specific exception message in order to inform the master about the reason for this error.

The CS141 provides these error codes:

- 02H

Illegal Data Address

The address data obtained with the valid request is not a valid address servable by the slave.

- 03H Illegal Data Value

A contained value inside a valid request is not an allowed for this slave.

- 06H Slave device busy

The slave has received a valid request, but is currently busy with a time-consuming or time-critical process. As a result, he cannot serve the master for now. For the master, there is no reason to assume a timeout- he will repeat the request some time later.

How to configure Modbus

For this configuration step, navigate to the following menu:

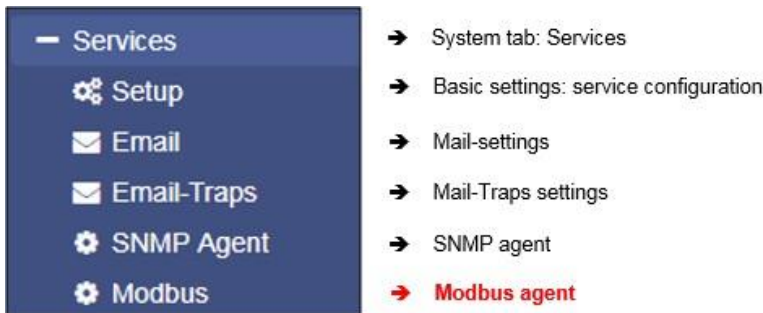

Since Modbus is standardized, the basic configuration is intuitive to handle. To configure the Modbus agent, go to services and open Modbus.

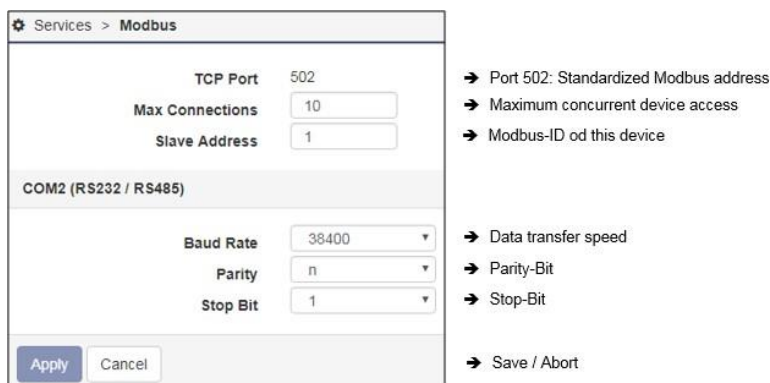

**TCP Port 502**

The TCP port 502 is a static port setting within the Modbus standard that cannot be changed or customized without leaving standards - This port value is hardcoded inside the CS141 source code.

**Slave Address**

The Modbus slave is the ID that make a Modbus device addressable. The Slave ID mentioned by a master's query will cause this device to answer This ID may be customized, but only exist once inside a Modbus network.



**Note:**

Doubling a Modbus Slave Address will not result in a complete network short-circuit - if the ID is requested by a Modbus master, both addressed slave devices will respond. This will cause the Modbus Master to display misleading data accordingly or assumes a timeout due to the fact the data packets are not valid.

In this case, check the uniqueness of the slave address and, if necessary, assign a free Modbus address.

*Baud Rate*

The baud rate defines the data transmission speed for Modbus queries and answers. Please note that the polling speed through the master must be identical to the answering speed configured at the slave to avoid communication lost issues.

*Parity*

When transmitting data in the form of a bit stream, the parity bit will ensure an error detection can be performed.

The value of the parity bit is calculated by the transmitter and communicated to the receiver accordingly. The receiver of the data stream uses the same mathematical algorithm to verify valid data and find corrupt data packets. Thereby Sender and receiver must therefore agree beforehand on how to perform the parity calculation:

The parity calculation can be interpreted as even or odd.

*Example: even parity*

If devices agree to calculate with even parity, the number of all "1 bits" will be counted within the data word. The task of the parity bit is to set the result to an even number:

Therefore, if the number of bits to be checked within a data packet is even, the parity bit must be transferred as 0, otherwise the total count will be not an even value. Differently configured devices would therefore declare an odd or an even value valid and discard other data packets accordingly as invalid.

*Der CS141 offers three options:*

n	No parity control
o	Odd parity control
e	Even parity control

By default, the CS141 is shipped with the value n for no parity check.

*Stop Bit*

A stop bit defines the end of a data word within a data stream and is used in asynchronous data transfer:

Usually, a corresponding start bit is sent before a data word transmission starts. Start/Stop bits allow a receiving device to recognize the beginning as well as the end of a data word inside a data stream. In principle, it is also a high signal, but the level of the signal differs from the subsequent data word.

At the end, depending on the configuration, one or two stop bits are set to determine the explicit end of this data word. As a consequence, no valid data word can be present between stop bits and the next start bit:

The receiving device will recognize these data as discardable and ignores them accordingly.

If data transfer issues cause a synchronization lost, the device will look for predefined bit chains for re-synchronization.

**Note:**

If more than one Modbus device is on the same ID, they will all start sending data to serve the master's query.

Amongst other things, the start and stop bits within the network will begin cross talking, causing problems with the assignment of valid and invalid data packets.

The Stop Bit function defines whether the CS141 should send one or two corresponding stop bits

*Apply/Cancel*

This function saves the entered data and restarts the corresponding services on the fly. A complete reboot of the CS411 is not necessary:

- Apply: Save changes and restart the service as required
- Cancel: Withdraw settings and return to current state.

**Note:**

The standard UPS Modbus addresses can be found in the appendix of this manual starting on page XXX.

The CS141 uses a valid Modbus reading range from 0-65535. Some Programs like "Modbus Poll" use the same range. Other Modbus polling clients may use 1 - 65536 - in this case, you need to correct this by adding 1 to the original value.

## Using Modbus over IP and Modbus RS 232/485 simultaneously

As a standard, the CS141 is configured to use either Modbus over IP or Modbus over RS 232 / 485 to serve a modbus master in order to ensure both, a fast and a stable connection without any timeouts:

- As long as the hardware interface is disabled or assigned to other devices, Modbus over IP will start.
- If COM 2 (or the Modbus interface) is enabled, Modbus over IP will be automatically disabled by design.

For technical reasons, it may be necessary to use both operating modes in parallel - in this case the CS141 can be configured to serve both connection methods at the same time.

### How to use Modbus over IP and Modbus RS 232 / 485 simultaneously

#### **Note:**

In some cases, queries running in parallel from different signal sources may cause a timing problem - caused by sporadic time lags, a Modbus master will incorrectly report a timeout. If you are using the simultaneous Modbus operation mode, please ensure to adapt the master's time window so the CS141 has enough time to send an answer.

To activate the Simultan Modbus Request Mode, these menus must be configured:

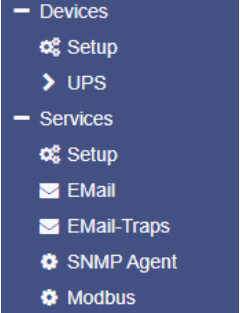
	→	Set COM 2 to "Modbus" <ul style="list-style-type: none"><li>○ For the CS141 SCM, activate the Modbus Interface</li><li>○ For the CS141 SC / L, enable Modbus R232</li></ul>
	→	Enable the Modbus service
	→	Configure the interface

#### Stepp 1: Activate the hardware interface

At Devices, select Modbus at COM 2.

#### Stepp 2: Prepare the Modbus Service

At Services > Setup, set the "Modbus sliding switch" to OFF and press Apply. Wait some seconds and enable the service. Please note, the service will only start with click on "Apply". There is no need to restart the device.

#### Stepp 3: Configure the interface

At Services>Modbus, search for "Activate TCP/IP and Serial simulatnously:

#### **Activate TCP/IP and Serial simultaneously**

##### **To be used with caution:**

In this mode, external TCP/IP requests and also serial requests are served simultaneously, which can lead to loss of some answers on one of or both interfaces.

Therefore, this mode is deactivated by default, and either only TCP/IP or only serial requests are answered.

If "Modbus" is configured on COM2, "TCP/IP" is automatically deactivated and "Serial" is activated; otherwise "TCP/IP" is activated and "Serial" is deactivated.

Click apply to confirm the settings. The CS141 will restart the service into simltanous operating mode.

### Short tutorial: How MODBUS addressing works

When you take a look at the numbers you will notice that this number may tell you ultimately everything. The difficulty is to interpret the number to identify a unique problem and without further explanation, this is a little bit difficult ...

Before you start...

Modbus slaves use a HEX value to send information to a modbus master. After receiving this HEX value, it will be converted into a decimal number. Each HEX value or decimal value stands for a very specific UPS status, which can be interpreted accordingly if a modbus list is available (That's why you need a "MODBUS LIST", you will find this lists in the appendix of this manual).

*Example:*

UPS\_SB\_OUTPUT\_ACT = 0X0004 -> 4 = Inverter on = UPS OK

The query takes place by a pre configured time window configured at the master. As long as the slave gets a valid request, it will answer accordingly- in this case 0X0004. This means, everything is fine with the UPS.

After some time, the master queries again and receives the following answer:

UPS\_SB\_BACKUP\_MODE = 0x0008 -> 8 battery power

On request, the Modbus slave replies with this status: „The UPS is currently running on batteries “

If the reason is an known error status, the CS141 will provide information about the reason, too:

UPS\_SB\_INVERTER\_FAILURE = 0x0200 -> 512 Inverter Error

For the sake of simplicity and to shorten answers, the modbus slave adds the two HEX values and sends a single collective status report.

As a consequence, the decimal system status jumps from 4 to 524: 4 [inverter on], 8 [system on battery] + 512 [inverter error] on request. Since each status can only exist once a time, a unique status report can be interpreted from the result

How does it work in practice now - a logical numerical example

As an example, the Modbus master asks the CS141 at address 109 for a status value and receives the number 56. This number does not mean anything at first, unless the correct list for the interpretation of the number has been stored for address 109. In this case, this list provides all required information about general status information coming with address 109 to interpret the "number 56":

UPS Status	Hex-Value	Dec-Value	Description
UPS_SB_BYPASS_MODE	0x0001	1	power piped thru
UPS_SB_SHUTDOWN	0x0002	2	shutdown ups
UPS_SB_OUTPUT_ACT	0x0004	4	inverter on = UPS OK
UPS_SB_BACKUP_MODE	0x0008	8	battery power
UPS_SB_BATTERY_LOW	0x0010	16	low battery err
UPS_SB_OVER_TEMP	0x0020	32	over temp err
UPS_SB_TEST_ACT	0x0040	64	test in progress
UPS_SB_INPUT_HIGH	0x0080	128	over power err
UPS_SB_OUTPUT_HIGH	0x0100	256	over load err
UPS_SB_INVERTER_FAILURE	0x0200	512	Inverter error
UPS_SB_BATTERY_BAD	0x0400	1024	Battery error
UPS_SB_ECO_MODE	0x0800	2048	eco - bypass
UPS_SB_INVERTER_WARN	0x1000	4096	eco - bypass
UPS_SB_UPS_FAILED	0x2000	8192	prser flag
UPS_SB_COMM_LOST	0x4000	16384	for snmp
UPS_SB_DVG_ALARM	0x8000	32768	SiteManager/SiteMonitor

1. The *Test in Progress* status will use a count 64, this status cannot be.
2. Since the value of the answer is an even number, the status "1" is dropped..
3. The values 2, 4, 8, 16 and 32 are specified within the modbus list and may only be used once.

- Since 2+4+8+16 is not 56, status 32 must be included (56-32=24)
- Furthermore, 2+4+8 is not 24, therefore the next value we are looking for, is 16 (24-16=8)
- Finally 2+4 is not 8, the last valid available number must be 8.

Because all other combinations are invalid, the current system status can be found within 32 / 16 / 8 – all three numbers can be found within the modbus list as seen above.

Other device, same procedure: *The EXPONENTIAL POWER EQUALINK:Modbus list*

As seen in the figure on the right, the basic principle is similar:

In the end, the configured Modbus list decides about available addresses and how to use the values coming with them.

By the way, in some cases, it is necessary to use mathematical formulas for calculating a usable value from a Modbus number. If necessary, it will be explained with the Modbus list coming from a vendor.

**Current and Voltage values**

Current and voltage are measured values, but the interpretation of the number follows the same principles. Once both, the register and the meaning of the value, is known, the returned number can be easily evaluated to determine a requested system status.

*4 – Address 1000 MODBUS/SNMP	(hexadecimal)	(decimal)
BACS_STATE_NONE	0x0000	0
BACS_STATE_RUNNING	0x0001	1
BACS_STATE_CONNECTED	0x0002	2
BACS_STATE_MODULE_LOST	0x0004	4
BACS_STATE_DISCHARGING	0x0008	8
BACS_STATE_CHARGING	0x0010	16
BACS_STATE_DISCHARGING_STOPPED	0x0020	32
BACS_STATE_FLOAT_CHARGING	0x0040	64
BACS_STATE_EQUALISATION	0x0080	128
BACS_STATE_SYSTEM_FAILURE	0x0100	256
BACS_STATE_VOLTAGE_OUTOFRANGE	0x0200	512
BACS_STATE_TEMPERATURE_OUTOFRANGE	0x0400	1024
BACS_STATE_RESISTOR-OUTOFRANGE	0x0800	2048
BACS_STATE_MODULE-ADDRESSING	0x1000	4096
BACS_STATE_MODULE-SEARCHING	0x2000	8192
BACS_STATE_MODULE-INITIALIZING	0x4000	16384
BACS_STATE_MODULE-POLLING	0x8000	32768

Keep in mind to follow the instructions how a number is to be interpreted and refer to the documentation to convert numbers into measurement data. If in doubt, please contact the technical support of the according device.

**SNMP**

For this configuration step, navigate to the following menu:

- Services → System tab: Services
- Setup
- Email
- Email-Traps
- SNMP Agent → **SNMP agent configuration dialog**
- Modbus

Developed by the IETF the Simple Network Management Protocol is designed for monitoring and controlling network elements from a central station. The protocol controls the communication traffic between monitored devices and monitoring stations:

SNMP describes the structure of the data packets that can be sent as well as the entire communication process. The CS141 can fully be integrated into a network with SNMP monitoring. The build-in SNMP agent regulates both - receiving and sending corresponding requests.

→ Version number

→ Configured users and groups

**Note:**

SNMP V1.0 is not officially supported by the CS141. We recommend the use version 2.0 upward. However, since V1.0 is largely included in V2.0, the CS141 will respond to SNMP-V1 requests, but using V1.0 will be out of official supporter's guidance.

The CS141 supports SNMP v2 as well as SNMP v3

The difference that SNMP v2 and v3:



SNMP v2 works on behalf of legitimating an IP address inside user communities, SNMP v3 is based on direct user permissions with name and password.

Configuring SNMP V2:

The overview shows all configured communities:

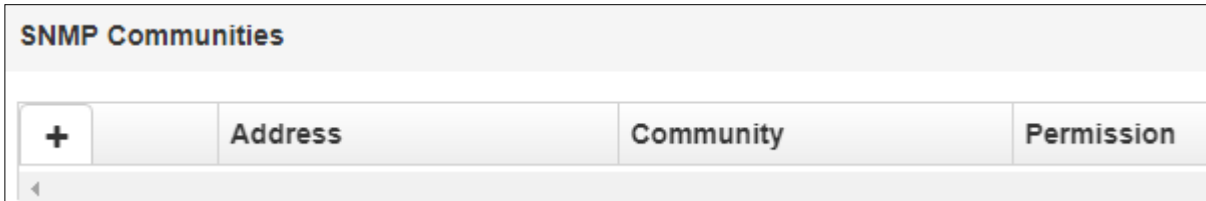

To configure new SNMP permissions, click +

A screenshot of a web form titled "Add Community". It contains three input fields: "IP Address" with the value "10.10.10.10" and a note "IP address required", "Community" with the value "public", and "Permission" with a dropdown menu set to "Read only". At the bottom, there are "Save" and "Cancel" buttons.

- ➔ IP address of the authorized device
- ➔ Community name for access authorization
- ➔ Access authorization type
  
- ➔ Save changes / Abort configuration

*IP address*

Under IP Address, enter the IP address of the authorized computer to allow access to the CS141 device via SNMP v2. Thereby the name of the community defines the authorization group.

*Permission*

Defines permissions during access:

- Read only**      Devices dealing inside this permission group have read-only permissions
- Read/Write**    Devices dealing inside this authorization group can read and write /delete data packets.

Set up trap receivers

Set up trap receivers

What are SNMP traps for?

In principle, an agent monitoring a system can unsolicited send a so-called trap packet to its management station should this be required. Among other things, the status of the monitored device is communicated. On the other hand, the agent can receive and service requests from his manager. There are two ports required by default:

- Port 161**      Required by the agent on the device to receive the requests
- Port 162**      Required by the management station to receive messages

If these ports are blocked, the communication will not work.

## Configuring trap receivers on the CS141

The advantage of the trap messages is that the CS141 can automatically inform about changes in the UPS.



The image shows a configuration window titled "SNMP Trap Receivers". It features a table with two columns: "Address" and "Community". A plus sign (+) is located in the top-left corner of the table area. Below the table, there are two buttons: "Apply" and "Cancel".

To add a new trap receiver, click **+**,

Since trap messages are sent exclusively to inform about status changes, no read / write operations permissions are required.

Enter the recipient's IP address as well as a valid community.

With Save button, CS141 takes over the settings and the SNMP agent will be restarted. The CS141 will not need to be rebooted.



The image shows a dialog box titled "Add Trap Receiver". It contains two input fields: "IP Address" with the value "10.10.10.10" and a label "IP address required" to its right, and "Community" with the value "public". At the bottom, there are two buttons: "Save" and "Cancel".

### Trap receiver test



The image shows a window titled "Test SNMP Traps". It contains the following text: "You can send a powerfail trap and a power restored trap to the receivers defined below. **Please note:** To test newly added receivers, you must save the configuration first." Below this text is a table with two columns: "Address" and "Community". The "Address" column contains the value "192.168.200.17" and the "Community" column contains the value "public". To the right of the table is a "Test" button.

The Trap receiver can be subsequently tested by pressing the test button. The corresponding test message should be displayed directly in your management program.

### **Note:**

Trap messages are automatically generated messages that do not request confirmation - therefore an agent does never know if his trap message have arrived. Du to this fact, a reception logging is not possible.

### Configuring SNMP v3

The overview shows all configured users:



The image shows a configuration window titled "SNMP User". It features a table with two columns: "User" and "Access". A plus sign (+) is located in the top-left corner of the table area. Below the table, there is a scroll bar.

Since SNMPv3 is user-based, you need to configure single users instead of communities. Click **+** to configure a new user:

**Add User**

User: My\_User

Permission: Read only

Security Level: No Security

Cancel Save

- ➔ Add user name
- ➔ Toggle Read/write permission
- ➔ Access control to CS141
  
- ➔ Save changes / Abort configuration

### User

SNMP v3 dispenses with the possibility of setting up authorized IP addresses and user groups. Administrators need to add a local user inside the CS141 device.

### *Read-only / Read Write*

As a standard, any user gets the permission for both - reading and writing. In some cases, this may be not allowed by administrators. To prevent SNMP users from writing data, activate the option *Read only*

### *Authentication*

Defines security level and password control to access the CS141 device using SNMP v3:

- |                            |  |
|----------------------------|--|
| No security                | no passwords or encryption is required                                   |
| Authenticities             | Single password request.   |
| Authentication and Privacy | The connection is additionally encrypted and two passwords are required. |

### **Note:**

In addition to access data, the encryption type must be identical. Otherwise no connection will be established.

### Configure TRAP receiver dealing with SNMP v3

To set up a trap receiver dealing with SNMP v3, you need to create a suitable user. This user can then be selected as the trap recipient in SNMP v3.

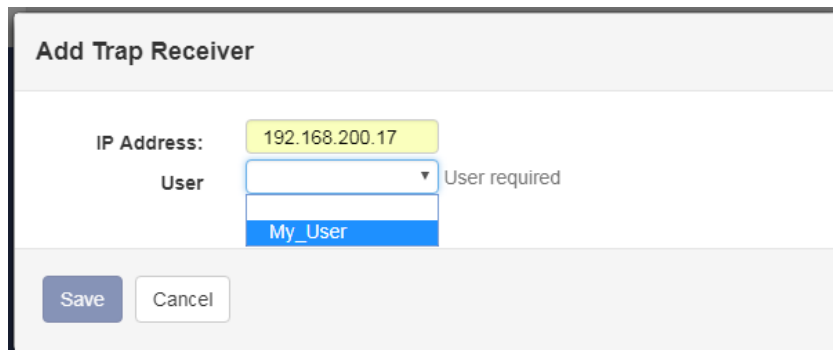

**Add Trap Receiver**

IP Address: 192.168.200.17

User: My\_User (User required)

Save Cancel

### Trap receiver test



**Test SNMP Traps**

You can send a powerfail trap and a power restored trap to the receivers defined below.  
**Please note:** To test newly added receivers, you must save the configuration first.

192.168.200.17	My_User	Test
----------------	---------	------

The Trap receiver can be subsequently tested by pressing the test button. The corresponding test message should be displayed directly in your management program.

### Restarting SNMP agent

This function is available up to firmware 1.78. With firmware 1.80, this feature is an automated background process. No configuration is required.

For this configuration step, navigate to the following menu:



Within a specific and non-standard operating environment, the SNMP agent may stop responding as expected. The CS141 therefore provides a sub system to ensure the SNMP agent is running and alive.



Recovery		
Service	Action	Delay [Min]
SNMP Agent	No Action ▼	1
<input type="button" value="Apply"/> <input type="button" value="Cancel"/>		

In case of the SNMP agent suddenly dies, these options are available:

No action	the recovery service will not bother the SNMP agent with something like restarting.
Restart	the recovery service will restart the SNMP agent if it does not answer.
Delay [Min]	time delay until the Recovery service will restart the agent.

**Note:**

In some cases, SNMP v1 queries may cause a hung up of the SNMP agent. Although not officially supported, the CS141 can work with the appropriate SNMP v.1 queries. The agent recovery service ensures that the agent is automatically restarted in case of doubt.

## BACNET

With firmware release 1.88, the official BACnet standard is supported. You will find this menu only after running an update to at least this firmware version.

### Some facts about BACnet

*Where is BACnet from?*

In 1987, the American Society of Heating Refrigeration and AirConditioning Engineering - known as ASHRAE - founded the standard project committee SPC2 135P - members of this committee included companies like Andover Controls, Honeywell, Johnson Controls, Trane and many others. The thankless task of this convened committee was to define a communication protocol for the monitoring, regulation and energy management of buildings. However, in December 1995 and after some back and forth as well as several submitted designs a solution was found: BACnet was adopted as the ASHRAE / ANSI standard by the American National Standards Institute. Just three years later, the standard was initially adopted by Europe as DIN V ENV 1805-1. BACnet has become one of the most widely used standard in America and thanks to its flexibility, extensive building management, automation can be implemented and easily expanded by new devices.

*The future of BACnet: BACnet over IP*

With BACnet over IP, BACnet goes on:

Existing IT infrastructures can be used, which significantly reduces costs for implementation. Ultimately, you only need a few BACnet-compatible network infrastructure devices like routers and switches with today's standard RJ45 ports.

*Requirements*

BACnet over IP is based on existing TCP / IP structures, but extends these by a lot of functions that are required in building automation. It is important that a BACnet device only works if the corresponding infrastructure supports routing the BACnet extended protocol - for example, routers and switches must also be able to handle BACnet over IP. Alternatively, BACnet-compatible routers must be installed to connect BACnet segments with each via common network hardware.

For the exact configuration of the existing BACnet infrastructure, please contact your local system administrator.

*Required ports to use BACnet over IP*

BACnet uses the UDP protocol and usually these standard ports:

- 47808 or 47809

**Note:**

Unlike e.g. Modbus, the standard ports do not follow standards in port binding. Due to this fact, BACnet does not specify any port that must be used for devices:

You can set up any port for your BACnet system that fits to your IT infrastructure. However, more modern BACnet port objects require support in the areas 47808 - 47823 (0xBAC0 - 0xBACF) and for the dynamic port areas 49152 - 65535

Please refer to your local system administrator for the correct port settings.

For this configuration step, you need the following menus:



BACnet over IP does not work "out of the box" - some configuration work is required. To do this, open the menu services and click on BACnet. The following configuration menu will be presented:

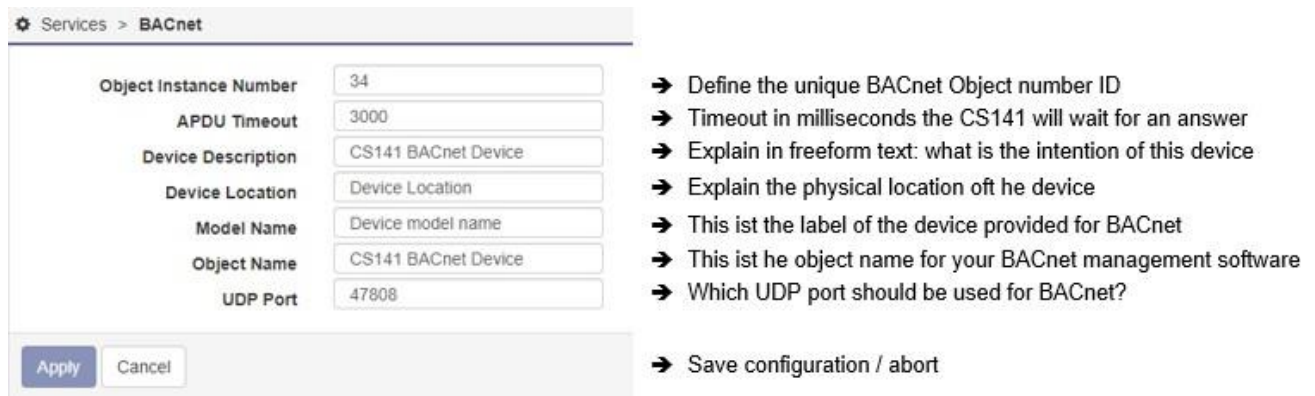

#### Object Instance Number

The instance number is an unsigned decimal number that can be between 0 and 4,194,302. Each device in a BACnet network is assigned a unique instance number. Please note, devices in different physical network segments that can communicate with each other are in the same BACnet network - they cannot have the same instance number! Do not neglect the uniqueness of the instance number just because you are installing MS / TP devices. MS / TP devices also have MAC addresses and must communicate with BACnet / IP devices via a gateway:

They still have to use a unique BACnet instance numbers that are not allowed to be duplicated anywhere else.

#### Note:

With BACnet over IP, the CS141 assigns the ID's for device values dynamically and provides them on request with the necessary value descriptions. Since the internal device ID's may change after reconfiguration, a kind of a fixed and pre-defined "BACnet ID list" like a Modbus list is not practicable or used for BACnet over IP.

#### APDU Timeout

APDU are the "Application Layer Protocol Data Units", the current data packet that is running through your BACnet network. The timeout is the time in milliseconds that the CS141 waits before assuming the loss of a data packet. Why the data packet is lost, can be very different and depends on the network setup.

#### Device Description

Enter a small description of the function of this device. When querying the CS141 with a BACnet browser, this information is displayed as "device description".

#### Device Location

Enter the physical location of the device. In case of problems, you will know where this device is installed.

#### Model Name

This is a free text description of the connected devices, e.g. the UPS or the registration number of a EQUALINK system, etc. This field can be used to provide additional information for technical staff via BACnet.

## UDP Port

As a default setting, the CS141 uses port 47808. However, since BACnet does not have any port restrictions by caused by standards, you may assign a port of your choice to fit the CS141 to your existing IT infrastructure

## Enable / Disable BACnet

After configuration work is done, enable/disable BACnet support at Services> Configuration by setting the slider for BACnet to ON. The CS141 will enable the corresponding service and start providing BACnet data as configured.

## Remote SYSLOG

### What is Remote Syslog?

With an organically growing network, the number devices that create locally stored log files grows. Since each devices follows his own method to provide local log file data, it is a big problem to collect and centralize these data for network error analyzes. Remote Syslog follows the idea that as many systems as possible not only manage their log files locally, but also store them in a standardized data format on a central syslog server:

By doing so, higher level management systems are able to automatically access the files search for problems and errors within a network and, if necessary, to initiate appropriate measures.

### Rsyslog configuration inside the CS141

For this configuration step, you need the following menus:



Rsyslog does not work "out of the box" - some configuration work is required. To do this, open the menu services and click on Setup to start the initial configuration:

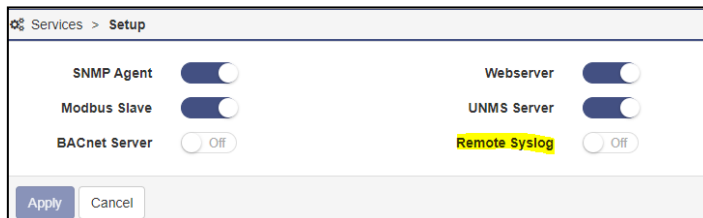

To do this, slide the remote syslog switch from Off to On and confirm your configuration. The service starts and after starting process is finished the according configuration menu is available. Give the RSystemlog service some seconds and than proceed to it's configuration menu by clicking "RSystemlog":



### Remote syslog server IP

With remote syslog, the CS141 sends the locally stored status reports to the IP address of the RSystemlog server. Please note you cannot address directories or "network drives" directly. For the valid IP address, refer to the local system administrator.

### Remote syslog server port

In addition to the IP address, a remote syslog server normally uses a pre-defined port for listening status logs. The default port for using rsyslog is 601. Since this is not an official standard port for rsyslog, the port for the used server may differ. If necessary, refer to the local administrator and change the port setting according to the requirements of the network.

*Accept only TLS connection / Reject expired TLS certificates*

The CS141 can be advised to use encrypted communication only. If checked, the CS141 will reject expired certificates for communication. These functions are only available if you have imported a valid certificate. Please note that with the use of TLS encryption, further configuration on the corresponding syslog server is necessary.

#### Importing a TLS –certificate for RSYSLOG

*What kind of TLS certificate is needed?*

#### **Note:**

The short tutorial "Creating a \*.pem file" in this manual shows you how to create a valid certificate. All you need to do is renaming the certificate into **rsyslog.pem**. To read the according chapter, click on the following link. This link will forward you to the according chapter:

-> [Click to read the Tutorial](#) <-

A pem file is required for operation with TLS encryption. Make sure that both the rsyslog server and the CS141 use the same certificate, otherwise the encrypted communication cannot take place.

At the CS141, upload and install the certificate by placing the file at the upload box:

Place the file via drag'n'drop and click on upload.

If the certificate has been successfully uploaded, the CS141 will show a corresponding message.

After installing the certificate, these additional functions are available:

- *Accept only TLS connection*
- *Reject expired TLS certificates*

Activate the check boxes and save the configuration.

The CS141 takes over your settings and automatically restart the necessary syslog service.

**Upload TLS Certificate for rsyslog**

Drop rsyslog.pem File here  
or click to select

PEM file <no file selected>

The order of the items in rsyslog.pem is important!

```
-----BEGIN RSA PRIVATE KEY-----  
[rsyslog private key]  
-----END RSA PRIVATE KEY-----  
  
-----BEGIN CERTIFICATE-----  
[rsyslog certificate]  
-----END CERTIFICATE-----
```

#### Check list: If the communication with the rsyslog server does not start

1. Check IP address and server port

Larger and well-secured networks may have restricted port access on network devices like manageable switches. As a consequence, the communication is not possible. Please check the internal firewall of the server as well as any 3rd party security solution if the CS141 is allowed to communicate and by the way, check the IP address and port setting whether they are correct.

2. Check network infrastructure

So-called V-LANS are often used in larger networks. Physical ports located on the same switch are stitched to a restricted instance and separated from other ports of the switch. As a consequence, your server may be logically in a complete other network segment but connected to the same switch like the CS141. If your server is in a different network segment, no communication can take place. Check if the all routers and switches are connected and configured as required.

3. Check the certificate(s)

Damaged and incorrectly created certificates (pem-files) mean that no communication can take place. Also make sure that the sender and recipient use matching \*.pem files, otherwise TLS will not work.

## UPS Configuration

### General COM Port setting

For this configuration step, navigate to the following menu:



Depending on the design and model, the CS141 provides up to three additional COM ports fulfilling different functions. Please note in some cases submenus will appear to specify functions of devices connected to CS141. To start configuration, go to Devices and press Setup.

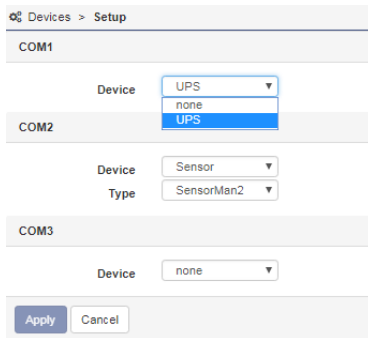

#### Ensure UPS is selected at COM 1:

As a standard, COM1 the setting UPS should be selected. If not, open the drop-down menu and select UPS.

By pressing Apply this selection will be saved and the CS141 will start required services to communicate with the UPS:

Keep in mind by activating this function, a dummy is set first - this is necessary to allow a general access to the corresponding submenus.

The CS141 will display the current starting phase as well as the success of the activation at the upper task bar.

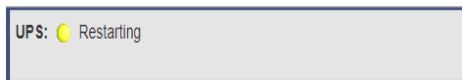

→ UPS service start up routine in progress



menu accessible

→ The UPS feature finished booting, the UPS

Please note that only a dummy without a function has been started at this point, even if a UPS is apparently connected and in operation:

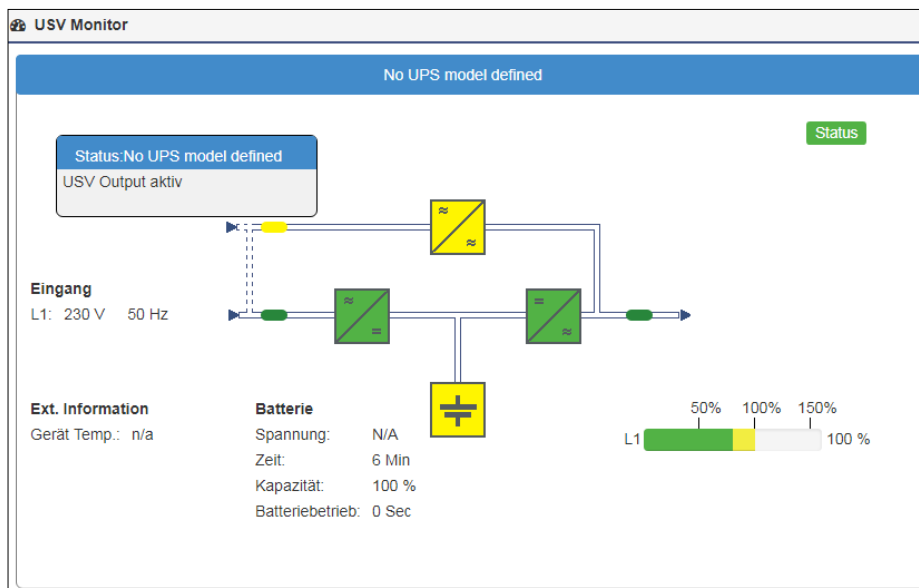

## UPS pipe through function

The COM port 2 is flexible and provides to connect various devices to fulfill different functionalities:

- Sensors
- Modbus
- External modems
- UPS Signal piping

In companion to UPS configuration, the Pipe-Through functionality of the CS141 offers an advantage in UPS signal usage:

The signal received from the UPS can be piped through the CS141 and will be available 1:1 at COM port 2.

Due to this fact administrators can harmonize emergency shutdown solutions even if they need to use two different and physically separated networks:

Physically separated network resources can be managed for their own and use simultaneously the same UPS solution.

The configuration of Pipe Through is done on the Web Manager connected to the UPS. The second Web Manager is configured as described on COM 1 but is connected to the COM2 port of the first Web Manager instead of the UPS.

Devices > Setup	
<b>COM1</b>	
Device	UPS
<b>COM2</b>	
Device	Pipe Through
none	
Sensor	
GSM Modem	
Modbus Slave	
Pipe Through	
<b>COM3</b>	
Device	Pipe Through
Apply	
Cancel	

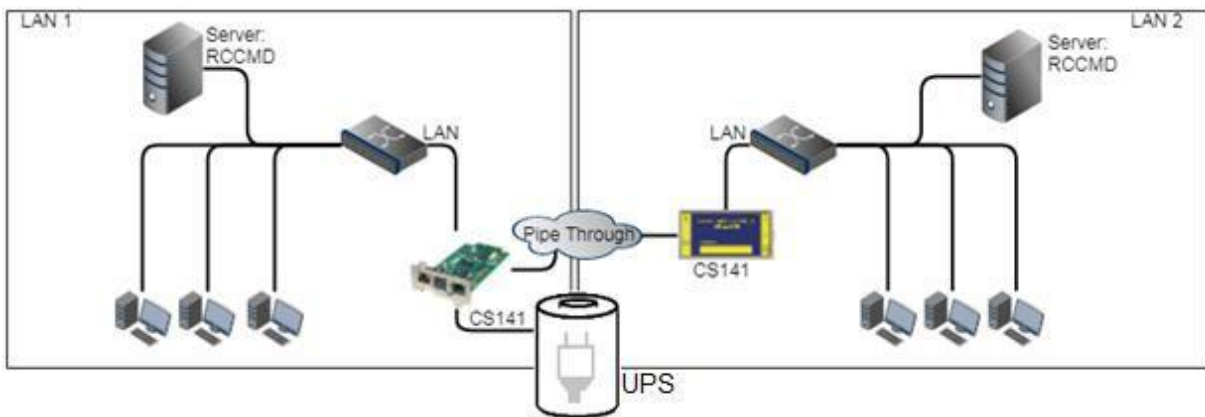

### Note:

When using the pipe-through function, be sure to set the correct COM2 port to Pipe Through. Furthermore, set the same UPS with identical values on both CS141s.

All other settings may differ.

### Configuration of a UPS

For this configuration step, navigate to the following menus:

Devices	→ System Tab: Devices
Setup	
UPS	→ System Tab: UPS Settings
Setup	→ <b>Basic UPS setup</b>
Events	
Functions	
Custom Thresholds	
Sensors	

Proceed to submenu UPS and click on Setup to enter the basic UPS configuration menu.

This configuration dialog allows to choose the UPS your CS141 is installed to – recommended values will be entered automatically by selecting a UPS:

- Choose UPS model
- Maximum output provided by the UPS
- Maximum load provided by the UPS
- Time window the UPS ensure emergency
- Time needed for a complete charge cycle
- Data transmission speed
- Cable to be used
- If necessary, define a UPS ID
- Installation date of the batteries.
- Battery change notification
- Remaining time the UPS shall shut down itself.
- Save settings / Abort configuration process

In some cases, the UPS protocol does not provide the appropriate data. The CS141 will, based on the data situation, independently calculate the corresponding battery life runtime. In general, these settings do not need to be changed if you can select a UPS model directly from the list - optimized configuration settings will be displayed after selecting the UPS.

if your UPS operates with a system configuration that differs to the basic model, it is possible that you need to adjust these default values: In this case, please refer to your local UPS dealer or the UPS manufacturer of the UPS to get the correct values.

Entering wrong values may cause heavy system failures

**Note:**

By default, OEM ID 12 / GENEREX SYSTEMS is set. If you want to use a UPS from a manufacturer that is not listed, take a look at the download area of [www.generex.de](http://www.generex.de) - Search for the firmware for your UPS and install it as a regular firmware update.

Afterwards the corresponding UPS models are available.

Adjustable information about the installed UPS

*Model*

Defines listed default setting of a UPS including the corresponding communication protocol. When your UPS is listed and communication has been established, telemetry of the UPS typically provides all the necessary data that the CS141 needs to calculate and display autonomy times.

Please note that changing the UPS model will also reset the configuration of the UPS events. The CS141 therefore offers the possibility to create a corresponding backup of the event configuration beforehand:

- |              |                                       |
|--------------|---------------------------------------|
| Cancel:      | Do not make any changes to the system |
| Do not save: | Continue without backup               |
| Save:        | Create a Backup of the event handling |

*Power (VA)*

Defines the maximum power in VA the selected UPS in can provide. Exceeding the maximum may cause the UPS getting damaged or even destroyed

*Load (VA)*

This value defines the maximum load connected to the UPS. Even the possibility is given, exceeding the power VA value can damage or destroy the UPS as well as the installed batteries.

The maximum possible value is less or equal to the value entered at Power (VA).

*Hold Time (min)*

If main power fails, the batteries of a UPS will ensure this operating time if 100% load is used. The real-life uptime is determined dynamically by the percent of usage: of you use 50% the hold time will raise accordingly.

**Note:**

Behind the values of power (VA), load (VA), holding time and battery charging time, a mathematical formula is stored - this will allow the CS141 to calculate independently battery operating time and trigger corresponding system events. Thus, allow to use the CS141 even if the UPS protocol cannot provide real-time data - as an example, if a UPS only communicates via switchable contacts or only basic operating states can be detected.

### *Baud Rate*

Different protocols provide different speeds of data transmission. The baud rate defines the speed at which data can be sent and received. An incorrect baud rate can cause communication problems between the CS141 and the UPS.

### *Cable Type*

UPS manufacturers sometimes use specially designed cables for their models. In addition to these in-house developments, there are standardized cable types. These cable types can be used to map different functions and switching states.

### *UPS-ID*

If large UPS systems use more than one UPS module, these modules can be queried directly via a unique ID. „0“ is hereby a something like a broadcast to allow the CS141 search and manage capability to figure out the number of UPS modules. If you change this value, you only get the exact module with this special ID. Otherwise the CS141 will manage all available modules and display them at the monitoring screen.

### *Battery installation date*

The lifespan of batteries running inside a UPS is limited - regular battery maintenance also requires replacement. In order to keep track of larger installations, you may enter the date when the batteries start into operation.

### *Battery too old after*

If entered, the CS141 automatically indicates regular operating period for the installed batteries will expire. By default, the CS141 logs in with appropriate system notes after 48 months. Editing this value will extend or shorten the default time period until the CS141 will start sending maintenance notifications.

### *System shutdown time*

In principle, the system shutdown time is the last emergency shutdown event that will be executed just before the UPS itself will shut down itself to prevent battery damage. This value can be used to trigger the according system event. Please note that this value is an emergency shutdown – it is not suitable to ensure a regular system shutdown.

### *Apply / Cancel*

Apply allows you to save and restart the UPS service on the CS141. Cancel will abort the configuration process and withdraw all settings – they need to be entered again.

### *Battery Health Level feature*

**Battery Health Level(%)**

The battery health level will be automatically provided by CS141 inside the UPS configuration menu if the UPS connected to the CS141 principally carries out battery testing but does not return a reporting value for "Battery test passed / faulty". Thus, the result needs to be determined by comparing two measurements:

Before battery test starts, the battery voltage will be recorded. This value will be compared with the battery voltage to be found after finishing the battery test. The Battery Health Level (%) setting defines the maximum percentage deviation these two values may differ. On exceeding this value, a battery failure will be displayed.

The default setting for this test is 10% deviation - but can be specified with a custom value between 5% and 30%.



**Premium feature: The RFC1628 UPS interface**

In some cases, UPS manufacturers supply systems that the CS141 cannot communicate to. As an example, known problems are the card does not fit to the slot, or that the data stream sent by the UPS is not compatible formatted:

UPS manufacturers have installed their own SNMP card, which offers similar functions but may not be compatible to your flexible and powerful EXPONENTIAL POWER software environment. To ensure compatibility, the CS141 Web Manager offers the option to connect to any card via SNMP. The condition is that the RFC 1628 MIB is supported by the target card. In order to use this function, it is first necessary to configure a corresponding SNMP Agent at the target UPS.

After that enter the access data in the CS141 UPS menu. The CS141 will restart required services and establish a connection to the destination card.

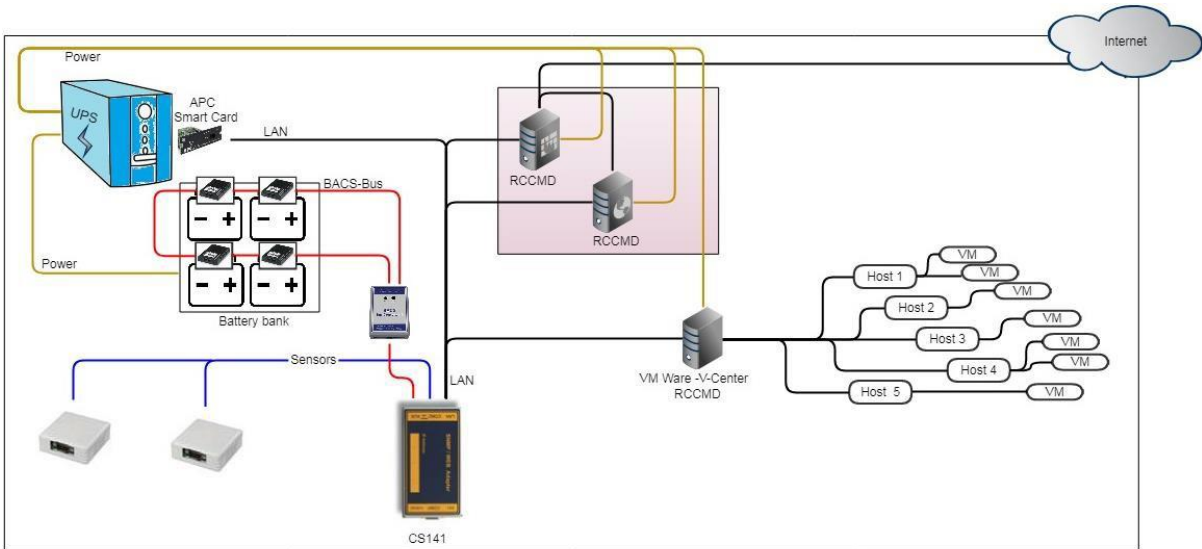

<p>1. Disconnect COM 1</p>	<p>2. Configure RFC 1628 UPS Interface</p> <p>Model: SNMP UPS-RFC 1628 com</p> <p>SNMP Version: <input type="radio"/> 1 <input checked="" type="radio"/> 2 <input type="radio"/> 3</p> <p>IP Address: 192.168.2.1</p> <p>Community: public</p> <p>Apply Cancel</p>	<p>3. Use any SNMP-Card with CS141</p>
----------------------------	--	--

**Setting up the target SNMP card with SNMP v2 at CS141**

Devices > UPS > Setup

Model:

SNMP Version:  1  2  3

IP Address:  IP address required

Community:

Apply Cancel

- ➔ Choose UPS model
- ➔ Select SNMP Version
- ➔ IP-Adresse of the destination
- ➔ Select SNMP Community
- ➔ Save settings / abort configuration dialog

**Model**

Choose SNMP UPS-RFC 128 compliant as UPS model

**SNMP-Version**

Depending on the configuration of your target SNMP card, choose SNMP version 1 or 2

**SNMP Community**

Enter the SNMP Community configured at target SNMP card

**Save/Abort**

Abort will withdraw all settings, save will restart required services. After restarting the services CS141 will automatically establish a communication to target SNMP card.

**Note:**

What is the difference between the RF1628 UPS interface and the APC Smart Network?

In principle, the APC card can handle the RFC1628 standard - you will be able to query basic information about the UPS. However, the APC cards often use their own OIDs. These OIDs are specific to AP and not conform to the RFC1628 standards.

Therefore, it is recommended to use the APC Smart network setting instead of RFC1628 interface.

*Setting up the destination card using SNMP v3 at CS141*



- Choose UPS model
- Choose / change SNMP Version
- IP address of the target system
- SNMP User
- Encryption method
- MD5/SHA password
- ES/AES password
- Apply / abort

The CS141 supports SNMP v1, v2, and v3 in this mode. Enter the access data for the destination card according to your configuration and click *Apply*

**UPS with center tab**

**Tipp:**

The CS141 will provide this function in case of using a UPS with center tab support.

*What is a 'Center Tap'?*

Modern UPS systems divide their single battery pack into two symmetrical pack parts and use a center tap. By using a center tap, they increase the nominal efficiency:

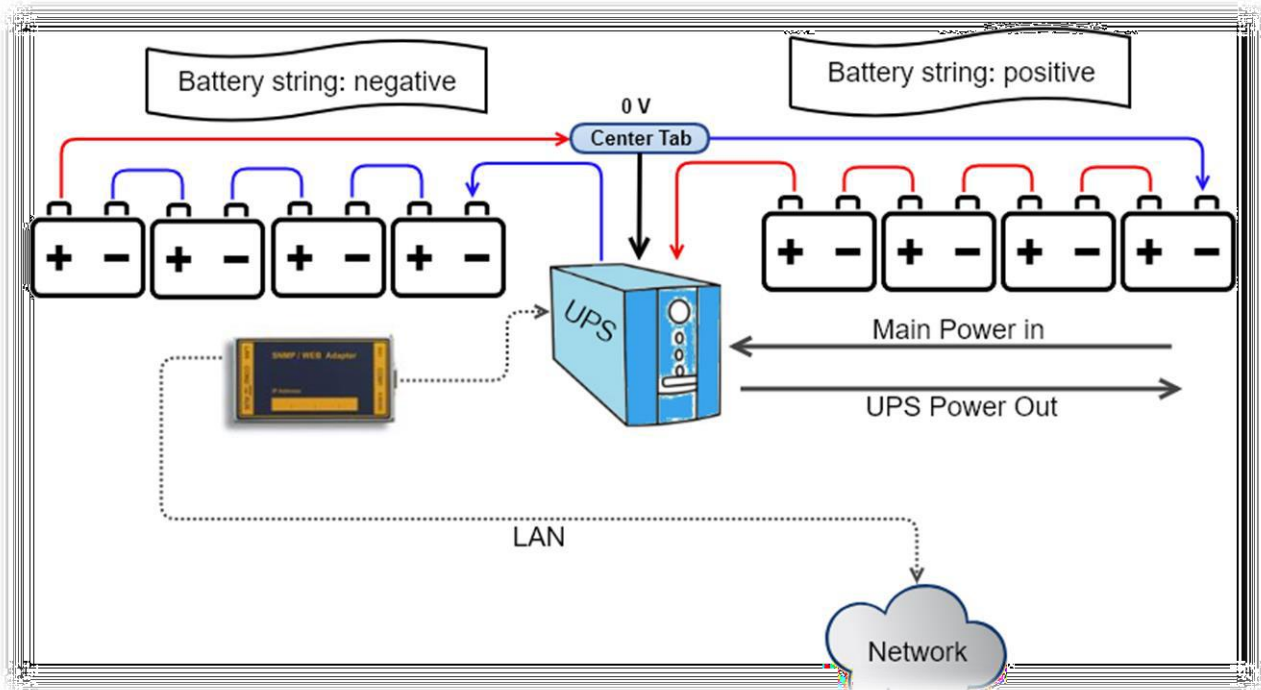

*Measurement difference and charge difference*

The measurement when using a center tap is basically a way of looking at it:

You measure from the UPS to the center tap and then on the other side from the center tap back to the UPS. Since the batteries all remain connected in series, two phenomena can be noticed when there are voltage problems: If a battery has a problem on the negative string, the general voltage for all batteries will decrease.

The individual measurements of the string will show more details:

1. The total voltage for all batteries drops.
2. Measured from the UPS to the center tap at the negative string will indicate the missing string voltage.
3. Measured from the center tap back to the UPS on the positive side shows that all batteries work as desired.

Ideally, a UPS can show itself in which battery site a problem could generally exist - there is no need of inspecting all batteries.

*Where the problems with the UPS start*

A UPS has a blind spot. Although it can measure the differences, dealing with the measurements is a little bit limited:

Since batteries age individually even with the same type of use, the measurement data of the two strings will drift apart at the latest with the natural aging process. As soon as a certain threshold value is exceeded, a UPS system reports a general battery fault, but usually too late:

It is no longer possible to estimate how many batteries have hidden defects due to the imbalance. Most of the time the UPS fails due to the hidden drifting process in an unfortunate moment.

The CS141 can monitor precisely these "hidden drift processes" and issue warnings and alarms in good time if there are questionable values, thus providing the responsible maintenance staff with valuable additional time windows for maintenance work.

#### CS141 settings

*For this settings, you need to use a UPS with a center tap.*

*For setting up this special function, navigat to the following menus:*



This configuration menu is a little bit unusual: On the one hand it is a UPS menu, on the other hand there is a limited purpose how to use this function. Therefore, it was filed under the custom thresholds..

#### **Note:**

This configuration only makes sense if you explicitly use a UPS a center tap is used. Since we are anticipating something at this point, we will only deal with this one aspect of the custom thresholds at this point - further information can be found in this manual in the chapter "Custom Thresholds".

First click on Custom Thresholds in the UPS configuration menu and enable this function:

<input type="checkbox"/> Battery voltage	out of range	<input type="text" value="0"/>	V
<input type="checkbox"/> UPS Temperature	out of range	<input type="text" value="0"/>	°C
<input type="checkbox"/> Input voltage P-N	out of range	<input type="text" value="0"/>	V
<input type="checkbox"/> Seconds on Battery	greater than ▾	<input type="text" value="0"/>	s
<input type="checkbox"/> Battery Autonomy	less than ▾	<input type="text" value="0"/>	m
<input type="checkbox"/> Battery charge	less than ▾	<input type="text" value="0"/>	%
<input checked="" type="checkbox"/> Battery symmetry	greater than ▾	<input type="text" value="0"/>	V
pos./neg. String			
<input type="checkbox"/> Output load	less than ▾	<input type="text" value="10"/>	%

This option enables the monitoring of the general voltage difference - The CS141 looks at both string voltages and determines the general difference between them. If the argument "greater than" applies, an alarm condition exists. This alarm condition is a UPS event to which jobs can be assigned to.

Choose your alarm notification state:

You have the choice between a single alarm job or a warning and alarm behavior. If you only want a single note, just activate the warning state. Otherwise use warning and alarm notification. Please note, that the alarm condition is always is the escalated system state of the warning.

*Warning – the „yellow alert“*

If enabled, the CS141 issues a warning as soon as the two lines have left the configured voltage range. This warning is active as long as the problem persists. Since the voltage drift is a dynamic process, you may receive the warnings in certain phases of use and need to decide if further evaluation of the information is necessary.

*Alarm – the „red alert“*

The alarm can be switched independently of a warning - so if you want to have a warning first and then an alarm, the alarm value must be higher than for the warning (e.g. with a 3 volt drift, the warning is active, an alarm is triggered at 5 volt).

Adding a job

Since these are freeform defined UPS events, the events to the system states are displayed as a regular UPS event. In order to receive a reaction to these events, so-called jobs have to be stored in the UPS "Events" menu. To do this, click on the UPS "Events" menu.

		Job Typ	Wann	Parameter			
<input type="checkbox"/>	<input type="checkbox"/>	Log	Einmal, sofort	{ "text": "Information: Battery symmetry pos./neg. String Threshold Warning On" }			
>	<input type="checkbox"/>	Battery symmetry pos./neg. String Threshold Warning Off		1	1	0	0
>	<input type="checkbox"/>	Battery symmetry pos./neg. String Threshold Alarm On		1	1	0	0
>	<input type="checkbox"/>	Battery symmetry pos./neg. String Threshold Alarm Off		1	1	0	0

The activated custom thresholds can be found as events in the UPS list. As a default, only a log entry configured. Click **+** to add a new job. Please note that some jobs include external accessories, software clients or further configurations such as need an accessible mail server.

**Note:**

A detailed description how to configure the event control handling can be found in this manual in chapter **Event handling**

## UPS-Monitor: Checking UPS Settings

🏠 **UPS Monitor**

➔ Realtime UPS monitoring screen

🏠 **Sensor Monitor**

➔ Realtime sensor monitoring screen

In case of all settings have been entered correctly, administrators can check the UPS's current status in real time by using the UPS monitor. Although the representation may differ depending on the manufacturer and model, some data such as the selected model will be shown:

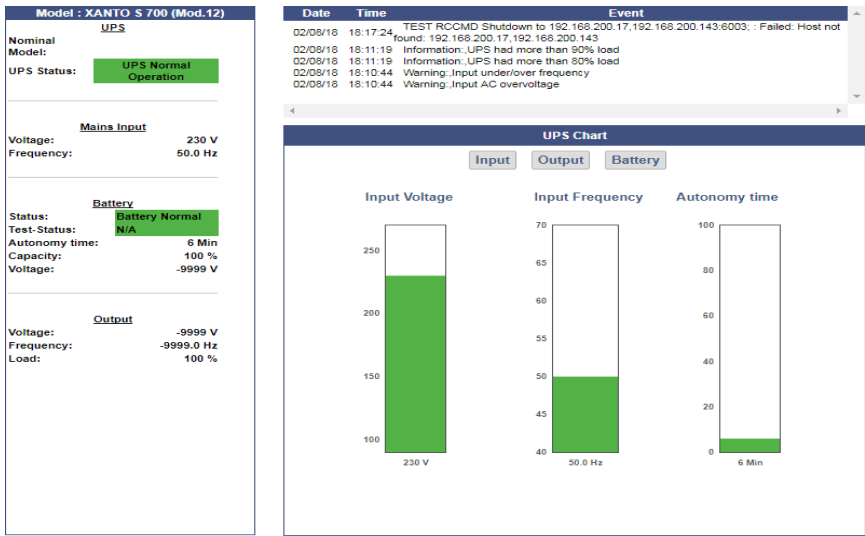

### Overview – the color code

● **UPS:** Test In Progress
 ● **BACS:** Communications Lost

● **GSM Modem:** Communications Lost

● **Sensor:** OK

The upper status bar offers an overview of all connected devices. The color scheme is based on the typical colors of a traffic light. In general, a distinction is made between 4 different system states, which are correspondingly highlighted with a color code. What exactly applies is described in a short text next to the marker.

The colors of the markers will change as followed:

#### 1. Initialization phase of devices and services

<span style="color: yellow;">●</span>	The services are currently starting and search for devices. This notice can be seen both, when commissioning additional modules or when restarting the CS141 for some reasons, as an example a reboot caused by a firmware update.
<span style="color: blue;">●</span>	The initialization phase has been completed and no device was found. A blue marker means that the connection was never established. Please check wiring and operating state of the according devices. In some cases, you also may check your configuration work.

#### 2. Notifications and alarm conditions during normal operating mode

<span style="color: green;">●</span>	Devices and alarms are within the specified parameters, everything OK.
<span style="color: yellow;">●</span>	There is an event that deviates from normal operation and should be observed, e.g. A running UPS test, temperatures reach remarkable values, initialization of devices and services is carried out after a restart, etc.
<span style="color: red;">●</span>	A device reports an alarm state or the conditions for a configured alarm behavior have been met. Communication Lost with a red marker means that an existing connection to a device has broken down.

## UPS functions

For this configuration step, navigate to the following menu:



The UPS Functions menu contains options to perform tests sequences or to configure build-in special functions a UPS may provide. They are tailored to the UPS model used to represent its functionality. As a consequence, the functions displayed for this menu item can vary - some UPSs only allow the on / off state as well as a single test-button, others provide more functionality.

The following functions represent typical menu entries:



### Custom Test

The Custom Test is an on-battery function test using a self-defined time in minutes.

### Battery Test

The battery test checks whether the UPS works properly and the batteries take over. This test usually takes about 15 seconds. This test will not show how long the batteries will be able to take over.

### Full Test

The Full Test will test the batteries until they are depleted. This test can take a long time depending on power and load. The CS141 also accurately measures and determines the runtime under load. Please note UPS systems require stable load of at least 25% to perform a full test.

### Self test

With this test, the UPS checks its own electrical functionality

### Note:

In some cases, a UPS command may seem to fail or an error message may appear. This behavior is based on the fact a UPS receives and confirms a command, but without doing it until pre-conditions are fulfilled. As an example, there must be a minimum charge for a particular battery test - otherwise the UPS returns an error message as a result. This result will be logged accordingly as "error". In reverse cases, it is possible the UPS sends a positive feedback despite errors but indicates an error on the front display itself.

Due to these facts in sometimes the behavior of a UPS system is unique and for some cases unfortunately not predictable.

### UPS Control settings

Depending on design and model, some UPS systems support additional functions to be used for verifying the performance of the UPS. The scope of functionality and configuration possibilities varies considerably and depends on both the manufacturer as well as the model to be used.

Typical functions a UPS may provide:

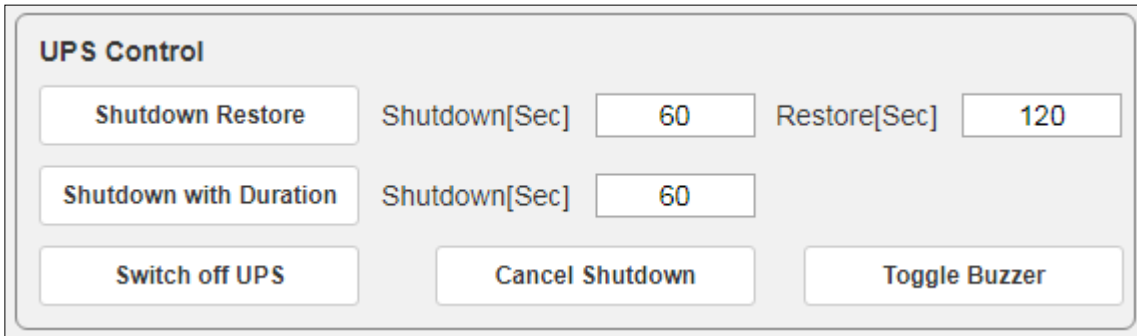

### Switchable output

Depending on the design, some UPS systems support switchable output ports.

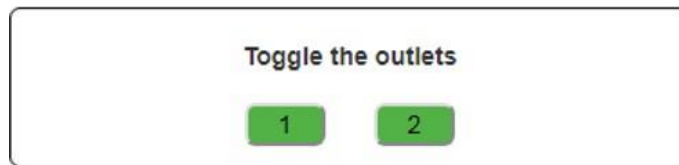

### Note:

Depending on the performance class, UPS systems are equipped differently. Due to this fact, the scope of functions varies.

### Event handling

For this configuration step, navigate to the following menu:



There are many incidents that may require the operation of a UPS. In other cases, devices connected to the UPS may be harmed by different events.

These events could be as an example

- the failure of the main power supply,
- the restoration of the main power supply,
- a defect from inside the UPS prevents taking over to autonomous battery mode
- batteries are depleted and main power is still missing

As a full-fledged manager, the CS141 has the ability to respond to incidents independently, inform responsible personal and even manage event chains to provide a complete shutdown solution inside complex interdependent networks.

### What is the intention of a jobs for an event?

System events are highly dependent on the UPS model to be used and vary in both - designation as well as abundance of possibilities. Furthermore, administrators will find interesting conceptual issues according to the interplay of events and counter-events:

An event receives an action, a job. This job will be executed when the event occurs. These jobs differ in central role as well as its direct function:

- *Information*

These jobs can be executed as often as desired and only fulfill the purpose of the information. Depending on the configuration, information can be sent once or cyclically as long as an event is pending - the nature of the event does not matter. If the situation changes and the event does not come to fruition, an according job will not continue.

- *Action*

These jobs are designed to switch, trigger, start emergency routines, etc. These jobs are triggered as soon as an event occurs. They differ from information jobs due to the fact administrators have to terminate these jobs by using corresponding counter-rotating jobs. In some cases, there are counter-events to be used, others need to be configured manually.

#### **Note:**

##### *It is important to understand the difference*

As long as a power failure occurs, a mail with log files is appended to should be sent every 5 minutes. Once the power failure is eliminated, no more email is written. On the other hand, a job to close potential-free contact as soon as a power failure is detected is executed. This cannot be reverted - even if the main power comes back, the contact remains in closed position. If a warning light is switched via this contact, it would light up until this contact is deliberately opened. A counter-job is needed in case of main power returns.

##### *The following example shows why it is important to understand the difference:*

If the temperature sensor measures critical temperatures, the CS141 will send e-mails and simultaneously close the contact of an air conditioner. As soon as the temperature drops below the critical level, CS141 stops sending e-mails - but the air conditioner needs to run until the temperature has returned to normal condition. This will not work if the contact automatically opens in case of critical temperature is no longer given:

You need to use an active job to switch off the air conditioning system as soon as a certain temperature has been reached.

It becomes problematic if a power failure causes two UPS systems running on separated power input circuits to send a server shutdown command:

As soon as both systems send a valid shutdown command, the server shuts down immediately - even if both UPS systems report a power failure time-separated. If they do not cancel the shutdown command after their respective individual problems were resolved, the server will shut down due the fact, both UPS systems seems to report problems.

### Event handling: Defining a job

The jobs can be configured at any time.

In order to test a job, two conditions need to be adjusted according to the job:

1. Jobs according to e-mails require valid e-mail account data
2. Jobs based on the TCP / IP settings require a valid network configuration

Before continuing configuration ensure all access data are available for configuration, network settings are correct, and that the CS141 is in the regular operating mode inside your network.



Managing jobs

Under Devices, open the UPS submenu and go to Events.

Please note that both the functions as well as designation will differ by usage of different UPS systems.

These are the icons the CS141 provides:



→ Open /close tables



→ Edit an existing job



→ Test an existing job

Symbols providing two functions:



→ delete



→ Checkbox to select multiple jobs or events



→ Add a job

**Note:**

Dual function symbols have two different meanings: Depending on where you serve them, they refer to ALL events or to a specific event or job. This dual functionality allows you to add a specific event to specific or all system events without the need of entering each job individually.

Setting up a job

Managing jobs for a system event always follows the same rules - as an example, the following system events are selected:

>	<input type="checkbox"/>	+	🗑️	Powerfail	3	1	0	1	0
>	<input type="checkbox"/>	+	🗑️	Power restored	3	1	0	1	0

Select > to open the job table:

-	<input type="checkbox"/>	+	🗑️	Powerfail	3	1	0	1	0	0	
				<b>Job Type</b>	<b>When</b>	<b>Parameter</b>					
		✎	🗑️	▶	Log	Periodic all 100s, immediately	{"text": "Powerfail"}				
		✎	🗑️	▶	RCCMD Trap	Once, immediately	{"text": "Powerfail on #MODEL . Autonomietime #AUTONOMTIME min."}				
		✎	🗑️	▶	E-Mail Trap	Once, immediately	{}				

For the event Power failure, a total of 3 jobs are already configured. These jobs were loaded as a recommended default configuration when selecting a UPS. To change or remove, just click on the corresponding icon.

The CS141 allows to delete all jobs within a system event: By doing so, activate the checkbox in the line for power failure and press the symbol for deleting events. After pressing all jobs associated with this one event will be deleted from the list.

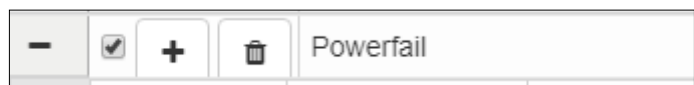

**Note:**

Deleted jobs cannot be retrieved, they must be recreated or restored by using a backup. To prevent accidental deletion, administrators will be prompted to confirm their decision to delete all entries inside an event...

To add a job to the power failure event, press + at the event line. This will trigger the configuration dialog who will guide you through configuration process.

The following jobs are currently available:

Log	Inserts a free definable message into the event log.
Email*	CS141 will send an email.
Email Trap*	CS141 will send Trap Mails
RCCMD Shutdown*	CS141 will transmit a shutdown signal to one or more RCCMD clients.
RCCMD Message*	CS141 will send an RCCMD message to one or more RCCMD clients.
RCCMD Execute*	CS141 will send a command to execute a custom file.
UPS Shutdown***	Turn off UPS
AUX**	CS141 will trigger external relays.
Buzzer**	If a buzzer is connected, CS141 can activate it by using this job.
RCCMD Trap*	CS141 will send an RCCMD trap message.
Send WOL	Wake On LAN - The CS141 will send so-called magic packet to a network device.
Send SMS**	If a GSM modem is connected, CS141 will be able to send SMS.
AUX: Switch Outlets***	As an example, the UPS can be instructed to disconnect the live outlets after a full discharge of the batteries and run a time-delayed release to guarantee a minimum charge of the batteries..
WAKEUP	If two UPS are running in redundancy mode, this custom RCCMD command can be used to withdraw an RCCMD shutdown command

\* Additional software may be necessary.

\*\* This feature may require additional equipment and accessories.

\*\*\* This function is only available to a limited extent: although some UPS systems fundamentally support the functionality, they respond very differently to this job:

Some UPS systems accept and confirm this job, but ultimately decide themselves about execution and timing.

Tutorial: WOL - The „Magic Packet “

*What is the „Magic Packet “?*

In principle, the "Magic Packet" is a standardized data package containing 4x FF. This data packet is sent directly to the MAC address of a network card. Most modern network interface cards support this basic function natively, but for more network functionality, an operating system is usually mandatory.

Preconditions to be met for setting up a working WOL system restart:

1. Depending on your network configuration, these ports must be open:

Port 7 – UDP

Port 9 – UDP

2. Operating system and/or the hardware of the according target system must be configured to handle WOL-Signals.

*Where is the configuration made on the target system?*

In principle, there are two basic scenarios:

Configuration work at the operating system

It is possible to specify whether the operating system allows the a "Magic Packet". If allowed, the operating system can be configured to wake up from hibernation mode. The condition is, however, that the operating system is still running at this point, albeit in some kind of deep sleep mode. If the hardware is turned off physically or a complete power loss happens, the hibernation state of the operating system is gone with the power loss.

Configuration work at the BIOS

In the BIOS setting, the reception of the "Magic Packet" is controlled directly via hardware settings - the network card itself manages the reception and starts the hardware. However, as soon as the computer is just in a hibernation mode, the hardware is not responsible to manage a restart - the hibernated operating system has to trigger and manage the wake up. The network card will only start the hardware via WOL in case of a complete power loss during hibernation mode.

**Note:**

Virtualized systems are a little bit awkward, because the network interfaces are normally virtualized: The Possibility to pass a WOL signal through a physical network interface in order to start a virtual machine depends on the scope of functions the virtualization solution itself provides. If in doubt, please contact the technical support of the corresponding virtualization solution.

*OK, ... but which settings must be done?*

That depends on what you want to achieve.

If your (physical) computer normally needs to wake up from hibernation mode, the network options of the operating system must be configured to manage WOL packets. When the computer is usually switched off, powering up is managed by the hardware. You need to configure the hardware:

If you want to ensure an identical result in both cases, then it is recommended to carry out both settings accordingly

### 3. Setting up the CS141

All devices of the CS141 family use colons as separators for the MAC address values.:

Example:

<b>Job</b>	Send WOL ▼
<b>Parameter</b>	
<b>Port</b>	9
<b>MAC-Address</b>	00:AC:0F:FE:00:00
<b>Password</b>	

Create multiple single jobs to power up different devices via WOL. It is not possible to set up one job with different MAC addresses.

#### Note:

Since the WOL signal is sent to the MAC address of a network card, the IP address and the subnet mask do not matter, as they are used by higher system authorities. These higher network authorities must be up and running first. The port only becomes interesting in case of the WOL signal has to be routed across networks by a router to other network nodes. Usually port 7 or port 9 is used for this function, but you have to keep in mind that the ports are managed by the system administrator of the network and can be freely adapted to his preferences and security approvals. In other cases, it is possible that the network hardware may use a hard coded port number and blocks all other signals as a kind of intrusion. In case of your WOL-Signal does not work, check the local IT infrastructure if the WOL signal was filtered or blocked by other network devices.

### UPS Shutdown definition

#### Why is the job UPS shutdown a little bit tricky?

A UPS performs a UPS shutdown to protect the batteries from a deep discharge. The UPS is physically shut down and turned off. The time when a UPS performs this action or how it reacts to a triggered action by scheduler or via UPS functions already varies even between the models within a manufacturer - in addition, each manufacturer uses its own definitions for to protect batteries. But due to the fact the UPS has been physically turned off, counter events cannot be configured.

#### Configuring UPS Shutdown

<b>Job</b>	UPS Shutdown ▼	→ Choose the job
<b>Parameter</b>		
<b>Shutdown Time</b>		→ Time delay until system shutdown
<b>Restore Time</b>		→ Time delay until system restart
<b>Type</b>	1	→ Toggle shutdown type

#### *Shutdown time in seconds*

Defines how long the UPS should maintain operation before shutting down itself.

#### *Restore time in seconds*

When the main power supply is restored, the UPS waits for the preset value in seconds until it starts up again.

#### *Type*

With this setting the UPS will be turned off or turn on. Two different settings are possible:

- 1 The UPS switches off the outputs but remains in operation mode.
- 2 The UPS shuts down and turns off completely until the main power is restored.

### How to use the job UPS Shutdown

This job cannot map both settings together.  
Depending on the desired operation modes, at least two jobs are required.

As an example, it is possible to use different jobs to complete the following sequence:

- Switch off outputs after 3 minutes
- Shutdown the UPS after 4 minutes
- Turn on the UPS 2 minutes after the main power supply is restored
- Activate the outputs 15 minutes later

Note that the shutdown time and the restore time must be correctly nested for both jobs.

In this case, enter either a 1 or a 2 depending on the desired event.

### Search and display jobs

Event	Jobs	Log	E-Mail	E-Mail Trap	RCCMD Shutdown	RCCMD Message	RD
<input type="text" value="contains..."/>	<input type="text"/>						

The Search function is a quick method to find jobs configured within events.  
The CS141 provides two basic options:

#### Event contains...

Search for a UPS event. By typing a part of an event all events according to the text fragment are listed.

#### Jobs

Lists events containing a number of jobs defined by this value. As an example, if you want to know how many events contain 3 jobs, enter 3. All events containing this number of jobs will be listed.

### Configure a Job

Press **+** at an event to open the job configuration dialog.

**Job**

Different jobs provide different parameters to be configured

**Example 1: Log** – Enter the text CS141 shows at Event Log?

**Parameter**  
Text

**Example 2: RCCMD execute** – Due to the fact RCCMD needs IP address data, the parameters will change.

**Parameter**  
IP  Broadcast   
Port   
Command

#### Note:

The parameters adapt dynamically to fit to the according job. If the job type does not support a parameter, it will not be provided for configuration

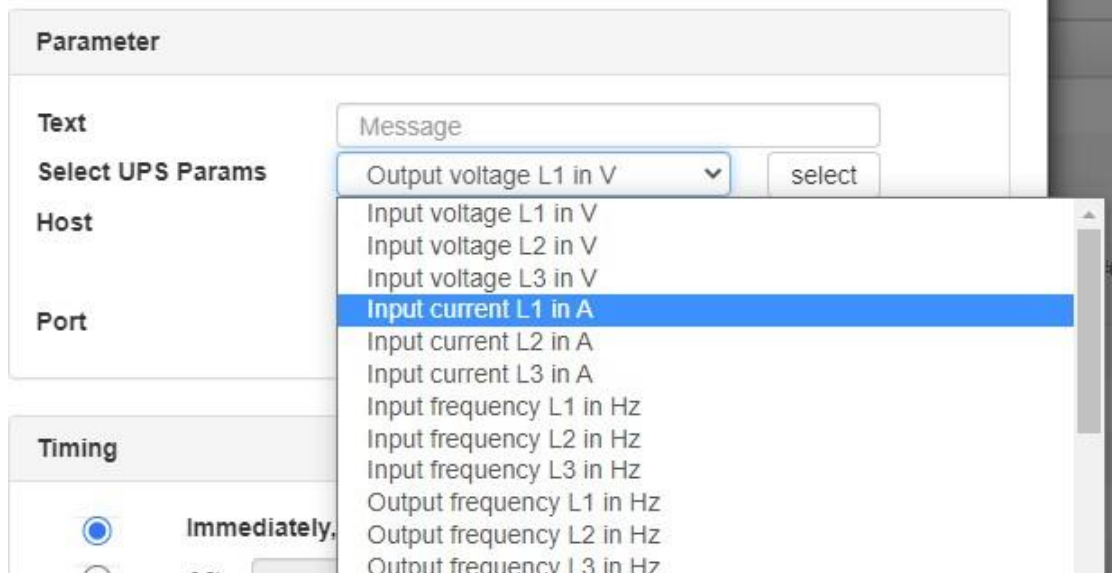

Choose the desired status information parameter and press select.

The CS141 will automatically insert the corresponding function in the text field. Select as many parameters as wanted one after the other. In case of a corresponding function cannot be served because the according function is not supported by the UPS, the message will show NA for not available.

### Job timing

The CS141 provides many system events a job can be assigned to. Some jobs allow to configure advanced timing:

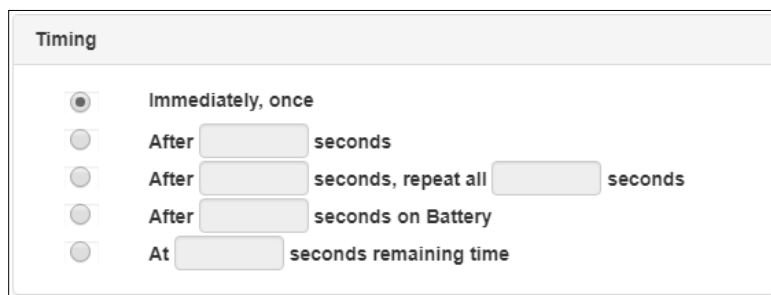

- |                                |  |
|--------------------------------|--|
| Immediately, once              | as soon as an event happens, this job is executed at once and not repeated.  |
| After XXX seconds:             | The CS141 will wait a pre-defined time in seconds and then execute the job. If the event is no longer active before time is up, the job will not be executed.  |
| Repeat all XXX seconds:        | The job is repeated cyclically until the event no longer is no longer active.  |
| After XXX seconds on battery:  | The event forces the UPS will to switch to autonomous mode. The job will be executed if the UPS remains a pre-defined time in this state. For example, if 300 seconds are set, this job will only be executed if the UPS operates in autonomous reaches 300 seconds. |
| At XXX seconds remaining time: | The job is executed when the remaining UPS operating time is reached or undershot. Note based on the current load this time value becomes flexible.  |

### Time management of jobs

The time management of jobs to be performed is difficult since one has to distinguish conceptually between two different points of view. The following example according to the event power failure illustrates the differences:

In case of a power outage, the UPS will take over power and protect the servers until ...

1. The batteries are depleted
2. Main power is available again

As soon as the UPS runs into autonomous mode, it will start two different timers:

*A linearly advancing time in seconds starting at 0.*

If a job is to be executed after 45 seconds, it will only be executed if the event is pending for at least 45 seconds. If the event is terminated before consequently the job is not executed.

*A relative clock that counts backwards depending on the connected load currently used.*

This becomes tricky if the UPS will operate with a load of 100%

If some of the machines connected to the UPS will be shut down after 3 minutes and cause the load to drop to 50%, it will take effect this way: Because of dropping load, the clock would jump from 4 minutes to 7.5 minutes.

*Both methods to count come with specific advantages and disadvantages:*

The first counter gives a clear time window to sequent jobs but ignores the actual remaining time of the UPS:

If there are several small power failures in a row, a server shutdown would not work with a time delay of 5 minutes if battery power is left to ensure power a maximum of 4 minutes.

The second counter is difficult to calculate and varies depending to the current load. As a consequence, there may be a time lag to execute configured tasks: 5 minutes remaining time cannot be achieved over a longer period of time, if the circumstances increase the remaining time - for example some systems will be shut down at 7 minutes remaining time. On the other hand, a predetermined Sequence of events can get mixed up as soon as the circumstances correct UPS uptime down and cause normally sequentially configured jobs simultaneously getting triggered.

**Note:**

Basically, a shutdown using remaining time is useful, since the actually existing battery charge can be included. If a special order must be observed for jobs, it makes sense to use the linearly forwarding clock for scheduling.

### Adding jobs to several events

Under circumstances, a configuration requires multiple events be assigned the same job. To assign these jobs to more than one event, it is possible to select each event individually and to define this job.

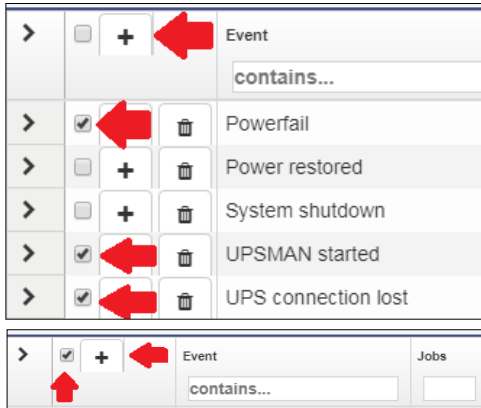

To speed up the process select the events that should receive the same job. Then click on the upper **+**.

By doing so, the same job is created inside the selected events.

Activating the checkbox at the top row will advise the CS141 to add a job is to all events. To start the job configuration dialog, click **+**.

### Delete a job

If system events are no longer used inside a configuration, administrators should remove these jobs to prevent unexpected incidents.:

- Delete a job

Open event tab by clicking **>**

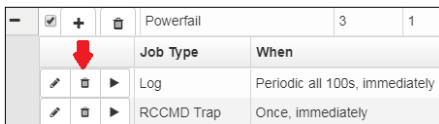

Choose the job you want to do delete and press the small trash icon. The job will be deleted immediately.

- Delete all jobs within an event

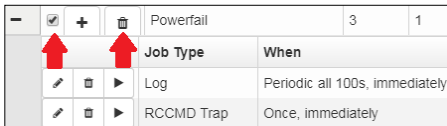

To delete all jobs inside an event, choose the checkbox of the desired event tab. Than press the small trash icon. By doing so, all jobs listed inside this event will be deleted immediately. accidentally deleted jobs need to be configured again.

### **Note:**

The CS141 allows to add, edit and delete any job. The event list itself is hard-coded and depends to the UPS you are using. Events cannot be deleted or edited by any user.

### Counter events

Some jobs must be explicitly withdrawn when an adverse event occurs:

- Information of responsible persons / "all-clears"
- Further actions
- Advised server shut downs
- ...

The configuration of a counter job follows the same pattern as the creation of a job. According to this context, for some jobs time management becomes a significant role:

Since the UPS comes back from autonomous mode to normal mode, it will take amount of time to recharge the batteries in order to run all jobs as configured.

#### *Example scenario:*

Due to a power failure the UPS has switched to autonomous mode and will hold all connected devices for 60 minutes at 100% load.

With 30 minutes remaining, many computers automatically shut down, reducing the load to 20%.

The remaining time will be corrected upwards accordingly.

Since all systems are shut down only after 5 minutes of remaining time, but the power failure at 6 minutes has been eliminated, normality returns.

In this case, the CS141 can restart all computers shut down to protect the remaining time via Wake on LAN (WOL) - this absolutely useful for automated restart of networks after power failure.

In this scenario, if all connected computers were to be restarted automatically, this means that the UPS could withstand 20% load for 6 minutes at the next power failure - but 100% load must be delivered. Since this cannot work, the WOL packet must be delayed in time to give the UPS the ability to charge a minimum of batteries.

**Note:**

It is possible to create up to 50 jobs per event. In some cases, individual jobs may contradict each other or undo desired jobs accidentally by using counter jobs.

**Custom Thresholds**

For this configuration step, proceed to the following menus:

- Devices	→ System tab: Devices
⚙️ Setup	
- UPS	→ System menu: UPS
⚙️ Setup	
🔔 Events	→ <b>Event handling configuration dialog</b>
🔧 Functions	
⚠️ Custom Thresholds	→ <b>Custom defined system event configuration dialog</b>

In some cases, UPS models allow you to customize the limits for some UPS-specific events.

The CS141 supports these features if the UPS provides such an option. Otherwise you will be informed by a corresponding system message.

The configuration is done via two menus:

- *Custom Thresholds* to define and customize settings
- *vent* menu to assign jobs

		Min	Max
<input type="checkbox"/> Battery Voltage	out of range	0 V	0 V
<input type="checkbox"/> Input voltage P-N	out of range	0 V	0 V
<input type="checkbox"/> UPS Temperature	out of range	0 °C	0 °C
<input type="checkbox"/> UPS Autonomy	less than	0 m	
<input type="checkbox"/> Battery Charge	less than	0 %	
<input type="checkbox"/> Output Load	greater than	0 %	
<input type="checkbox"/> Battery Symmetry Pos./Neg.	greater than	0 V	
<input type="checkbox"/> Seconds on Battery	greater than	0 s	

>	+	-	Battery voltage Threshold Warning Low On
>	+	-	Battery voltage Threshold Warning Low Off
>	+	-	Battery voltage Threshold Warning High On

Differences between Warning and Alarm Levels

The Custom Thresholds are identical for Warning and Alarm Levels - but they are listed separately in the UPS event menu. Furthermore, they will be listed inside log files as a Warning or Alarm.

This will allow to configure warning and alarm behavior containing different values.

These conditions can be set up:

- out of range** the event – regardless of alarm or warning - is triggered if the measured value falls below or exceeds entered values.
- less than** the event - regardless of alarm or warning - is triggered if the measured value falls below configured values.
- greater than** the event - regardless of alarm or warning - is triggered if measured value exceeds configured values.

Example: How to configure UPS temperature Custom Thresholds

Electrical devices operate safely between a minimum and a maximum temperature grade. Running a device exceeding these conditions may cause issues. These issues may vary starting from simple defects up to acute fire hazards.

In order to be able to intervene in time, therefore, a predetermined temperature value must be compared with the measured temperatures.

As an example, the manufacturer of a device specifies the "safe operating temperature" between + 5 ° C and + 39 ° C:

The CS141 can configured to warn if these values will be exceeded - the condition out of range first defines the safe temperature range.



As mentioned, two menus are required to configure Custom Thresholds:

- Custom Thresholds:

The first setting is made under Custom Thresholds where the appropriate values are set.

Warning Levels			
		Min	Max
<input type="checkbox"/> Battery Voltage	out of range	0 V	0 V
<input type="checkbox"/> Input voltage P-N	out of range	0 V	0 V
<input checked="" type="checkbox"/> UPS Temperature	out of range	10 °C	34 °C
<input type="checkbox"/> UPS Autonomy	less than	0 m	

Enabling the checkbox UPS Temperature will include measuring values according to the UPS. For the argument out of range you need to specify both - the lowest temperature value and the highest temperature value.

**Note:**

Since this is the warning, it should be sent before reaching critical values.

Due to the fact the minimum of + 5 ° C and a maximum of + 39 ° C is predefined by manufacturer, the values for warning levels must be corrected accordingly. In this example the decision is made to use 5°C:

Min: 10°C  
Max: 34°C

Save your entries and move to the next menu:

- USP events

Search for temperature threshold entries to be found at UPS events. Unlike the Custom Thresholds menu, each Threshold is displayed as regular system events and shows all possible states:

>	<input type="checkbox"/>	+	🗑️	UPS Temperature Threshold Warning Low On	1	1	0	0	0
>	<input type="checkbox"/>	+	🗑️	UPS Temperature Threshold Warning Low Off	1	1	0	0	0
>	<input type="checkbox"/>	+	🗑️	UPS Temperature Threshold Warning High On	1	1	0	0	0
>	<input type="checkbox"/>	+	🗑️	UPS Temperature Threshold Warning High Off	1	1	0	0	0

Since Custom Thresholds can be configured like regular UPS events, all jobs are available. If necessary, counter jobs can be defined according to temperature.

*Setting up Alarm Levels*

The alarm levels represent an escalation level and, if necessary, should trigger emergency measures, the values must be adjusted accordingly to warning levels.

>	<input type="checkbox"/>	+	🗑️	UPS Temperature Threshold Alarm Low On	1	1	0	0	0
>	<input type="checkbox"/>	+	🗑️	UPS Temperature Threshold Alarm Low Off	1	1	0	0	0
>	<input type="checkbox"/>	+	🗑️	UPS Temperature Threshold Alarm High On	1	1	0	0	0
>	<input type="checkbox"/>	+	🗑️	UPS Temperature Threshold Alarm High Off	1	1	0	0	0

Please note, since the condition for an alarm is fulfilled in addition to existing warning levels, configured jobs can be executed in parallel, overlap or even contradict or cancel each other out.

Exemplary excerpt: Custom Thresholds

This excerpt is an example. Depending on UPS model and manufacturer, this list will vary in naming as well as functionality differs. The sample list shown below shows the custom threshold list of a XANTO 2000R from the manufacturer Online:

		Min		Max	
<input type="checkbox"/> Battery Voltage	out of range	0	V	0	V
<input type="checkbox"/> Input voltage P-N	out of range	0	V	0	V
<input type="checkbox"/> UPS Temperature	out of range	0	°C	0	°C
<input type="checkbox"/> UPS Autonomy	less than	0	m		
<input type="checkbox"/> Battery Charge	less than	0	%		
<input type="checkbox"/> Output Load	less than	0	%		
<input type="checkbox"/> Battery Symmetry Pos./Neg.	greater than	0	V		
<input type="checkbox"/> Seconds on Battery	greater than	0	s		

Battery Voltage *out of range* XX V – XX V

Batteries are sensitive to voltages, high voltages and deep discharges can permanently damage them. This value can be used to warn in good time as the entered range is left.

Input voltage P-N *out of range* XX V – XX V

on request some UPS systems offer on measurement data of the input voltage. This value can be used to implement an alarm response to voltage dips or overvoltage on main power input

UPS Temperature *out of range* XX°C – XX °C

Some UPS systems provide internal temperature sensors to measure device temperature values. This value can be used to define an additional alarm behavior based on the temperature values that the UPS supplies.

UPS Autonomy *less than* XX m

in some cases, it may be useful to define additional alarm behavior about the remaining time a UPS ensure emergency power in autonomous mode - as an example if defined jobs depends on a configured time delay and due to several short power outages in a row Time is available: An emergency behavior scenario could be an alarm shutdown of systems.

Battery Charge *less than* XX %

If a UPS comes back from autonomous operation to normal mode, it will automatically start to recharge the batteries. This may last some time. In case of several short power failures in sequence, an additional early warning behavior can be defined using this value.

Output Load *less than* XX %

Some UPS systems provide real-time measurements of the current load. In case of the UPS switches to autonomy mode, normally non-vital systems will be shut down as soon as possible. Due to the fact the output load differs if systems will be shut down, this value can be useful for confirmation or advisory behavior.

Battery Symmetry Pos./Neg. *greater than*

Some UPS systems use the positive and the negative half wave of AC to charge batteries. This setting defines the alarm behavior if the positive battery string and the negative battery string are not loaded evenly.

Seconds on Battery *greater than* XX s

in some cases, a voltage drop is recorded, for example in case of large industrial plants are put into operation. In some cases, it may happen that a UPS switches to autonomous mode for one or several seconds. With this value an additional warning could be realized to verify a "genuine autonomy case".

**Note:**

Pay close attention to the arguments associated with the thresholds:

*Greater than, less than, in range, out of range* - since arguments are taken literally as a condition, the warning and alarm behavior will be done according to the configuration:

As an example, if the output load warning is less than 67%, it will also issue a warning if it drops to 43%. On the other hand, 67% will not warn due to the fact the value has to be below 67%

## Tutorial: Custom Thresholds

### Problem description

Although the CS141 recognizes the UPS correctly, contactors are to be activated via potential-free contacts. This shall switch off external devices as soon as the charge of the batteries drops below a configured value.

### This configuration can be realized indirectly:

If a CON\_R\_AUX4 is connected to CS141, the potential-free outputs can be used to control the contactors - it is possible to switch through (ON) and block (OFF). This will allow to implement the control of the contactors without tricky issues.

It will be difficult if the UPS does not offer suitable events:

As a consequence, these events are not displayed inside the UPS event menu. Using Custom Thresholds will allow this configuration:

The key to this configuration is the fact this function depicts a user definable job as a UPS event:

Setting 71% for Warning Levels and 61% for Alarm Levels, you can subsequently assign appropriate behavior in the UPS events:

- if the battery charge drops to 70%, the first devices are switched off.
- If the battery charge drops to 60%, the next devices are turned off. The counter events are set to Warning OFF or Alarm Off.

As the batteries are charging, the devices should start after battery charge reaches similar values for shutdown.

- From 61% the first device list will be switched on
- From 71% the second device list will be switched on.

Since there is no AND connection to the Power Fail, there are basically two possibilities to run these jobs:

1. Once
2. Repeat as long as the event is active

Note you have a difference of 1% between ON and OFF. Due to the fact the value needs to drop below the values, it is technically not possible to switch exactly ON and OFF at 70% or 60%. A decision is needed whether you wish to switch ON the devices at 60/70% or off

*You need to define your jobs exactly.*

Turning off the same devices 70% and to on position at 61% could cause conflicts between events and jobs, devices should therefore be consistently configured separately

### What will happen between 0% – 71%

Depending on the configuration, independent to any power fail the devices will stay off, shutdown or restart between 0% and 71% battery charge. Above 71% the devices will run as long as no power fail will cause the battery charge to drop at 70%. Since the current load has no influence on the percentage of battery load, the flexible remaining time does not affect this setting. The percentages of the current battery charge are basically used.

The screenshot shows two configuration panels: 'Warning Levels' and 'Alarm Levels'. Both panels have a list of parameters with checkboxes, dropdown menus for comparison operators, and input fields for minimum and maximum values. In both panels, the 'Battery Charge' parameter is checked and its configuration (operator: 'less than', value: '0', unit: '%') is highlighted with a red rectangular box. Other parameters include Battery Voltage, Input voltage P-N, UPS Temperature, UPS Autonomy, Output Load, Battery Symmetry Pos./Neg., and Seconds on Battery. At the bottom of the interface, there are 'Apply' and 'Cancel' buttons.

### **Note:**

A detailed description of the CON\_R\_AUX4 can be found at chapter *Sensors*

## CS141 as RCCMD Server device

### Ever heard something about RCCMD?

RCCMD (Remote Console Command) is the world's most successful shutdown solution for heterogeneous networks and is the best method to ensure initiating multiple messages and shutdown sequences. The solution integrates even the UPS to set up an all-in-one monitoring and messaging solution:

The RCCMD clients listen on port 6003 for incoming messages of RCCMD server module. This module is a general part of

- UPSMAN software
- CS121
- CS141
- RCCMD licensed UPS manager.

An RCCMD server controls the RCCMD clients inside networks. The functional scope ranges from monitoring, notifications up to a structured shutdown of a multiple server environment. RCCMD even considers mutual dependencies.

#### **Note:**

The RCCMD client is not freeware

A separate license is available and can be obtained worldwide from licensed resellers, OEM partners or directly ordered at [www.generex.de](http://www.generex.de).

The license itself is unlimited valid, the service scope includes 2 years of free updates from the date of purchase.

### Available RCCMD commands for the CS141

As mentioned, CS141 provides an RCCMD server.

The RCCMD commands are defined as jobs via the system events. There are four different categories available:

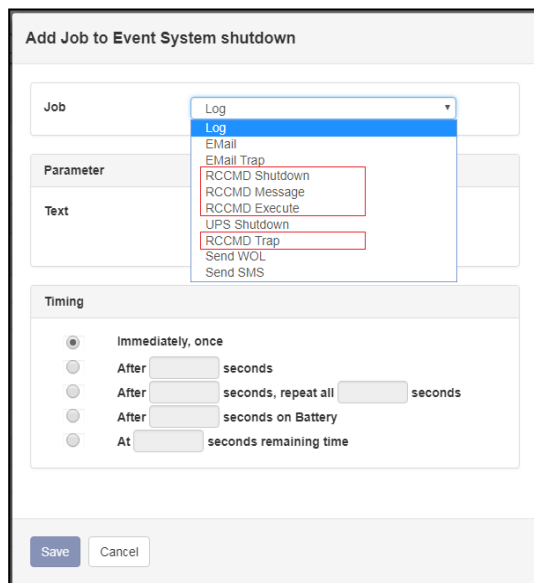

#### → RCCMD Shutdown

The RCCMD shutdown sends a signal to an RCCMD client. The RCCMD client advice the server to initiate the shutdown sequence.

#### → RCCMD Message

An RCCMD message is a notification text that can be sent to an RCCMD receiver. This text will be displayed on the screen using a separate message box.

#### → RCCMD Execute

If scripts have to be executed in advance for a shutdown, they can be triggered by using the execute command. RCCMD offers not only ready-made commands but also the possibility to start own scripts.

#### → RCCMD Trap

Trap messages are pure informational messages that can be sent to RCCMD clients. The client receives these text messages and displays them inside a pop-up message box.

#### **Note:**

An initiated RCCMD shutdown cannot be withdrawn. However, within the RCCMD client, you can also define so-called redundancies and limit IP addresses that are authorized to send an RCCMD signals. By doing so, as an example, two UPSs need to advice a server shutdown. In this case the RCCMD execute *wakeup* will withdraw a server shutdown command.

Configure an RCCMD-Job

RCCMD uses IP addressing to communicate within a network as well as a single network segment.

the following parameters can be adjusted:

→ Job selection

→ Send Broadcast messages

→ IP address of a client

→ Configured port to be used

→ Job timing

→ Save settings/ abort configuration

Set up IP address for RCCMD

*Broadcast messages*

Activating this checkbox will trigger an RCCMD broadcast job will be sent. Each RCCMD client installed in this network segment is addressed and responds by shutting down and turning off the computer. There is no distinction between host, virtual machine, single server or workstation.

*Limiting IP addressing*

A broadcast message is not always the best method for shutting down networks...

To address a particular machine within your network, enter the IP address of the device. In fact, only addressed computer - physically or virtual devices - will receive the RCCMD message.

The CS141 provides both:

creating a single job for each RCCMD client as well as combining several IP addresses to create a device group job.

... One job, one IP address ...

... several IP-addresses to configure a group job.

For several IP addresses, please ensure the correct syntax:

192.168.3.1,192.168.3.18, ...

The IP addresses will be written without space between the individual entries. Otherwise you will receive a corresponding error message.

**Note:**

Broadcast messages and individual IP addressed or collective addressed messages are mutually exclusive: You can configure the RCCMD client to accept commands by single IP addresses. But the client cannot be configured to differ between a broadcast message and a single message. If you want to shut down devices and device groups first and then send a broadcast, you need to create several jobs with a corresponding time delay.

*Port selection*

As a default port, RCCMD uses port 6003. The RCCMD client is listening on this port for a valid RCCMD command.

If your RCCMD client has been assigned a different port during installation and configuration, ensure sender and receiver are using the same ports.

The screenshot shows a configuration window with a title bar 'Parameter'. Below the title bar, there is a 'Broadcast' checkbox which is checked. Underneath, there are two input fields: the first is labeled 'IP' and contains the text '192.168.3.1'; the second is labeled 'Port' and contains the text '6003'.

RCCMD Job Timing

The CS141 provides many system events a job can be assigned to. Some jobs allow to configure advanced timing:

The screenshot shows a configuration window titled 'Timing'. It contains five radio button options, each with a corresponding text label and some with input fields: 1. 'Immediately, once' (selected). 2. 'After [ ] seconds'. 3. 'After [ ] seconds, repeat all [ ] seconds'. 4. 'After [ ] seconds on Battery'. 5. 'At [ ] seconds remaining time'.

- Immediately, once                      as soon as an event happens, this job is executed at once and not repeated.
- After XXX seconds:                      The CS141 will wait a pre-defined time in seconds and then execute the job. If the event is no longer active before time is up, the job will not be executed.
- Repeat all XXX seconds:                      The job is repeated cyclically until the event no longer is no longer active.
- After XXX seconds on battery:                      The event forces the UPS will to switch to autonomous mode. The job will be executed if the UPS remains a pre-defined time in this state. For example, if 300 seconds are set, this job will only be executed if the UPS operates in autonomous reaches 300 seconds.
- At XXX seconds remaining time:                      The job is executed when the remaining UPS operating time is reached or undershot. Note based on the current load this time value becomes flexible

RCCMD command

*Der RCCMD Shutdown*

The screenshot shows a configuration window with a title bar 'Parameter'. Below the title bar, there is a 'Broadcast' checkbox which is checked. Underneath, there are two input fields: the first is labeled 'IP' and contains the text '192.168.3.1'; the second is labeled 'Port' and contains the text '6003'.

The RCCMD shutdown is predefined and advises the addressed RCCMD client to shut down the operating system and turn off the device. Adjustable options include broadcast, sending to individual IP addresses and the port used for RCCMD.

## The RCCMD Message

Parameter	
Text	<input type="text" value="Am Brunnen, vor dem Tore, da steht ein..."/>
IP	<input type="checkbox"/> <b>Broadcast</b> <input type="text" value="192.168.3.15"/>
Port	<input type="text" value="6003"/>

The RCCMD message is a text message that can be defined freely. The text box automatically shifts with the entered text as soon as you reach the right margin. This message will then appear as an alert on a computer the RCCMD client is installed to. RCCMD also displays a warning box on the taskbar.

### RCCMD Executes

Parameter	
IP	<input type="checkbox"/> <b>Broadcast</b> <input type="text" value="192.168.3.1"/>
Port	<input type="text" value="6003"/>
Command	<input type="text" value="helloworld.bat"/>

An extensive feature within RCCMD is the possibility to run own executables and batch files on a target computer.

This function is useful if scripts have to be executed right before a shutdown is triggered. It is necessary to move the file to be executed to the installation directory of the RCCMD client. Afterwards, the CS141 provides to execute this script directly.

### Note:

The screenshot shows the command helloworld.bat has been entered. In this case, the RCCMD client on the PC with the IP address 192.168.3.1 would try to start the file helloworld.bat directly. If you want to use other directories, you need to specify them accordingly:

C:\skript\helloworld.bat

Please note, it is tricky to run a script on a PC that shall trigger scripts on a third device.

## RCCMD Traps

RCCMD traps are data packets designed to inform about the current state of the UPS:

A data package is generated, which can be received, read out and interpreted by a corresponding software or device.

The following list contains possible variables that you can use to define RCCMD traps:

#AGENTSOFTRREV	CS141 Firmware Version
#AUTONOMTIME	autonomy time in minutes
#BATT2OLD()	time in months until event „Please check batteries“ is triggered
#BATT2OLD_YEARS	battery age in years
#BATTCAP	battery capacity in %
#BATTINSTDATE	installation date of the battery
#BATTTESTDATE	date of the last battery test
#BATTVOLT	battery voltage in V
#CHARGECCURR	momentary loading current
#CNT_BL	counter battery low
#CNT_PF	counter Powerfail
#CNT_SA	counter active shutdowns
#CNT_SD	counter shutdowns
#CNT_TF	counter testing failure
#DATE	current date
#EVENTSTATE	obstatus (idle, error, progress, success)
#FULLTESTDATE	date of the last full battery test
#GETLASTRESULT()	last test results
#HOLDTIME	hold time at 100 % load
#IDENT_NAME	name of the SNMP adapter
#INCURR0/1/2	Eingangsstrom in A
#INFREQ0/1/2	Eingangsfrequenz in Hz
#INPHASES	Anzahl Eingangsphasen
#INPUTCURRENT0/1/2	incoming current in A
#INVOLT0/1/2	incoming voltage in V
#LASTERR	last error
#LOAD	current load
#LOCATION	Standort
#MANUFACTURER	manufacturer of the UPS
#MODEL	UPS model
#OUTFREQ0/1/2	Ausgangsfrequenz in Hz

#OUTPHASES	Anzahl Ausgangsphasen
#OUTPOWER0/1/2	Last in Prozent
#OUTPUT_VOLT0/1/2	
#OUTPUTCURRENT0/1/2	
#OVERLOAD	overload
#PHASES	phases
#POWER	power of the UPS
#RECHARGETIME	time needed for a full recharge of batteries
#RESTORETIME	restore time
#RUNTIME	uptime since last commissioning
#SECONBAT()	seconds on battery
#SELFTESTDATE	date of the last self test
#SERVER	IP address of the SNMP manager
#STATUS	system state
#SYSDATE()	system date
#SYSTEMTIME()	system time
#TEMPDEG	temperature in °Celsius
#TIMEZONE	time zone
#VOLTAVAI	USV bezogen, // USV hat eine Möglichkeit, die Inputvoltage abzufragen

**Sensors and devices**

For this configuration step, navigate to the following menu items:



Depending on used model, the CS141 offers to connect external sensors and devices sensors. These CS141 models support the connection of sensors:

- CS141 SC
- CS141 L
- CS141 R2
- CS141 Mini

SM T H COM Standalone Sensor

This example shows how to configure the SMT\_H\_COM standalone sensor, a combined temperature and relative humidity sensor available for CS141.

The supplied standard length of the cable to connect the sensor to CS141 is 1.8 meters. If required, cable length up to 30m can be used.

Wiring the external sensor

Connect CS141 COM 2 to SM\_T\_H\_COM. CS141 does not require to reboot.



Basic Setup Configuration

Under Devices / Setup, go to Configuration and change the setting at COM2 from none to Sensor.

After changing, define type of sensor connected to CS 141.

In this case, select SM\_T\_H\_COM:

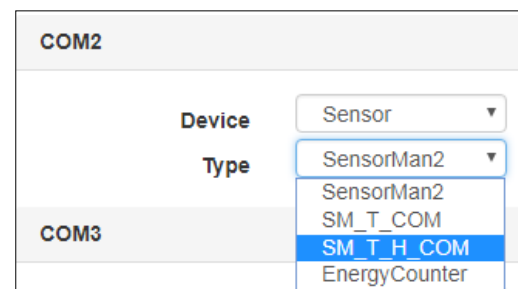
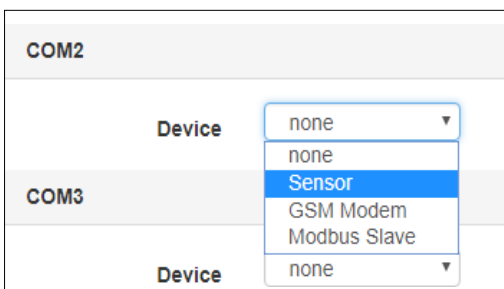



Press *Apply* to start the corresponding service. The status bar indicates the process.

<b>UPS:</b> <span style="color: green;">●</span> OK <b>Sensor:</b> <span style="color: yellow;">●</span> Restarting
--

While Sensor is restarting, the according menus will be prepared. Please wait until the Sensor mark is set to "OK" before entering the configuration dialog of the sensor.

Configuration of zhe SM\_T\_H\_COM combi sensor

Under the main tab *Devices*, open the sub menu *Sensors* and click on *Setup*. This will open the *Sensor configuration dialog*.

Name	Unit	Low PreAlarm	Low Alarm	High PreAlarm	High Alarm	Offset
Channel 1	°C ▼	10 <input type="checkbox"/>	5 <input type="checkbox"/>	80 <input type="checkbox"/>	90 <input type="checkbox"/>	0
water melon tank	% rel H	10 <input type="checkbox"/>	5 <input type="checkbox"/>	80 <input type="checkbox"/>	90 <input type="checkbox"/>	0

**Name**

**Name**

At Name, enter the name, a description or an installation place of the sensor. The Name will appear at the sensor monitoring screen.

Thresholds Low / High und Alarm functions

The SM\_T\_H\_COM combined sensor provides two different sensor types. The temperature sensor operates between -25 °C and +100 °C. The humidity sensor measures humidity range 0% and 100%. After installing the sensor, the maximum sensor range will be shown without a range restriction or notification markers. In order to define an alarm behavior, the CS141 needs information about the critical values and if necessary, a configured measuring range.

Low PreAlarm	Low Alarm	High PreAlarm	High Alarm
7 <input type="checkbox"/>	5 <input type="checkbox"/>	60 <input type="checkbox"/>	80 <input checked="" type="checkbox"/>
0 <input type="checkbox"/>	0 <input type="checkbox"/>	249 <input type="checkbox"/>	135 <input type="checkbox"/>

Please note the following rules during configuration:

1. The pre-alarm must be lower than the critical alarm setting.
2. The relative humidity is a minimum of 0% and a maximum of 100%
3. The coldest temperature value is -25 °C and the highest value + 100 °C

**Note:**

As long as the checkboxes for the according alarm is not set, the respective alarm marker. Due to this fact it is possible to configure notification and alarm values and test the settings before activating.

Offset - Settings

**Offset**

Although the SM\_T\_H\_COM is already a calibrated sensor, the operating environment may require different values. The correction values will be defined via offset settings:

These values will be added or subtracted from the value the sensor provide. This allow to harmonize the sensor values with callibrated external measurings and to adapt the sensor for special operating conditions.

Sensor-related system events

The CS141 provides defining system jobs via connected sensors. The available system events refer to the measured values of the connected sensors. The following events are available for SM\_T\_H\_COM.

*SM\_T\_H\_COM Temperature High*

The value at Threshold (high) defines the upper critical temperature limit. If this temperature is exceeded, a corresponding alarm behavior can be triggered.

*SM\_T\_H\_COM Temperature Low*

The value Threshold (low) defines the lower critical temperature limit. If this temperature is undershot, a corresponding alarm behavior can be triggered.

#### *SM\_T\_H\_COM Temperature Normal*

Defined by the values for the upper and lower temperature limits. If no limits are entered, any displayed temperature will be displayed as "normal".

#### *SM\_T\_H\_COM Humidity High*

The value is defined by Threshold (high) for the relative humidity and determines the upper critical limit for humidity. If this value is exceeded, a corresponding alarm behavior can be triggered.

#### *SM\_T\_H\_COM Humidity Low*

The value is defined via Threshold (low) for the relative humidity and determines the lower critical limit for humidity. If this value is undershot, a corresponding alarm behavior can be triggered.

#### *SM\_T\_H\_COM Humidity Normal*

Defined by the values for the upper and lower relative humidity. If no limits are entered, any displayed humidity will be displayed as "normal".

#### *SM\_T\_H\_COM Connection Lost*

If the connection between the CS141 and the SM\_T\_H\_COM tears off, a corresponding alarm behavior can be triggered via this system event.

#### *SM\_T\_H\_COM Connection Restored*

The counter event to Connection Lost: The connection has been restored; a corresponding alarm behavior can be triggered via this system event.

### Event classification

At the sub menu Sensors, click on the menu Events:

All sensor events use the same event classification:

- Temperature / Humidity High
- Temperature / Humidity HighPreAlarm
- Temperature / Humidity normal
- Temperature / Humidity LowPreAlarm
- Temperature / Humidity Low

Click  $\triangleright$  to open the general job list. With  $\oplus$ , the job configuration dialog will be triggered to add a new job to the current job list.

				SM_T_H_COM Temperature High	1	1	0	0
		<b>Job Typ</b>		<b>Wann</b>	<b>Parameter</b>			
			Log	Einmal, sofort	{ "text": "SM_T_H_COM Temperature High" }			

### **Note:**

For detailed informationen about how to manage jobs, refer the following chapter: [Managing jobs](#)

Assign a counter job

Please note that, depending on the configuration, some executable jobs require a so-called counter job, while other jobs simply no longer need to be executed because the event is no longer pending. This job is configured by triggering it when the corresponding new event occurs - e.g. the contact is automatically closed when temperature high is reached and opened again as a counter event at normal temperature. Meanwhile, a mail notification will be sent every 5 minutes as long as the Temperature High event is pending. Do not confuse a counter-event with a counter-job at this point - one is an event that is pending, the other the corresponding job that is to be triggered for an event - both are relative to each other.

### Monitor sensors: Check configuration

For this screen, open the following menu:

Once completed all settings, the sensor data will be shown at Sensor Monitor:

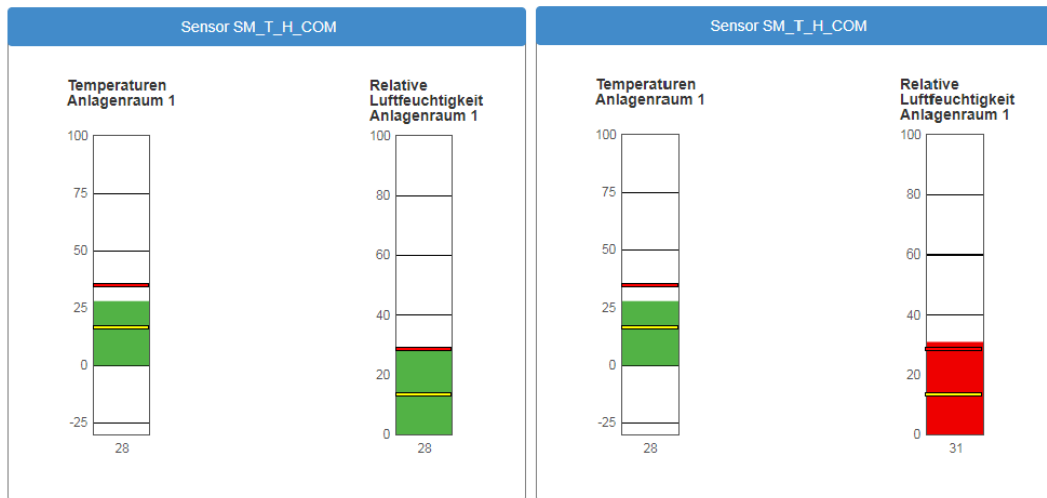

The yellow line represents the value of the Threshold (low). The upper line represents the Threshold (high). As soon as the value exceeds or falls below these lines, the color changes to red and a corresponding job can be triggered for the according sensor event. If you use pre-alarms and alarm settings, the Sensor monitor will show the according marker.

**Tipp:**

Sollten Sie mehrere Sensoren benötigen, bietet der CS141 über den Sensormanager die Möglichkeit, bis zu 8 Umweltkontrollsensoren zu betreiben.

Die genaue Konfiguration entnehmen Sie bitte der Installations- und Konfigurationsanleitung des SENSORMANAGERS, welche Sie unter [www.generex.de](http://www.generex.de) im Downloadbereich erhalten können.

## SENSORMANAGER

The SENSOR MANAGER is an optional accessory to extend the functionality of the CS141:

The EXPONENTIAL POWER sensors / actuators can easily be connected to the SENSOR MANAGER, required RJ12 connection cables are included on delivery. The sensor can be configured via the web interface of the CS141 / EQUALINKWEBMANAGER. Any third-party sensor or actuator that conform with required specifications, can be used with the SENSORMANAGER.

### SENSORMANAGER II application examples:

#### *Monitoring of sensor data*

Temperature, humidity, electr.. Electricity, electr. Voltage, electr. performance and other analogue measurements.

#### *Monitoring of contacts:*

Door contacts, fire detectors, motion detectors, water detectors, glass breakage sensors and other potential-free signaling contacts.

#### *Switching:*

Switching of optical and acoustic actuators such as flashing lights, warning horns u. relay contacts

### SENSORMANAGER II input signals:

Up to 8 analog inputs (0-10VDC o. 0 / 4-20mA)

Up to 4 digital inputs (potential-free contacts)

### SENSORMANAGER II output signals:

Up to 4 digital output signals (open collector / 12VDC max 30mA)

### SENSORMANAGER II PIN assignment of the RJ12 connection sockets

#### INPUT 1:

Pin 1	9-24VDC, output according to input of supply voltage, default delivery: 12VDC power supply
Pin 2	Analog input channel 1 (0-10VDC o. 0/4-20mA)
Pin 3	Analog input channel 2 (0-10VDC o. 0/4-20mA)
Pin 4	Ground (GND)
Pin 5	Digital output (Open-Collector 9-24VDC/max. 30mA, Default on delivery: 12VDC)
Pin 6	Digital input (min./max. 9-24V via Pin 1)

#### INPUT 2:

Pin 1	9-24VDC, output according to input of supply voltage, default delivery: 12VDC power supply
Pin 2	Analog input channel 3 (0-10VDC o. 0/4-20mA)
Pin 3	Analog input channel 4 (0-10VDC o. 0/4-20mA)
Pin 4	Ground (GND)
Pin 5	Digital output (Open-Collector 9-24VDC/max. 30mA, Default on delivery: 12VDC)
Pin 6	Digital output (min./max. 9-24V via Pin 1)

#### INPUT 3:

Pin 1	9-24VDC, output according to input of supply voltage, default delivery: 12VDC power supply
Pin 2	Analog input channel 5 (0-10VDC o. 0/4-20mA)
Pin 3	Analog input channel 6 (0-10VDC o. 0/4-20mA)
Pin 4	Ground (GND)
Pin 5	Digital output (Open-Collector 9-24VDC/max. 30mA, default on delivery: 12VDC)
Pin 6	Digital input (min./max. 9-24V via Pin 1)

#### INPUT 4:

Pin 1	9-24VDC, output according to input of supply voltage, default delivery: 12VDC power supply
Pin 2	Analog input channel 7 (0-10VDC o. 0/4-20mA)
Pin 3	Analog input channel 8 (0-10VDC o. 0/4-20mA)
Pin 4	Masse (GND)
Pin 5	Digital output (Open-Collector 9-24VDC/max. 30mA, Default on delivery: 12VDC)
Pin 6	Digital input (min./max. 9-24V via Pin 1)



Pin number:	Funktion:
1	9-24VDC, output according to input of supply voltage, default delivery: 12VDC power supply
2	Analog input channel x (0-10VDC o. 0/4-20mA)
3	Analog input channel x (0-10VDC o. 0/4-20mA)
4	Ground (GND)
5	Digital output (Open-Collector 9-24VDC/max. 30mA, Default on delivery: 12VDC )
6	Digitalinput (min./max. 9-24V via Pin 1)

**Note:**

The voltage provided by pin 1, pin 5 and pin 6 is defined by the power supply unit used on the SENSOR MANAGER. The SENSOR MANAGER itself operates at an operating voltage of 9-24V. If a 12 V power supply is connected, 12 VDC will be offered on these pins accordingly. When connecting external devices, pay attention to the maximum permissible voltage that may be applied:

Overvoltage can damage or even destroy connected devices. In case of undervoltage, however, connected devices may deliver wrong results.

On delivery the SENSOR MANAGER comes with a standard power supply providing 12 VDC.

**Analog inputs:**

Each of the 4 SENSORMANAGER\_II physical RJ-12 connectors provide 2 analog inputs on pin 2 and pin 3.

Administrators wishing to connect a third-party device, must set the signal (0-10VDC o. 0 / 4-20mA) of the third-party device to PIN 2 or pin 3 and pin 4 (ground / GRD).

**Digital inputs:**

Each of the 4 physical RJ-12 connections of the SENSORMANAGER\_II provides a digital input on pin 6.

For Administrators who wish to connect a third-party device:

The high signal (12VDC) from pin 1 must be routed to pin 6 via the signaling contact of the third-party device.

**Digital outputs:**

Each of the SENSORMANAGER's 4 physical RJ-12 ports provides a digital output on pin 5.

Administrators who wish to connect a third-party device:

The device must be connected to pin 5 (open collector output: + 12VDC / max.30mA) and pin 4 (Ground / GND) are connected.

**Note:**

**How to use third-party sensors**

Due to the fact third-party devices do not have the standardized RJ12 port, our Connection Terminal SM\_CON is an easy-to-use possibility to connect these devices to the CS141. By using the SM\_CON it is possible to adapt open line ends to the Rj12 connector directly - No custom plug

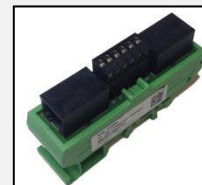

Connecting sensors / actuators to the SENSORMANAGER II

The sensors / actuators for the SENSORMANAGER II can be connected directly to the SENSORMANAGER II RJ12 sockets- ensure to use the original RJ12 cables supplied with the according sensor.

The SENSORMANAGER II provides to connect several sensors / actuators to one physical port. The system design provides following wiring options:

1. A maximum of two analog sensors per port
2. A maximum of one more digital sensor per port
3. A maximum of one digital actuator per port

The sensor manager supports a total installation of 8 analog and 4 digital sensors as well as up to 4 digital actuators.

Sensor connection scenarios: SENSORMANAGER II.

The SENSORMANAGER II provides various options to connect sensors.

The Daisy Chain: Connection

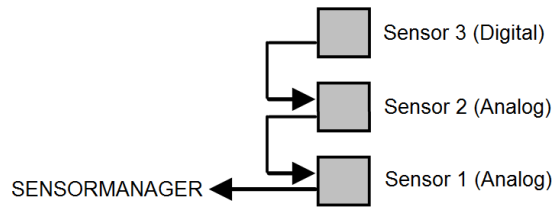

The daisy chain is a sequential arrangement of sensors and actuators. The signal is transmitted from the sensor manager through the first sensor to the second sensor. In this installation example, a digital third sensor is attached to the second sensor. Please note that no further digital sensor can be attached to the sensor 3.

The Splitting Plug SPSMRJ connection

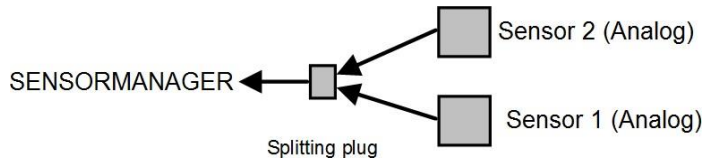

If sensors need to be installed in different areas, the signal distribution can be split into two wirings. The optional splitting plug will split the signal accordingly. Please note that the sensor manager can only serve two analog sensors per port.

Combined connections: Daisy Chain and Splitting Plug SPSMRJ

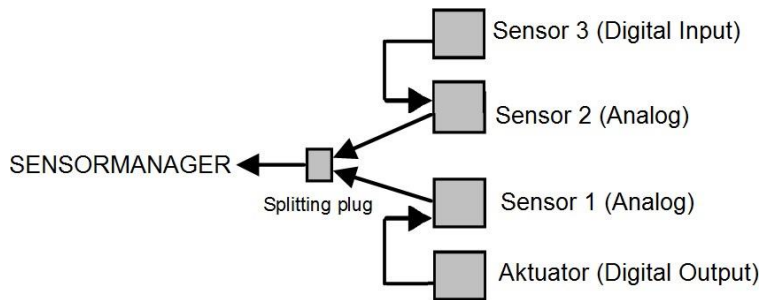

This installation constellation extends the existing installation by an actuator and a digital sensor: The port on the sensor manager is maxed out utilizing a total of 4 devices: Please note the system design:

This installation design provides the maximum of two analog sensors and one digital sensor as well as one digital output per sensor manager port.

### SENSORMANAGER II: Available sensors

These sensors are currently available for SENSORMANAGER\_II:

#### *EXPONENTIAL POWER-Analog-Sensors:*

SM\_T (Temperature sensor -> 1 analog channel required)  
SM\_T\_H (Combined sensor: Temperature and humidity -> 2 analog channels required)  
SM\_VMC (True RMS AC voltage sensor -> 1 analog channel required)  
SM\_CSxxxA (AC- current sensor -> 1 analog channel required)

#### *EXPONENTIAL POWER-Digital-Input-Sensors*

SM\_HYG2 (water and humidity sensor -> 1 digital input required)  
SM\_Glas (Glas breach detector -> 1 digital input required)  
SM\_MD (motion detector -> 1 digital input required)  
SM\_SD (Smoke - und fire detctor -> 1 digital input required)  
SM\_DC (door contact alarm detector -> 1 digital input required)  
SM\_H2 (Hydrogen Sensor -> 2 digital inputs required)

#### *Digital EXPONENTIAL POWER-Actuators:*

SM\_IO (Ralais-Box -> 1 digital output required)  
SM\_BUZ (accustical alarm buzzer -> 1 digital output required)  
SM\_Flash (flash light -> 1 digital output required)

### SENSORMANAGER II – Installation and configuration

Before you start ...

The configuration must be saved to the PIC processor of the SENSOR MANAGER. This will be done by the CS141 automatically if pressing save buttons. If a configured SENSOR MANAGER needs to be replaced, the configuration stored in the CS141 must be written to the new PIC processor by applying again. A spare parted SENSORMANAGER will not work without writing the new configuration.

#### SENSORMANAGER II: Connecting to CS141

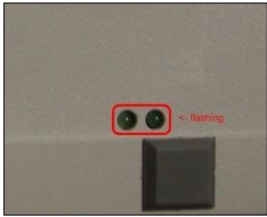

Use the supplied cable to connect the COM1 of the SENSOR MANAGER II to the COM 2 of the CS141. Log into the CS141 and go to general COM port settings. Configure the comport for sensormanager usage.

Then connect the power supply to the SENSORMANAGER:

Two LED's are installed on the underside of the SENSOR MANAGER: one should now light continuously and signal the operational readiness. The second LED flashes only when the CS141 makes a request to the SENSORMANAGER.

After the SENSORMANAGER is ready for configuration, open sensor manager configuration menu at CS141 and start configuring your sensors and devices.

#### **Note:**

The CS141 will only make a request to the SENSORMANAGER if it is configured accordingly. The LED on the sensor manager will only flash when a request has been received or is answered by the SENSORMANAGER.

Please note that the sensor manager is a stand-alone device with its own power supply. In case of main power supply is not available will cause disabling the connected sensors and actuators. The CS141 will notice this fact and can be configured to send custom alarm messages for sensor lost issues.

When using a SENSORMANAGER, ensure both, CS141 and SENSORMANAGER are secured by independent power supply (UPS) for full operability in case of main power issues.

### Sensor matrix

For this configuration step, proceed to the following menus



A special feature of the sensor manager is the possibility to link logically all available sensors and contacts via a matrix. Because the matrix does not tell you which sensors and digital inputs you want to use for linking to each other, there are numerous ways to map your operating scenario - as an example, a pressure sensor monitoring a pipe can be used with a temperature sensor on a corresponding pump in the first instance. With a second instance, different sets of sensor markers can be combined to trigger a unique alarm behavior.

#### How does the sensor matrix work?

As already described, the matrix is a link of individual instances that build on each other

1. Sensors and Inputs -> Individual single configuration and event management
2. Matrix marker -> Links logically individual sensors and digital inputs to a collective marker
3. Output switcher -> Links logically single alarm marker to switch an output

Each of these three instances has its own events, which can be assigned with jobs via the event control inside the sensor menu.:

#### Adding analog sensors

At system tab Sensors, open Setup to enter the sensor configuration dialog:

Sensor Inputs	Name	Sensortype	Unit	Low PreAlarm	Low Alarm	High PreAlarm	High Alarm	Sensor Range	Offset
1	Temperature	SM_T_H	°C	10	4	70	90	-5 - 100	
	Humidity	SM_T_H	% rel H	17	15	28	30	0 - 100	

#### Name

Enter a name or a description that will be shown at the alarm matrix as well as the sensor monitor.

#### Sensortype

Determine the type of sensor. To do this, select one of the predefined sensor types from the list. For third-party sensors, please consult the appropriate user manual to enable connection. Please note that some sensors are so-called combined sensors - two sensors in one housing. These require both channels and no further sensors can be connected.

#### Unit

With the choice of the sensor a suggestion for the indicated unit name appears. You can customize the name to your liking, but the unit that you see as a suggestion will not change itself.

#### Pre-alarm / alarm

Passen Sie an dieser Stelle die entsprechende Alarmstufe an. Dabei gilt folgendes Grundprinzip:

Adjust the appropriate alarm level. The following basic principle applies:

With increasing values on a measurement scale, the pre-alarm is BEFORE the actual alarm - at a temperature, e.g. the pre-alarm (pre-alarm) at 70 °C - the actual alarm is 90 °C. As the values decrease, the concept revolves: the pre-alarm must be higher than the actual alarm - in relative humidity, this means the pre-alarm is at 17% humidity during the actual alarm, which would be triggered at 15% relative humidity.

#### Note:

Please keep in mind, with decreasing temperatures the pre-alarm may be set with +3°C, but the actual alarm is at -5°C. From 0°C down, the numbers will start to increase with a negativ sign.



### Sensor range

Many sensors have a predefined measuring range - in other cases it makes no sense to create a measuring range outside certain operating values. With this value range, it is possible to adjust the measuring range to a custom sensor as well as to specific operating environments.

### Offset

Although all sensors are calibrated on delivery by EXPONENTIAL POWER, operating conditions may use different reference values. The values may differ as a result from changing atmospheric pressure, ambient temperatures, solar radiation, etc. Use the offset values to adjust the values to fit to a local reference measuring. Simply enter the corresponding deviation:

If e.g. If your reference reading deviates downward at a temperature of 2 ° C, enter -2 as offset value.

### Sensor event vs matrix event

Configured sensor alarms can be used to configure according event:

For each analog sensor, you will find 2 according events:

- Alarm Analog Input High -> Alarm: critical value reached or exceeded high alarm settings
- Alarm Analog Input High off -> Alarm: Critical value fell below high alarm settings
- Pre-Alarm Analog Input High -> Pre-Alarm: Questionable value reached or exceeded high pre-alarm settings
- Pre-Alarm Analog Input High off -> Pre-Alarm: Questionable value fell below high pre-alarm settings

---

- Normal state – no alarm -> No alarm configurable

---

- Pre-Alarm Analog Input Low off -> Pre-Alarm: Questionable value fell below low pre-alarm settings\*
- Pre-Alarm Analog Input Low -> Pre-Alarm: Questionable value reached or exceeded low pre-alarm settings\*
- Alarm Analog Input Low off -> Alarm: Critical value fell below low alarm settings\*
- Alarm Analog Input Low -> Alarm: critical value reached or exceeded high alarm settings \*

\*) Please note the paradox that the value can also increase with negative values (eg at temperatures in the minus range).

For each of these events, you can configure a corresponding job to setup a specific alarm behavior. Using the alarm matrix, you can summarize the corresponding events and stitch them an event marker with coming with it's own conditions.

Open the menu Matrix to find all events as checkbox list:

Sensor Inputs	Name	Sensorty
1	Temperature Area 51	SM_T_H
	Humidity in % Area 51	SM_T_H

	1	2	3	4	1	2	3	4	1	2	3	4	1	2	3	4
	<input checked="" type="checkbox"/>	<input checked="" type="checkbox"/>	<input type="checkbox"/>	<input type="checkbox"/>	<input type="checkbox"/>	<input type="checkbox"/>	<input type="checkbox"/>	<input type="checkbox"/>	<input type="checkbox"/>	<input type="checkbox"/>	<input type="checkbox"/>	<input type="checkbox"/>	<input type="checkbox"/>	<input type="checkbox"/>	<input type="checkbox"/>	<input type="checkbox"/>
<b>Sensor Input 1</b>	<input type="checkbox"/>	<input type="checkbox"/>	<input type="checkbox"/>	<input type="checkbox"/>	<input type="checkbox"/>	<input type="checkbox"/>	<input type="checkbox"/>	<input type="checkbox"/>	<input type="checkbox"/>	<input type="checkbox"/>	<input type="checkbox"/>	<input type="checkbox"/>	<input type="checkbox"/>	<input type="checkbox"/>	<input type="checkbox"/>	<input type="checkbox"/>
Temperature Area 51	<input type="checkbox"/>	<input type="checkbox"/>	<input type="checkbox"/>	<input type="checkbox"/>	<input type="checkbox"/>	<input type="checkbox"/>	<input type="checkbox"/>	<input type="checkbox"/>	<input type="checkbox"/>	<input type="checkbox"/>	<input type="checkbox"/>	<input type="checkbox"/>	<input type="checkbox"/>	<input type="checkbox"/>	<input type="checkbox"/>	<input type="checkbox"/>

At sensor configuration, you can enter a name for each channel. After entering a name press apply and change tot he menu „Matrix“: The recently entered name will it will be displayed automatically as soon as you move the mouse over the according channel checkbox.

### Setting up the logical connection

Using the logic link, the condition can be defined to set the marker to a logical On:

- And Both conditions must be
- Or At least on of the configured conditions are met.

### Inverted mode

As a standard, the marker is pre-configured to switch to ON as long as the conditions for ON are met. The inverted turn this switching behavior from OFF to ON: The marker ist always at High (ON) position and will will switch to Low (Off).

Digital inputs

In addition to analog inputs, the SENSORMANAGER can manage up to 4 digital inputs. The inputs

Diese Eingänge werden entsprechend der Konfiguration auf Aktiv geschaltet und können im Alarmverhalten als NC (Normally Closed) oder NO (Normally Open) – Kontakt definiert werden.

Input	Name	NC Contact	Active
1	hull brake aquarium 2	<input type="checkbox"/>	<input checked="" type="checkbox"/>
2	water level below 80%	<input type="checkbox"/>	<input checked="" type="checkbox"/>

Linking digital inputs

The marker only looks whether the result of the digital input is "High (On)" or "Low (Off)" - The type of contact is unimportant for the marker. like the analog inputs, name of the digital input will be shown by mouse over action. The linking of the digital inputs follows the same principle as with the sensors.

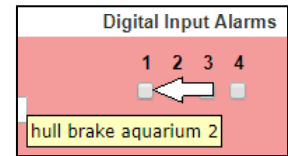

Linking digital inputs and analog sensors

Simply select the appropriate digital inputs with the analog inputs. Press Apply to save the setting and restart the services for the sensors.

Switching an output

Outputs will be switched in case of conditions met via the defined alarm markers:

SensorMan2 Digital Outputs																		
Port	Name	Logic	Marker															
1	Output 1	And ▾	<table border="1"> <tr> <td>1</td> <td>2</td> <td>3</td> </tr> <tr> <td><input checked="" type="checkbox"/></td> <td><input checked="" type="checkbox"/></td> <td><input type="checkbox"/></td> </tr> <tr> <td><input type="checkbox"/></td> <td><input type="checkbox"/></td> <td><input type="checkbox"/></td> </tr> <tr> <td><input type="checkbox"/></td> <td><input type="checkbox"/></td> <td><input type="checkbox"/></td> </tr> <tr> <td><input type="checkbox"/></td> <td><input type="checkbox"/></td> <td><input type="checkbox"/></td> </tr> </table>	1	2	3	<input checked="" type="checkbox"/>	<input checked="" type="checkbox"/>	<input type="checkbox"/>	<input type="checkbox"/>	<input type="checkbox"/>	<input type="checkbox"/>	<input type="checkbox"/>	<input type="checkbox"/>	<input type="checkbox"/>	<input type="checkbox"/>	<input type="checkbox"/>	<input type="checkbox"/>
1	2	3																
<input checked="" type="checkbox"/>	<input checked="" type="checkbox"/>	<input type="checkbox"/>																
<input type="checkbox"/>	<input type="checkbox"/>	<input type="checkbox"/>																
<input type="checkbox"/>	<input type="checkbox"/>	<input type="checkbox"/>																
<input type="checkbox"/>	<input type="checkbox"/>	<input type="checkbox"/>																
2	Output 2	Or ▾																
3	Output 3	Or ▾																
4	Output 4	Or ▾																

In contrast to the markers, however, no pre-alarms are used - if the marker is set to high, the output will be switched depending on its switching logic. The CS141 matrix provides combining up to 8 markers individually and assign them with an AND / OR combination. The output will be switched:

1. As soon as only one of the configured marker are set to high. („OR“)
2. As soon as all configured marker are in high state („AND“)

Fallback of the output to normal state

the output is only switched as long as the condition has been fulfilled exactlyhereby the corresponding logical link will decide which condition leads to the drop of the output:

In a restrictive AND operation, only one marker to off will force the output to off.

With an OR operation, the output remains at ON state until each marker is turned off.

Keep in mind that the markers conditions for an on/off state will not be checked by output switching control – This control only checks logically the markers state and act according to it.

**Tutorial: Example scenario: aquarium**

*In this simple example the cross reference between a cracked disc and a leaking aquarium will be described. It shall show you how markers, inputs and outputs will be linked and work together. The total scope of scenarios can reach very high complexity and fitted even to very custom problems....*

Huge aquariums with large glass panels are dependent on ensuring the structural integrity. If a glas panel is damaged or cracked, a

Input	Name	NC Contact	Active
1	hull breach alert aquarium 2	<input type="checkbox"/>	<input checked="" type="checkbox"/>

corresponding alarm must be issued automatically. For this purpose, the sensor manager offers a digital input:

The method this crack sensor uses to detect a cracked glass is a secondary question as the SENSOR MANAGER also supports the connection of third-party sensors. If necessary, connect an additional relay box to each sensor manager input: With the SM\_IO box, managing all 4 inputs and outputs is made intuitive.

In this scenario, a glass crack sensor would close a switch and thus report a problem to digital input 1.

The second essential value is the water level of our aquarium, which requires intervention drops below a certain amount of water. In this case, a level sensor is used, which closes a digital contact at a filling level of 80%:

2	<input type="text" value="water level below 80%"/>	<input type="checkbox"/>	<input checked="" type="checkbox"/>
---	--	--------------------------	-------------------------------------

This input clearly indicates that the water level has dropped, but not why it happened - normally this will be caused by natural evaporation.

*The cross reference:*

Using the matrix, you can now handle both events in conjunction to each other:

<b>Marker 1</b>	<input type="checkbox"/>	And ▼	1	2	3	4
			<input checked="" type="checkbox"/>	<input checked="" type="checkbox"/>	<input type="checkbox"/>	<input type="checkbox"/>

In this case, marker 1 would be set active if both inputs are closed at the same time: The idea is that a glass crack alarm is present AND the level has dropped below 80% - in this case someone should be informed at once.

In the Events menu, fsearch for Alarm Marker 1:

In diesem Beispiel soll eine SMS geschrieben werden, sobald beide Bedingungen erfüllt sind:

In this example, an SMS should be sent as soon as both conditions are met:

At the moment the marker is activated, the CS141 will issue an emergency SMS if a GSM modem or alternatively an IP modem is available. Thus, both individual input events have been directly connected, other jobs are possible that will be repeated as long as this marker status is present.

The marker status will be terminated with two basic conditions:

1. The water level has been corrected
2. The glass damage has been fixed

Since these two conditions are coupled by an AND link, this marker is triggered only when both conditions are met.

*Using several marker*

This marker can handle two basic problems:

A dropping water level below 80% and some kind of cracking glass. And yes, if this happens simultaneously, it is possible that water leaks. Due to the fact, 20% water inside an observation room can be very many water, a third sensor may be useful:

3	<input type="text" value="water leak observation room"/>	<input type="checkbox"/>	<input checked="" type="checkbox"/>
---	--	--------------------------	-------------------------------------

This sensor will find water or increased humidity levels at visitors observation room - something that can only be caused by a cracked aquarium windows (or something visitor- caused).

With the matrix settings, a second sensor can be configured:

<b>Marker 2</b>	<input type="checkbox"/>	And ▼	1	2	3	4
			<input checked="" type="checkbox"/>	<input type="checkbox"/>	<input checked="" type="checkbox"/>	<input type="checkbox"/>

This marker defines that there is a glass breach alert present and water is found at visitors observation room., dass ein Glasbruchproblem vorliegt und im Besucherraum zudem Wasser auftritt.

*The Or connection*

Okay, from now on the emergency conditions are set:

1. Glass breach and water level drops below 80%
2. Glass breach and water found at visitors observation room

Es However, it may now be the case that the water level drops and / or water is reported in the visitors' area without an obvious glass breakage. This may happen and someone need to mainenance this issue, but it is not really critical. In some cases it could be wanted.

To show this scenario, a third marker can combine both conditions with an OR:



This basic marker can be used as a non-critical overview lookup:

1. Water level below 80%
2. Unusual Humidity or liquids found at visitors observation room

With the OR operation, these two conditions can occur independently of each other - in both cases, the marker is set to high – on the other hand, this marker will only fall back to off position if all standard maintenance work is done.

*Switching outputs*

In this example scenario, many trigger points are included. For the matrix, these issues are configured:

- Glass breach **and** dropping water level
- Glass breach **and** water/liquids at visitors observation room
- Dropping water level **or** water/liquids at visitors observation room

Die kritischen Probleme sind hierbei mit festen UND-Bedingungen verknüpft, da ein schnelles Handeln erforderlich ist. Die Eskalationsstufe ist, dass alle 3 Ereignisse aufeinandertreffen: Es gibt ein Glasbruchproblem, der Beobachtungsraum läuft voll Wasser und der Füllstand auf 80% gesunken ist.

The critical issues here are linked to fixed AND conditions because quick action is required. All three problems together means, visitors can be endangered: There is a glass break problem, the observation room will be filled by water and the water level has dropped below

SensorMan2 Digital Outputs									
Port	Name	Logic	Marker						
1	Output 1	And ▼	<table border="1"> <tr> <td>1</td> <td>2</td> </tr> <tr> <td><input checked="" type="checkbox"/></td> <td><input checked="" type="checkbox"/></td> </tr> <tr> <td><input type="checkbox"/></td> <td><input type="checkbox"/></td> </tr> </table>	1	2	<input checked="" type="checkbox"/>	<input checked="" type="checkbox"/>	<input type="checkbox"/>	<input type="checkbox"/>
1	2								
<input checked="" type="checkbox"/>	<input checked="" type="checkbox"/>								
<input type="checkbox"/>	<input type="checkbox"/>								
2	Output 2	And ▼							

80%. Perfect for automatic emergency procedures - all critical I markers can be summarized and linked to an output:

As long as marker 1 and marker to are set to ON (high), output 1 will be triggered: :

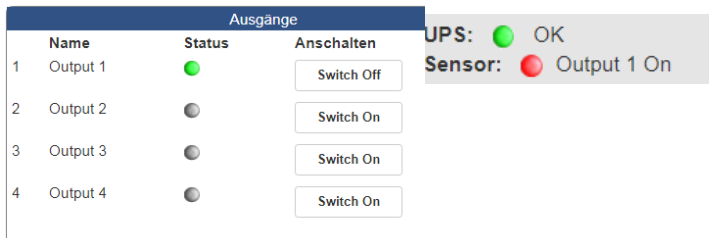

This output can inform ordinate and subordinate monitoring systems via alarm contacts, switch of switch off sockets near the floor, etc. Via the event "Output 1 On", any additional job chains can be created inside for advanced automatic emergency measures.

*Fallback o normal state*

The output will be switched off in case of one of these markers fall back to normal state.

**Note**

As with the configuration of the markers, you can create an And / Or dependency between up to 8 different markers. As an examle, this function is useful if a machine may only be startet if preconditions like pressure, temperature, etc. met specific operating values. By using the matrix, the output that unlocks the start button will not be released until all conditions have been met..

**Combination of sensors coming with the sensor matrix**

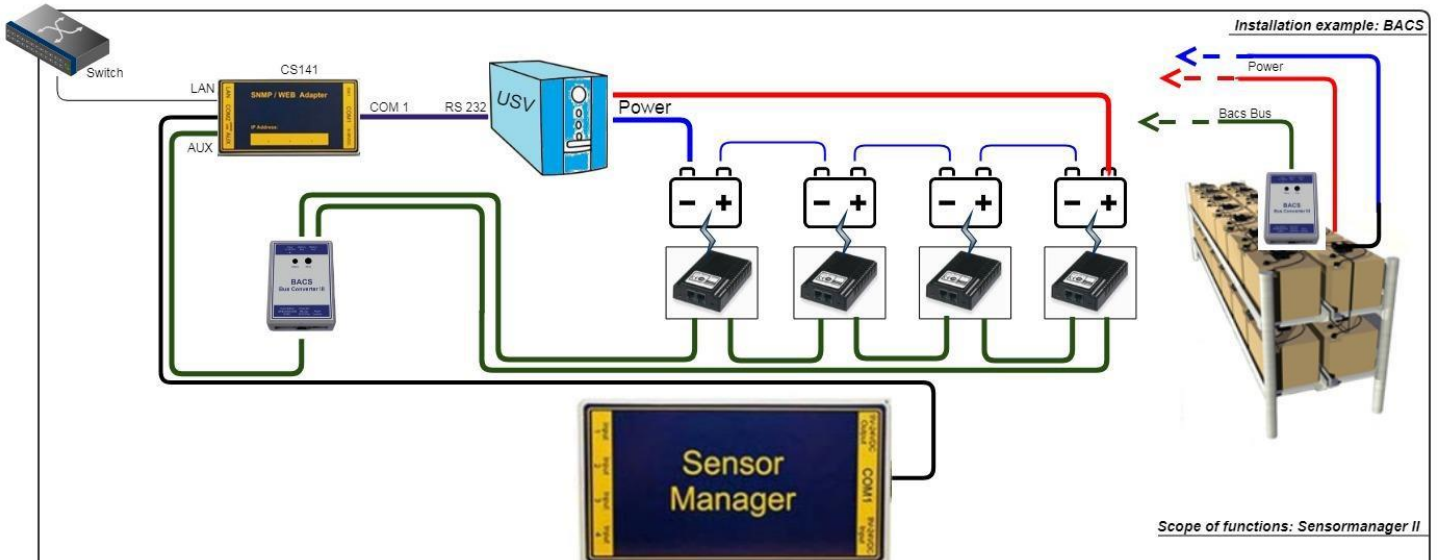

**Scope of functions: Sensormanager II**

Digital output area		Digital input area			Analog input area					
Active access control and warning		Advanced access control			Current and voltage					
<b>SM_IO</b>  Relay boxes	<b>SM_BUZ</b>  Acoustic alarm device	<b>SM_FLASH</b>  Optic alarm device	<b>SM_GLAS</b>  Glass breakage	<b>SM_MD</b>  Motion detector	 Any digital inputs	<b>SM_CMC</b>  Current sensor	<b>SM_VMC</b>  Voltage sensor			
Triggering, switching, feedback		Digitale Alarmsensoren			Temperaturen und Gase					
<b>SM_IO</b>  Relaisbox	 Door buzzer	 Switches	 Ventiles	<b>SM_SD</b>  Smoke detector	<b>SM_HYG II</b>  Digital water alarm	 Any digital inputs	<b>SM_T</b>  Temperature	<b>SM_T_H</b>  Combi sensor Temperature %Humidity		
Open standards		Open standards			Open standards					
The digital outputs support third-party sensor contacts.		The digital inputs support third-party sensor contacts.			Full support of third-party analog sensors					
 Monitoring	 Alarm systems	 Actuators	 Relays and contactors	 Sensors	 Actuators	 Alarm systems	 Feedback loops	 Sensors 0-20 mA	 Sensors 0-10V	 Level sensor

As soon as potential-free contacts 0-10 VDC / 0-20mA are provided by the target system, the SENSORMANAGER II can establish a connection between the target system and the CS141:  
 The scope of communication can be configured to interact from simple alarm wires up to complex communication structures with automatic feedback loops.

## Buzzer

The CS141\_BUZ is an acoustic alarm to be used with the CS141 SNMP adapter (CS141 SC or CS141 L). The CS141\_BUZ is based on a piezo element using an internal power supply. Due to this fact, no separate power supply is required. The volume is about 85 db. The CS121\_BUZ provides an RJ12 to be directly connected to CS141. Furthermore, an RJ12 socket for the output of PINs 1, 2, 3 to use external devices.

In addition, the acoustic signal of the buzzer can be remotely reset by closing a potential-free contact via the two-poled contact terminal block. Furthermore, a LED indicates a manually switched off alarm. This LED will stay blinking until it will be triggered by CS141 to normal state.

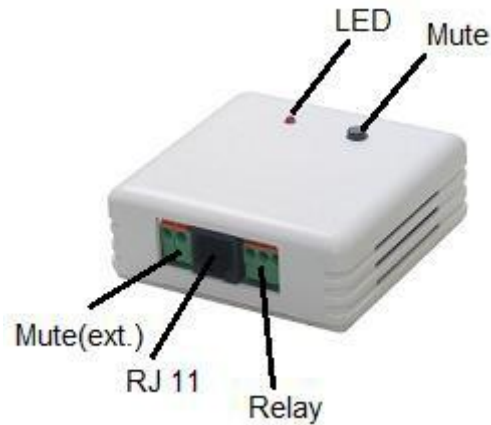

### Technical data:

voltage usage:	12 – 15 VDC
power usage:	ca. 30mA
Volume:	ca. 85 dB
Connection type:	wired, RJ12, 6_5, 5_m
Dimensions:	70 x 70 x 40 mm

### Connect to CS141:

Use enclosed cable to connect the buzzer CS141\_BUZ to AUX Port of CS141.

### Configure the buzzer:

#### Step: 1

**COM3**

Device

Under Devices/Setup, select Buzzer at COM and press Apply.

Step 2

Under Devices you find the buzzer alarm menu:



A configuration dialog box for the buzzer alarm. It contains four checkboxes: 'Relais' (unchecked), 'High freq' (unchecked), 'Mute' (checked), and 'Buzzer' (unchecked). At the bottom, there are two buttons: 'Apply' and 'Cancel'.

Apply transfers the current setting to the system configuration. Selected functions will be displayed at the BUZZER MONITOR. Furthermore, in the upper status bar the buzzer will be shown as operational.

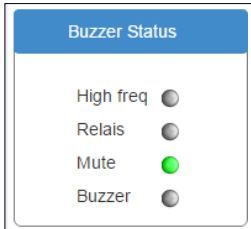

A panel titled 'Buzzer Status' with a blue header. It lists four items with circular indicators: 'High freq' (grey), 'Relais' (grey), 'Mute' (green), and 'Buzzer' (grey).



A horizontal system status bar with a light grey background. It displays four status indicators: 'UPS: OK' (green dot), 'AUX: Disabled' (grey dot), 'Sensor: Disabled' (grey dot), and 'Buzzer: OK' (green dot).

Step 3:

Select an event the buzzer shall toggle – as an example buzzer alarm if recognizes a power fail

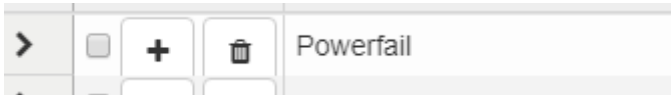

A partial view of an event list interface. It shows a list item for 'Powerfail' with a right-pointing arrow, a grey square icon, a plus sign icon, and a trash can icon.

Press + to open job configuration dialog:

Under Job select Buzzer:

Relays on

Additionally, the buzzer provides a relay for external connections to be switched.

Buzzer on

In case of a power fail the buzzer will be triggered. As soon as main power returned back, the event "Power restored" needs a job to switch off buzzer.

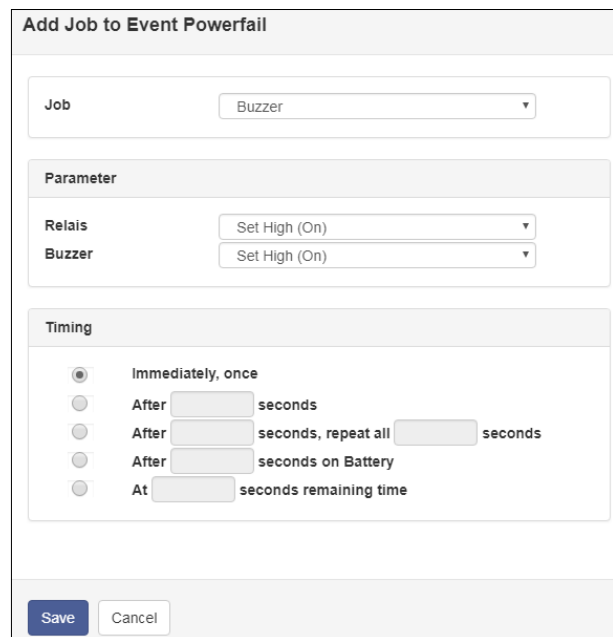

A dialog box titled 'Add Job to Event Powerfail'. It has three sections: 'Job' with a dropdown menu set to 'Buzzer'; 'Parameter' with two dropdown menus, both set to 'Set High (On)'; and 'Timing' with five radio button options: 'Immediately, once' (selected), 'After [ ] seconds', 'After [ ] seconds, repeat all [ ] seconds', 'After [ ] seconds on Battery', and 'At [ ] seconds remaining time'. At the bottom are 'Save' and 'Cancel' buttons.





At the event RELAIS ON, click + to start the configuration dialog:

Under Job, select the job to be executed because the buzzer's relay has been triggered.

Depending on your setting, a corresponding action will be triggered in addition to the triggered buzzer.

The screenshot shows a configuration window titled "Edit Job to Event Relais On". It contains the following fields and options:

- Job:** A dropdown menu with "Send SMS" selected.
- Parameter:**
  - Text:** "Das Relais des Buzzers hat ausgelöst."
  - Phone:** "+49176123456"
- Zeitpunkt:** A list of radio button options:
  - Sofort, einmalige Ausführung
  - Nach  Sekunden
  - Nach  Sekunden, wiederhole alle  Sekunden
  - Nach  Sekunden auf Batterie
  - Bei  Sekunden Restlaufzeit
- Buttons:** "Save" and "Abbrechen" at the bottom left.

**Note:**

If installed, you can also select the BUZZER via the AUX menu and may it have triggered accordingly. In that case, the AUX event will trigger the buzzer. The fact the buzzer is triggered will be able to trigger the next event. This behavior allows you to define as many individual events as well as event chains. You can even configure time delays ...

## GSM-Modem

A GSM modem provides the ability to notify responsible persons via SMS as an additional security measure. This is useful to help staff reducing response time.



GSM-T61

3GT61

### Technical data:

#### GSM-T61

Power supply: 12 – 15 VDC  
Power consumption: ca. 30mA  
Dimensions: 70 x 70 x 40 mm

#### 3GT61

Power supply: 12 V  
Power consumption: ca. 50mA  
Dimensions: 70 x 70 x 40mm

### Set up SIM cards

Both - The CS141 as well as GSM cannot deal with dial-in data of your service provider. The SIM card must be preconfigured according to your service provider in a network-enabled device so that it does not require dial-in data for operation. For detailed instructions how to configure your SIM card, please refer your mobile service provider.

#### Insert SIM card to GSM modem

Insert the SIM card. Ensure the contacts of the SIM card is upside. Insert the card into the device under light pressure until it locks in place. To remove, press the SIM card. The spring mechanism unlocks and the card can be removed.

#### Connect to CS141:

Connect the COM port of the modem directly to the COM2 port of the CS141. Connect the power adapter.

### How the GSM modem works

SMS modems provide the ability to notify responsible contact persons or administrative personal independently to any other automatic notification procedures in a very direct way. Due to the fact the GSM modem is a standalone device, it will work even in worst case scenarios when the intranet of a company is not available.

If emergency situations occur, it will help to shorten reaction time chain essentially.

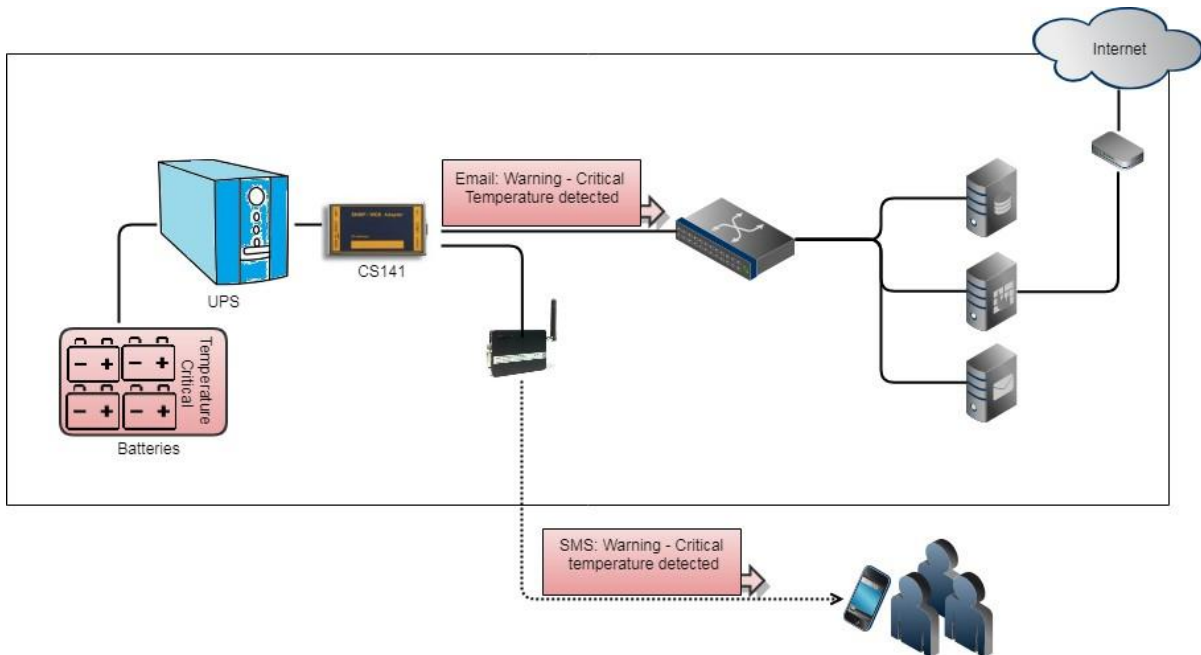

In cooperation with other auxiliary devices, the GSM modem can be configured for numerous events:

- Critical temperature measurements
- Door contacts / access control and unauthorized entry
- Parent and child system failures
- Emergency ventilation usage
- ...

Please note that a GSM modem is intended for sending short messages and is not designed to connect to the CS141 via the local mobile network. Currently the following options are supported:

- A GSM-Modem as serial standalone device
- IP/SMS-Gateway SMS communication

### *Setting up the SIM card*

There is no option to store access data for the SIM card inside the GSM modem or at the CS141. The SIM card must be configured accordingly by a network-compatible device to ensure no dial-in data ("without PIN") will be required for operation: The corresponding configuration guide for your SIM card can be obtained from your mobile service provider as well as from the operating instructions of the device selected for the configuration.

### *Insert / remove the SIM card*

Once the SIM card has been configured appropriately to be used with the GSM modem, it can be inserted into the device. Please note that you insert the SIM card with the contacts upwards with slight pressure until it locks in place by a spring mechanism. To remove, press the SIM card to unlock the mechanism:

The card pops out and can be removed.

CS141: Setting up the GSM modem for serial usage

For this configuration step, navigate to the following menu



Connect the COM port of the modem to COM2 interface of the CS141 and connect the power adapter. After connecting, open the CS141 system tab Devices. At COM-Port 2, Select GSM Modem

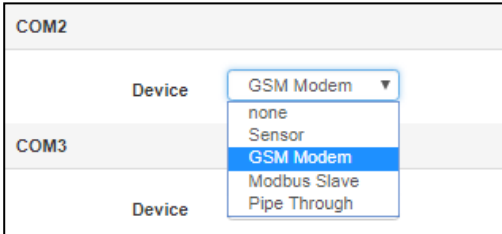

The GSM modem symbol should appear in the upper bar and show the quality of the signal accordingly:

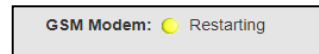

in addition, the CS141 will display the system tab GSMModem:



Serial COM port connection

To use a serial connected GSM modem, select com as operating mode.

If necessary, adjust the values for baud rate parity and stop bit. Please default values in normally represent the optimal setting and do not need to be changed.

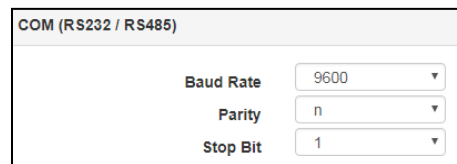

Using an IP modem

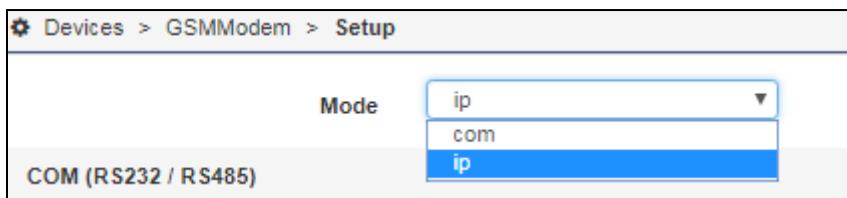

As special feature the CS141 is the support of a connection via LAN. COM2 is not necessary and can be used for other external devices. Under Mode, select IP. Enter the IP address and port number the CS141 will be able to access the IP modem.

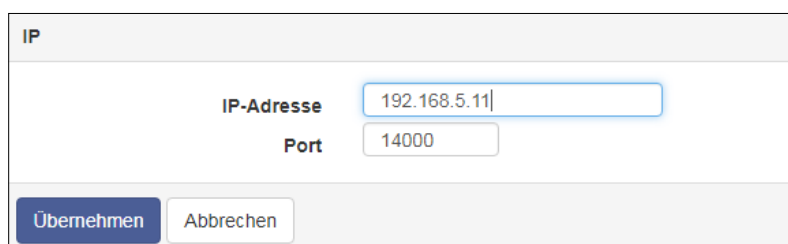

Valid IP address can be obtained by local administrators. if used, the CS141 will pass the data to the IP modem.

Job configuration using an SMS

Under UPS event handling, choose the event *Powerfail*.



Press **+** to begin with the job configuration dialog

Choose the job Send SMS.  
SMS text allows you to enter a small text message.

Under Phone, enter the mobile phone number of the SMS receiver.  
Ensure there are no spacers at the phone number you entered.

Use Timing to configure how often an SMS should be sent.

Press Save to finish job configuration.

The example dialog screenshot job will be triggered in case of a power fail occurs and send an SMS. If several parties need to be informed, define a separate job for each mobile number.

*When you need an sms if other devices are triggered*

Any device that is listed with a system event can be used to trigger an sms job. In this example, a buzzer will be used to trigger an sms.

		Ereignis	Jobs	Log	E-Mail	E-Mail Trap	RCCMD Shutdown	RCCMD Nachricht	RCCMD Execute	UPS Shutdown	Buzzer	RCCMD Trap	Send WOL	Send SMS
>	+ [ ]	contains...	[ ]											
>	+ [ ]	Relais On	1	1	0	0	0	0	0	0	0	0	0	0
>	+ [ ]	Relais Off	1	1	0	0	0	0	0	0	0	0	0	0
>	+ [ ]	Buzzer On	1	1	0	0	0	0	0	0	0	0	0	0
>	+ [ ]	Buzzer Off	1	1	0	0	0	0	0	0	0	0	0	0

At the event *RELAY ON*, click **+**

As Job, choose SMS, enter the text message and a valid phone number.

As a consequence, the event chain will be shown as followed:

Because there is a power fail, the buzzer is on and the relay is on. Because the Relay is on, the SMS will be sent with a custom text and logged accordingly

**Note:**

These event chains are very capable: In theory, it is possible to set up very complex event chains, where a job triggers the next event, etc. – you can use inputs and outputs to communicate all over the IT without the need of a network: “High/Low” or “ON/OFF” can trigger many things and produce complex notification alerts.

But be careful when using long event chains: They may brake if a single device is not available or configured accordingly.

## CON\_AUX4 and CON\_R\_AUX4

There is more than one method to communicate with parent and child systems: The external devices CON\_AUX4 and CON\_R\_AUX4 provide input as well as outputs to get information as well controlling third-party devices:

To start configuration, define COM3 as AUX port. Type will be used to toggle between CON\_AUX4 and CON\_R\_AUX4.

### Configuration

Once the AUX service has been started, the general operability is displayed accordingly in the upper bar. Please wait until the service is ready to use before accessing the configuration menu - it will appear automatically as a sub menu at Devices.

Depending on whether a CON\_AUX4 or CON\_R\_AUX4 has been connected, the configuration screen will differ:

Port	Name	NC-normally closed
1	AUX Port 1	<input type="checkbox"/>
2	AUX Port 2	<input type="checkbox"/>
3	AUX Port 3	<input type="checkbox"/>
4	AUX Port 4	<input type="checkbox"/>

Figure 1: Configuration menu – CON\_AUX4

Port	Name	Output	NC-normally closed	Switch on cs141 Powerup	Powerup Delay (seconds)
1	AUX Port 1	<input type="checkbox"/>	<input type="checkbox"/>	<input type="checkbox"/>	0
2	AUX Port 2	<input type="checkbox"/>	<input type="checkbox"/>	<input type="checkbox"/>	0
3	AUX Port 3	<input type="checkbox"/>	<input type="checkbox"/>	<input type="checkbox"/>	0
4	AUX Port 4	<input type="checkbox"/>	<input type="checkbox"/>	<input type="checkbox"/>	0

Figure 2: Configuration menu – CON\_R\_AUX4 Port

#### 1: Port

Current port number

#### 2 Name

Since the cable of the target device can be up to 60 meters, define a name or location. The field Name is freely editable.

#### 3 Output

The ports can be configured as an output to switch potential-free contacts. This function is only available at CON\_R\_AUX4.

#### 5 NC normally closed

Determine if the input / output normally contains an open or closed contact. Among other things, this function defines the alarm behavior

#### Switch on cs141 Powerup

The port is automatically switched on if the CS141 is starts or after reboot.

#### 7 Power up delay

During CS141 boots, the port will be turned on after predefined seconds. This allows a time-delayed startup or switching through potential-free contacts during a restart.

#### 8 Apply / Cancel

Apply will save the configuration and restart the service – a reboot is not necessary. Cancel will abort configuration dialog without saving data.

#### Define jobs to an AUX-Port

Under devices, navigate to AUX Event configuration menu:

**Setup** AUX Event Configuration

>	+	Ereignis	Jobs	Log	E-Mail	Email Trap	RCCMD Shutdown	RCCMD Nachricht	RCCMD Execute	UPS Shutdown	AUX	RCCMD Trap	Send WOL	Send SMS
>	+	contains...												
>	+	AUX Port 1 High	0	0	0	0	0	0	0	0	0	0	0	0
>	+	AUX Port 2 High	0	0	0	0	0	0	0	0	0	0	0	0
>	+	AUX Port 3 High	0	0	0	0	0	0	0	0	0	0	0	0
>	+	AUX Port 4 High	0	0	0	0	0	0	0	0	0	0	0	0
>	+	AUX Port 1 Low	0	0	0	0	0	0	0	0	0	0	0	0
>	+	AUX Port 2 Low	0	0	0	0	0	0	0	0	0	0	0	0
>	+	AUX Port 3 Low	0	0	0	0	0	0	0	0	0	0	0	0
>	+	AUX Port 4 Low	0	0	0	0	0	0	0	0	0	0	0	0

Click + to start the configuration dialog.

Possible jobs and timing configuration is similar to UPS event configuration

### Add Job to Event AUX Port 1 High

Job:

---

**Parameter**

Text:

---

**Zeitpunkt**

Sofort, einmalige Ausführung  
 Nach  Sekunden  
 Nach  Sekunden, wiederhole alle  Sekunden  
 Nach  Sekunden auf Batterie  
 Bei  Sekunden Restlaufzeit

This example will trigger a job in case of AUX Port 1 is set to high. (on)

Trigger AUX Ports to high/low (on/off):

The AUX ports can be triggered as a job:

### Add Job to Event Powerfail

Job:

---

**Parameter**

Port Number:

Command:

---

**Zeitpunkt**

Sofort, einmalige Ausführung  
 Nach  Sekunden  
 Nach  Sekunden, wiederhole alle  Sekunden  
 Nach  Sekunden auf Batterie  
 Bei  Sekunden Restlaufzeit

As an example, open Event Powerfail at UPS event handling. Select job AUX. Choose the port number that should change a state in case of a power fail occurs. Under Command, select the state the AUX port should be switched to.

**Note:**

The port state to be switched to is completely independent to the actual switching state. If the port is set to high/on and you switch the port to high, it will be switched accordingly again. Timing configuration is similar to other jobs

*Switch an output*

With CON\_R\_AUX 4, it is possible to switch a potential-free relay contact on activation:

*Manually switched*

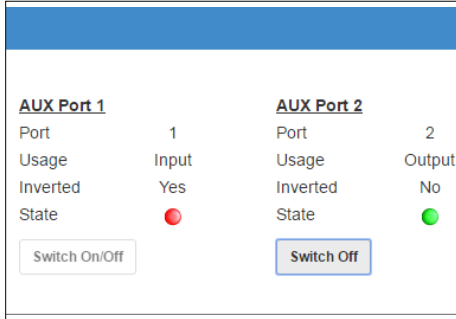

→ Manual switching on / off of a port

Each channel defined as output can be manually switched by pressing the Switch on button at AUX monitor.

*AUX status monitor*

For monitoring, CS141 provides an AUX Status Monitor. To open the AUX Status Monitor, select AUX Monitor from the top-level menu:

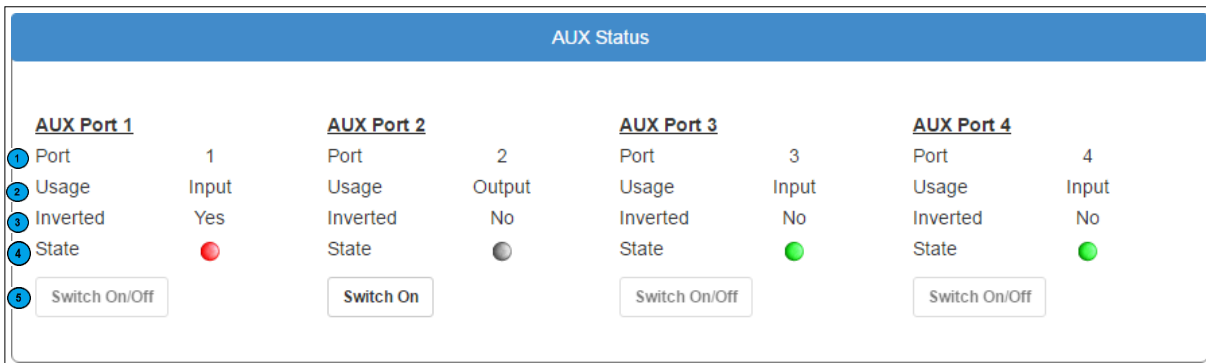

Figure: CON\_R\_AUX 4 AUX Monitor: Port 1 is inverted, port 2 is output and port 3/4 is default

**1: Port**

Port number shows the current port.

**2: Usage**

Usage shows whether the used port is configured as input or output.

**3: Inverted**

Inverted provides information about the behavior of how the connected device should be interpreted. There are two valid states:

*Inverted: No*

The connected contact must normally be closed.

*Inverted: Yes*

The contact is normally considered "open". This function can thus be used to invert the alarm behavior.

**4: State**

State displays the current switching state. Please note this state will change according to the LEDs at CON\_AUX4 and CON\_R\_AUX4. Due to the fact web technology is used, there is a time delay based on refreshing time of the browser.

**5: Switch on /off**

If a port is defined as output, this button will toggle the current state of the output.



## Scheduler

For this configuration step, navigate to the following menu:

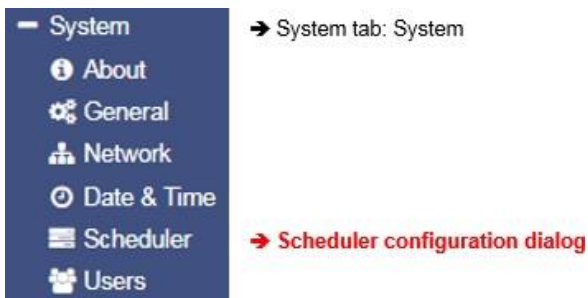

Regardless of all system events, the models of the CS141 series offer the possibility to run jobs at freely definable times.

These so-called scheduled jobs can be used, for example, to control subordinate systems, to restart computers, to perform battery tests, etc.

*Configuration menu for scheduled jobs*

As factory default configuration, no job is defined. They need to be defined by administrators or engineers

Press **+**: to start scheduled task configuration dialog

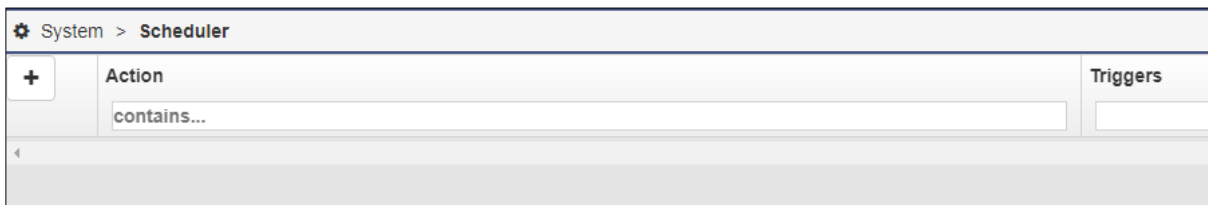

The job configuration dialog is similar to UPS event job configuration dialog. Timing configuration differs due to the fact these jobs have to be triggered independently to UPS alarm states:

Start: enter date and time the job will be executed the first time.

Repeat toggles the job repeating behavior

These values are valid:

One time: only one execution

Daily:

Every day depending on system time

Weekly:

Once a Week depending on system time

Monthly:

Once a month depending on system time

Timing	
Start	<input type="text" value="08.03.2018"/> <input type="text" value="10:52"/>
Repeat	<input type="text" value="One Time"/>
Triggers	At 10:52 on 3/8/18 one time

### Note:

In some cases, jobs can be set up to vary according to the configuration of connected devices.

## Webserver

For this configuration step, navigate to the following menus:



### Note:

If possible, do not disable the web server!

In order to fit to some high security-compliance conditions, it may be desirable that the web interface of CS141 has to be switched off after configuration work. The CS141 operates exactly "as configured". But it will be a little bit awkward if you need to change or add settings afterwards.

For security reasons, there is no console access. Configuration work will be done via a standardized web interface.

### Webserver setting

HTTP Port	<input type="text" value="80"/>	→ Define the port for HTTP access
HTTPs Port	<input type="text" value="443"/>	→ Define the port for HTTPs access
Force HTTPs	<input type="checkbox"/>	→ Deny HTTP access/ HTTPs only
HTTP Refresh Time	<input type="text" value="10"/>	→ Time in seconds the UPS screen shall refresh
HTTP Default Page	<input type="text" value="UPS Monitor"/>	→ Select the start page after log in
Enable HTTP Tooltips	<input checked="" type="checkbox"/>	→ Use simple monitor for small screens
	<input type="checkbox"/> use Simple Monitor	→ Enable / Disable the Tooltip
Automatic Logout		
After	<input type="text" value="15"/> min <input type="checkbox"/> No Auto Logout	→ Automatic Logout function
<input type="button" value="Apply"/> <input type="button" value="Cancel"/>		→ Save / withdraw settings

### HTTP or HTTPs - Port settings

Setting up the HTTP port

The international standard for web access is port 80 - normally this port does not have to be changed. Anyway, since this is not a fixed standard, your IT infrastructure manager may use settings that differs. If this is necessary, you may use this setting to fit to your IT infrastructure right here.

Please note, if you use a custom port setting, you need to name the according port for web access.

- 192.168.3.1:85

In this example, the WEBMANAGER will only be accessible at the IP 192.168.3.1 and the port 85. With port 80, you would run into an error message that is generated by your web browser.

Der HTTPs Port

In case of using HTTPs, the standard port is port 443. Like the HTTP port, you may use this setting to define custom ports for HTTPs access.

### Note:

As soon as force https is active, `https://` is mandatory for a direct web access to the CS141. If you miss to use this syntax, there are two different types of web browser behavior:

Connection Timeout

Since CS141 answers in case of a HTTPS queries, the web browser waits some time and shows a connection timeout issue.

Forwarding (depends on which web browser is in use)

If several CS141 in your network are configured to use https only, your web browser may think you entered the wrong IP address and forwards you to another device.

### Force HTTPS

A standard HTTP connection on the Internet can easily be intercepted by intruders. In order to avoid this and to ensure secure data transmission, an HTTPS connection is recommended. By doing so, the connection is encrypted and the server is authenticated. The advantage is an increased data security, but at the cost of an increased response time, since the data is transmitted encrypted.

Force HTTPS prevents regular HTTP traffic and enforces to use HTTPS.

### HTTP Refresh Time

The CS141 provides dynamic update system status pages. Among other things, these pages display the status and many values of the UPS the CS141 is connected to. By default, the CS141 updates displayed screens every 10 seconds, but you may choose your own refreshing time.

### Use simple monitor

The CS141 offers two different displays as a UPS monitor, which differ in terms of layout and content:

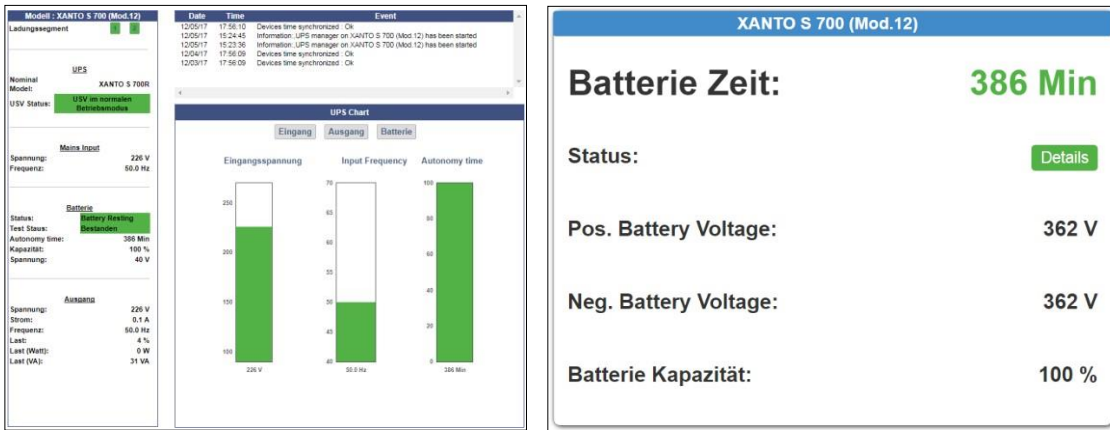

The simple monitor (Fig. Right) contains significantly less information, but better legibility.

### Enable HTTP Tool Tips

Tooltips are context-related pop up screens that appear automatically as soon as you move the mouse over a setting option. As a default, the tooltips are enabled. Unchecking this box will disable the tooltips.

### How to Enable / Disable the webserver

With Services>Setup, the CS141 provides functions to disable the build-in Web server service.



Please note that the complete user interface is linked to the web server - afterwards you cannot carry out any further configuration as well as accessing the monitoring screens. For an access of the user interface, resetting the device to factory defaults is mandatory.

Tutorial: Once upon a time, you switched the web server to off...

And now you want to take a look at the monitoring screens and they are gone. Any you do not really know what to do? This tutorial shows you how to reset your CS141 and start over again – the CS141 is not locked up completely ...

### Use Backups

“Disable the web server” is very powerful, so it takes a little bit planning before you set the web server restrictively to “OFF”: As soon as the web server has been disabled, it will be a little awkward to add some configuration at the CS141 – the current configuration interface is gone. But if you have a backup file you may be able to recover nearly the complete configuration of your device. Which final backup / restore strategy you choose, depends on what you want to achieve.

In principle, there are two basic scenarios:

1. You need to change configuration regularly  
Make the full data backup before you disable the web server. You can easily create the backup via the System> Backup configuration.
2. Change a single device that runs “as configured” by a new one  
Create a backup file after disabling of the web server. Since the configuration interface is offline, you cannot press System>Backup to create it. So just enter:

`http(s)://<your IP address>/backup`

You will be asked for the standard user name admin and the current password (Standard: cs141-snm).

#### Note:

In both cases, the rule is that a backup should only be used with device that comes with the same or a newer firmware version. An older firmware may not work as expected because changes during a firmware update may change the format of backup file, add features or something like that. The older firmware version may not know how to handle these changes.

### Einspielen des Backups

After you have switched off the web server, you can no longer change the configuration. If you do not have a backup now, you will have to completely reconfigure the CS141 after resetting the configuration.

Otherwise it works as followed:

1. Reset the CS141:  
At your web browser, enter this command:

`http(s)://<you IP address>/update`

Even the web server is already disabled, some functions will still work. One of these functions is the direct call of the update window:

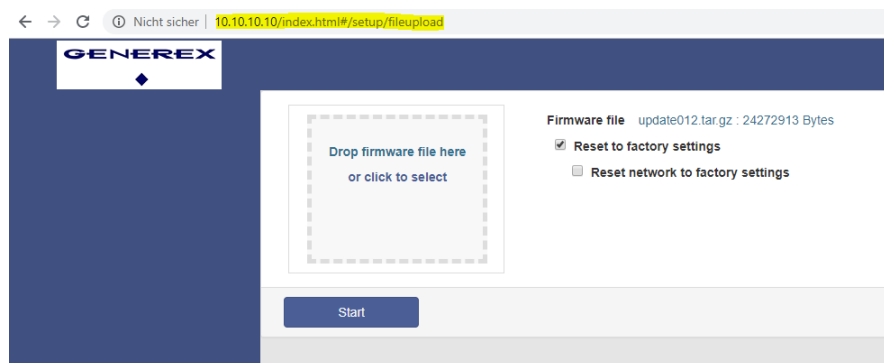

Marking „Reset to factory default will advise the CS141:

- Delete the basic device configuration
- Keep the network settings

After flashing, the CS141 will restart and the web interface is available. Open System>Backup and use drag and drop to place the backup file.

2. Change the device 1:1 by another device / spare part

Open the flash routine as described, and then insert the backup file. Since you have a backup file with a disable web server, the backup will lock up the user interface! You cannot change settings. The new device will run as configured like your old device. Ensure to use all backup file items.

- If you want to refresh a broken configuration file, just use the complete backup file.
- If you want to change the device by a spare part, please note, that you need to depower the original device before powering up the spare part. Otherwise you may get an IP address conflict.

## Tutorial: How to create a .pem-file

There are many ways to create a key and a certificate.

A comfortable freeware tool is X Certificate and Key Management.

This tool offers not only the possibility to create valid certificates but also the option to include necessary keys. After creating, these files can be exported to be used with the CS141.

In addition, this tool comes with a small database to manage all keys as well as certificates easily. This tool is not the only one of its kind, but highly recommended:

- Easy to use
- Fast key and certificate creation (administration)
- This tool is available for Windows, Apple and Linux.

### Create certificate and key

#### Step 1. Download and Installation

The tool is available through several download sources, a good and clear download link is presented here:

<https://hohnstaedt.de/xca/>

Please note that download links may change over time and need to be adjusted accordingly. The setup file includes an installer that guides through the installation process.

#### Step 2 Create database (example: Windows version, Linux and Apple may vary slightly)

After installation, click on File and create a new database. It is not necessary to enter a password to protect the database

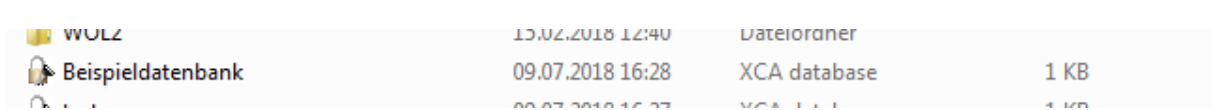

Internal name	Type	Size	Use	Password
WOLZ		13.02.2018 12:40	Dateioroner	
Beispieldatenbank		09.07.2018 16:28	XCA database	1 KB

This database can be stored and re-opened for later usage.

#### Step 3: Create and export a private key

Go to private Keys and press the button New Key:

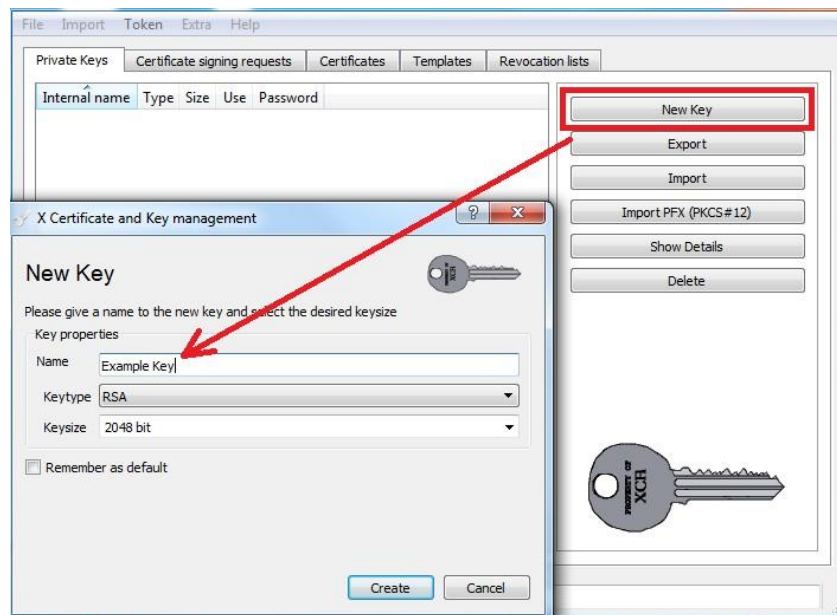

Click Create to complete this process. The key will be provided in the database containing a corresponding message.

This key is the first of two required parts to create a valid PEM file.

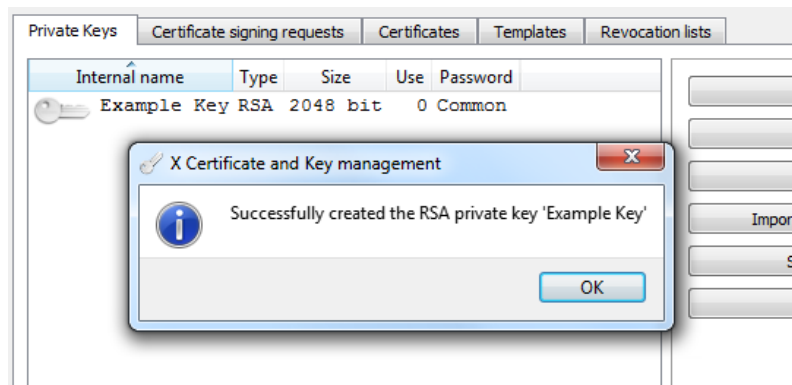

After creating, export this key. Remember to rename the export file name to server.pem:

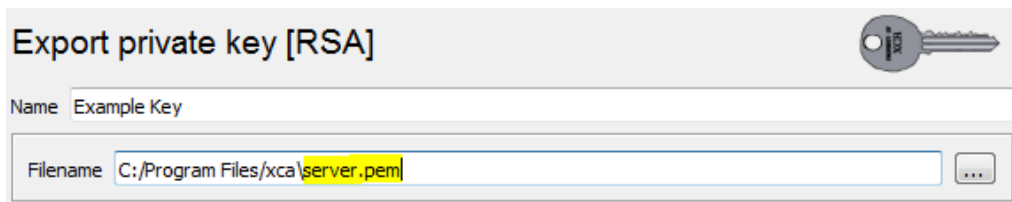

There is no need for special editing tools required - Edit this file with a regular text editor and attach the certificate.

#### Step 4: Creating / exporting the certificate

The second part of the PEM file contains the necessary certificate to operate the CS141 with force HTTPS mode. To create the certificate, open Certificate signing request click on "New request" This will begin the certificate configuration dialog:

Most Important are information about holder, extensions and key usage.

Distinguished name			
Internal Name	Beispielzertifikat	organizationName	GENEREX
countryName	HH	organizationalUnitName	GENEREX-IT
stateOrProvinceName	HH	commonName	GENEREX
localityName	GENEREX_Demo	emailAddress	support@generex.de

Enter the certificates owner data. Adjust the data according to your company. With Add you hand over these data inputs to the database of the tool.

#### Extensions

With extended functions, you can set the validity of the certificate:

Validity		Time range	
Not before	2018-08-20 11:11 GMT	10	Years
Not after	2028-08-20 11:11 GMT	<input type="checkbox"/> Midnight <input type="checkbox"/> Local time <input type="checkbox"/> No well-defined expiration	

Passen Sie diese Daten an, um die Dauer Customize this data to determine the duration of the certificate. Apply with Complete this process.

## Key Usage.

Check both check boxes and mark all modules you wish to include in your new certificate:

X509v3 Key Usage	X509v3 Extended Key Usage
<input checked="" type="checkbox"/> Critical	<input checked="" type="checkbox"/> Critical
Digital Signature	TLS Web Server Authentication
Non Repudiation	TLS Web Client Authentication
Key Encipherment	Code Signing
Data Encipherment	E-mail Protection
Key Agreement	Time Stamping
Certificate Sign	Microsoft Individual Code Signing
CRL Sign	Microsoft Commercial Code Signing

If you are not sure of the exact purpose for which you want to use the certificate, in case of doubt, activate all the options offered to you. This will allow the certificate to maximum functionality. After you have entered all data, click OK at the lower right corner

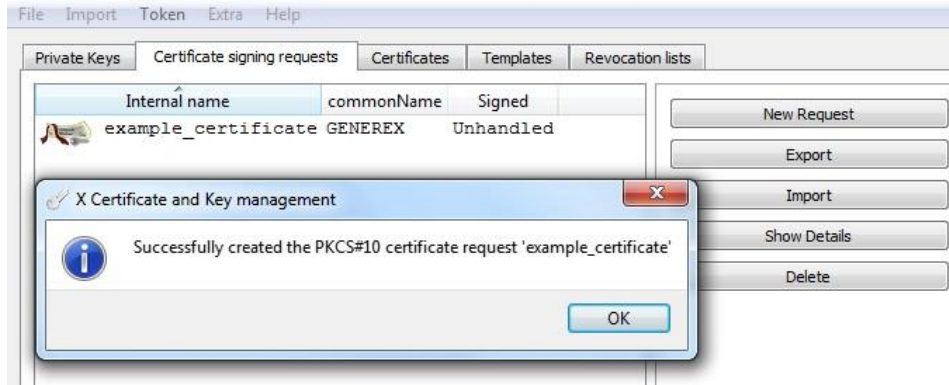

Export the certificate to a .crt file.

*Stitch together...*

From now, you should have two different data:



Open the certificate with an editor and copy the content. The content looks something like this:

```
-----BEGIN CERTIFICATE-----
MIIEoDCCA4igAwIBAgIBATANBgkqhkiG9w0BAQsFADCbjTElMAkGA1UEBhMCSEgX [...]
hQ9t4jit2VSTnv4rIrHoT8j5/yEFpRKg6D/5zmavsc194gUp
-----END CERTIFICATE-----
```

*It is important that you completely copy the entire file including BEGIN CERTIFICATE and END CERTIFICATE! Otherwise it will not work.*

open the file server.pem and copy the certificate under the key:

```
24 HbASwwKBgQCsZfpDOEsNZis3h6khXXWIj3/A1NKmWB4Hsq9EgVKMZasKK8mGLIqD
25 RmkXwyQQgoTJuknaDLAFXQV4XBPpEC6N5/zvNj1LKYGEKik4ibwlyF52CqhPtii
26 DOPUGYKLeDfEAXNK5mKq349qC5C177YFDEFrAtiZDysh2KgRR0kCg==
27 -----END RSA PRIVATE KEY-----
28
29 -----BEGIN CERTIFICATE-----
30 MIIEoDCCA4igAwIBAgIBATANBgkqhkiG9w0BAQsFADCbjTElMAkGA1UEBhMCSEgX
31 CzAJBgNVBAGTAkhIMRUwEwYDVQHDAXHRU5FUKVYX0R1bW8xEDA0BgNVBAoTB0df
32 TkVSRVgxZzARBgNVBA5TCkdFTkVSRVgtSVQxEDA0BgNVBAMTB0dFTkVSRVgxITAf
33 BekahkiG9w0BCEWEnN1cHBvcnRAZ2ZVuZXJleC5kZTAeFw0xODA3MDkxND0zMDBa
```

Save this file without changing the file name, the file extension or file type.

CS141: Inserting the .pem file

Open CS141 and navigate to the certificate web server:

### Upload TLS Certificate for Webserver

Drop server.pem File here  
or click to select

PEM file <no file selected>

Upload

use drag'n'drop to copy server.pem into the field provided by CS141. Upload will start the upload and import process. Once upload is finished, you can test the certificate by typing:

http: // <your IP address>

https: // <your IP address>

If both inputs respond as desired, you can use Force https to enable explicit encryption.



## Diagnostic: Status LED's

The CS141 offers several options for diagnosis. The fastest method is a quick visual inspection of the LEDs

To perform a quick inspection, take a look at the two LEDs in front of the CS141:

Green LED	Red LED	Adapter
OFF	OFF	No Power
OFF	AN	Boot in progress
OFF	SLOW BLINKING	Update in progress
AUS	FAST BLINKING	Update failure
ON	ON	Communication lost: UPS or external device
SLOW BLINKING	OFF	Everything is OK with the world

After logging in, the CS141 will display a more detailed overview of the current system state:

UPS:  Ready

A green marker indicates communication without problems.

Please note the setting no UPS device selected will show a dummy screen and the LED will also be green.

UPS:  Initializing

A yellow marker is displayed if:

- The device will initialize and the communication is being established
- there is a warning behavior. It might be required appropriate intervention in the near future.

UPS:  Temperature Bad

If the LED is red, an alarm or critical condition is currently detected:

- The CS141 has lost communication with a connected device
- There is a system critical condition, which requires a timely intervention.

The type of the alarm is displayed in detail.

UPS:  Communications Lost

A blue marker indicates that the device was probably configured correctly, but no initial communication has been established.

Sensor:  Disabled

A gray marker and the description disabled means that a device has been completely deactivated and cannot provide any data.

**Example: Quick diagnosis using LEDs and marker**

**At the front of the CS141 both, red and green LED's, are on, but they should be off or just the green one flashing slowly. The UPS is definitely recognized ... and seems to work normally.**

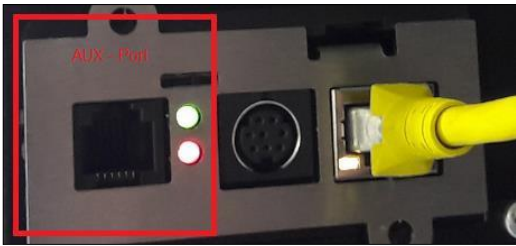

As you can see the red and the green LEDs are lit statically. Since it is a slot card, it is plugged into the UPS and is supplied with the necessary information about it.

The yellow plug is the ethernet cable to connect the CS141 to the local network

In this example scenario, the AUX port is the cause of a communication error:

After logging into the CS141, the top status bar displays the following information about enabled devices:



The UPS is set correctly and has made the communication accordingly. The AUX port, on the other hand, is set to initializing. However, since the AUX port has no device connected to CS141, the yellow marker will change from yellow to blue in time, while the LEDs on the front of the CS141 continue to glow green and red statically.

Due to the fact the UPS indicates a green marker and other devices are set to disabled, the AUX-Port will cause trouble.

*What you can do:*

Once a CON\_AUX4 or CON\_R\_AUX4 device has been connected to the AUX port of the CS141 and successfully initialized, the marker in the status bar will turn to green and provide feedback with OK. Furthermore, the LED status at CS141 will indicate normal operating mode.

If no AUX device is to be used, you can set the AUX port at COM3 to none in the general configuration menu. In this case, the AUX port will be disabled as well as the AUX marker will be removed from the top status bar.

As a consequence, the LED at CS141 will indicate normal operating mode.

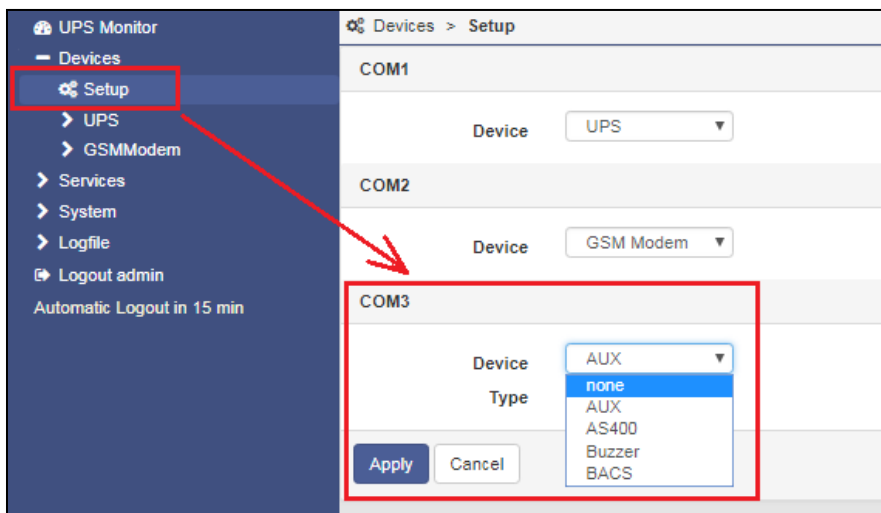

## Logfiles

### Event Log

Since this is not a configuration step, just navigate to the following menu:

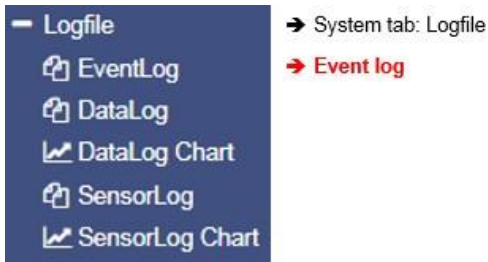

The event log contains all actions concerning the CS141 and the UPS are recorded. The event history will be written by any event containing a log job. The most significant jobs are included by default settings. Administrators may create, edit and delete default settings as well as creating custom log entries.

Logtime	Logtext
<input type="text" value="Logtime search"/>	<input type="text" value="Logtext search ..."/>
12/07/2017,09:38:01	time synchronization job : OK
12/07/2017,09:38:01	Restart NTP service: OK
12/07/2017,09:33:45	UPSMAN on No UPS model defined has started
12/07/2017,09:33:25	CS141L V1.63 - OEM 32

[Download als CSV Datei](#)

After reboot the first entry is a message by CS141 with its OEM ID:

12/07/2017,09:33:25	CS141L V1.63 - OEM 32
---------------------	-----------------------

Please note the latest entry is always on top of the list. Download as CSV file creates a CSV file from this event log and stores it locally on your hard disk:

DataLog	04.10.2017 15:45	MICROSOFT EXCEL-C...	400 KB
eventlog	07.12.2017 10:45	Microsoft Excel-C...	1 KB

Any program that can deal with CSV files can be used to open the event log.

	A	B
1	12/07/2017,09:33:25, CS141L V1.63 - OEM 32	
2	12/07/2017,09:33:45, UPSMAN on No UPS model defined has started	
3	12/07/2017,09:38:01, Restart NTP service: OK	
4	12/07/2017,09:38:01, time synchronization job : OK	
5		
6		

In case of current memory to store event, logs are exhausted, the CS141 will open an archive file and move the current event log. This archive file will be provided for both: downloading as well as instant view.

**Note:**

Depending on the configuration, the system events in the event log are kept for up to three months. As soon as the running memory for the current event log file is exhausted, the files are stored alternately in up to two archive files. This generally provides a monitored period of up to 9 months from initial startup.

*Navigate between logfiles*

By default, the current event log is displayed

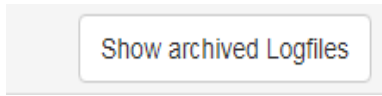

Administrators are able to toggle between the two logs by clicking the button "Show archived Logfiles" in the upper right corner.

By doing so, the label of this button will change:

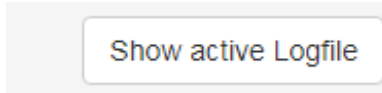

To return to the active log file, press the button labeled "Show active log file"

Data Log

Since this is not a configuration step, just navigate to the following menu:



Logfile > DataLog															
↻															
Date,Time	InVolt1	InVolt2	InVolt3	InFreq	Load1	Load2	Load3	BattVolt	UPSTemp	BattCap	OutVolt1	OutVolt2	OutVolt3	OutFreq	AutonomTime
01/01/2000,00:04:51	n/a	n/a	n/a	n/a	n/a	n/a	n/a	n/a	n/a	n/a	n/a	n/a	n/a	n/a	6.0
01/01/2000,00:07:59	230.0	230.0	230.0	50.0	100.0	n/a	n/a	n/a	n/a	100.0	n/a	n/a	n/a	n/a	6.0
01/01/2000,00:11:06	230.0	230.0	230.0	50.0	100.0	n/a	n/a	n/a	n/a	100.0	n/a	n/a	n/a	n/a	6.0
01/01/2000,00:14:16	230.0	230.0	230.0	50.0	100.0	n/a	n/a	n/a	n/a	100.0	n/a	n/a	n/a	n/a	6.0
01/01/2000,00:17:23	230.0	230.0	230.0	50.0	100.0	n/a	n/a	n/a	n/a	100.0	n/a	n/a	n/a	n/a	6.0
01/01/2000,00:20:31	230.0	230.0	230.0	50.0	100.0	n/a	n/a	n/a	n/a	100.0	n/a	n/a	n/a	n/a	6.0
01/01/2000,00:23:39	230.0	230.0	230.0	50.0	100.0	n/a	n/a	n/a	n/a	100.0	n/a	n/a	n/a	n/a	6.0

The data log recognizes measurement data of the UPS. Due to the fact these are provided with a time stamp, they can be combined with the event log:

Analysts can build event chains with additional UPS data.

Like the event log, data log can be exported as CSV file as data backup. The data log stores the entries every 3 minutes and keeps the entries 8 weeks as the current data log file. After that the actual data log will be moved to an archive file and a new data log for the current data is opened.

The CS141 provides storing up to 2 independent archive files:

In addition to the current period, there are up to 24 weeks available. After expiry of the time, the oldest archive file is replaced. As with the event log, administrators can toggle between active log and achieved logfiles.

Data log Diagram

Since this is not a configuration step, just navigate to the following menu:

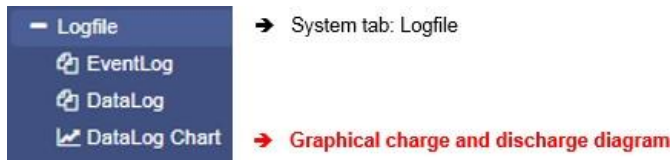

With data log Chart CS141 provides a graphical presentation of the battery history:

This feature allows to examine all entries within the data log exclusively. Single entries can be selected by using checkboxes:

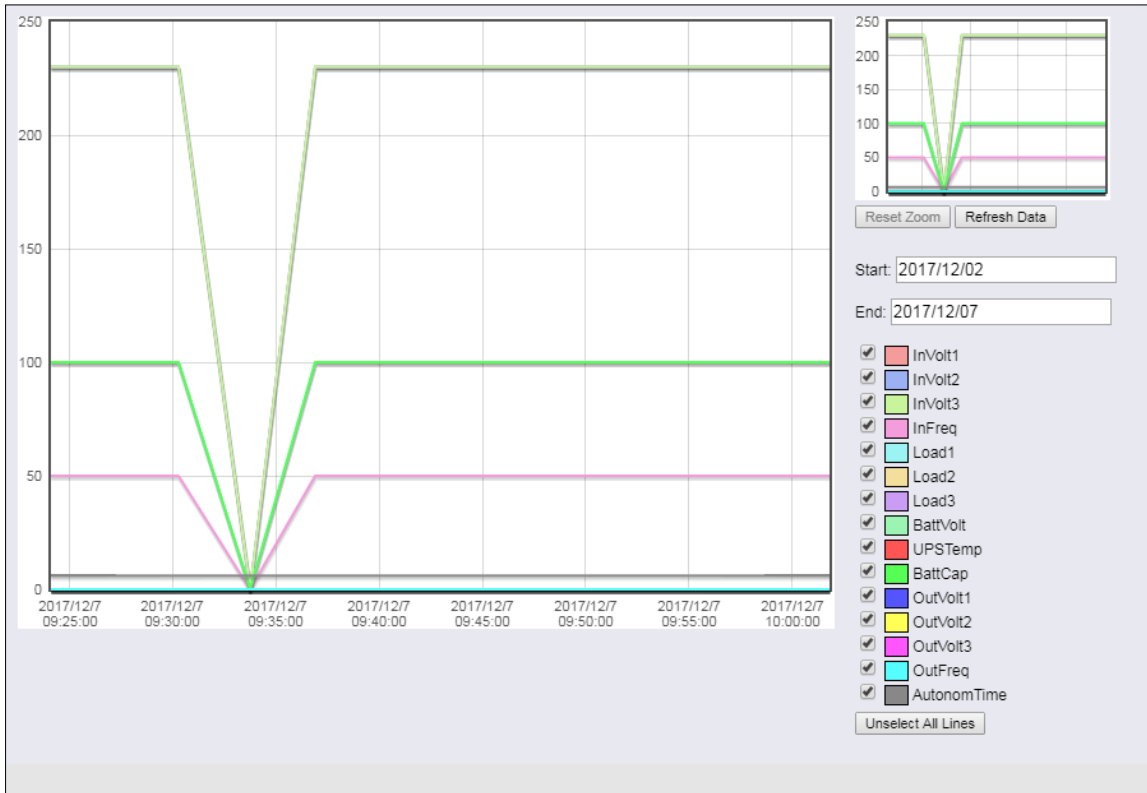

In addition to the current values, the CS141 provides selecting specific values from current databases.

As a default, all check marks are set when called. You can use the Unselect All Lines function to remove them and set the relevant checkmarks.

*How to use the calendar*

The calendar feature provides a quick of existing time periods that are selectable. Click the date field to bring calendar:

The dates of the corresponding period automatically loaded and displayed main window.

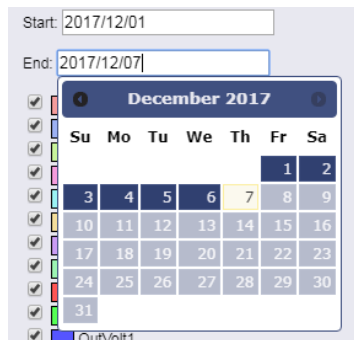
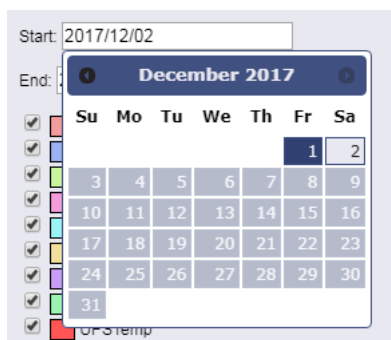

overview  
up the  
are  
inside the

### Zoom the Chart

The CS141 provides zooming the data and thus obtain a detailed view within the displayed measurement data.

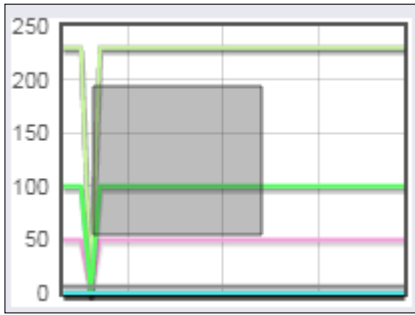

To refine display, drag a frame inside the small window. The main window will automatically show a detailed view and provide a customized timeline.

Reset Zoom

The zoom function allows an enlargement of the timeline up to 2 minutes.

This function resets the zoom back to the original scope.

Refresh Data

This function updates the current data shown and refocuses the timeline.

### Premium function: The UPS alert history

This menu is only available if your UPS will support the functionality  
Since this is not a configuration step, just navigate to the following menu:



Not only the CS141 logs events - many UPS systems provide their own internal non-volatile memory to log events as well as internals. This information can provide very useful insights if irregularities occur after a configuration.

#### **Note**

The CS141 adapts itself to functions a UPS provides - The UPS Alert History is only available if your UPS supports this function.

#### *Reading internal event logs of the UPS*

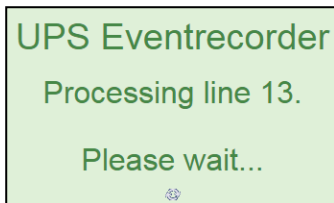

Each time the UPS Alert History button is pressed, the event memory of the UPS read out and displayed accordingly.

Please note that displayed status messages as well as the scope and information value may vary:

Some UPS models provide more useful information than others.

After reading, UPS data are displayed inside a chronologically arranged history. At the top of the list, you will find the oldest UPS log entries. At the bottom of the list, the latest entries will be shown.

```
2018/05/30 14:42:28.780 Event #298: ABM testing
2018/06/05 14:02:54.000 Event #290: Clock set
2018/06/11 10:06:07.610 Event #139: Inverter off
2018/06/11 10:06:07.610 Event #294: UPS off
2018/06/11 10:48:57.130 Event #139: Inverter on
2018/06/11 10:48:57.130 Event #298: ABM discharging
2018/06/11 10:48:57.170 Event #237: UPS on normal
End
```

End determines the last entry of the logfile.

### Exporting UPS data log

If needed for later analysis for statistical and diagnostic purposes, the CS141 provides to export and save the log as CSV file and save it locally to your hard disk



**Note:**  
The UPS Event Recorder polls the current list from the UPS with each call - These log data will not be cached or saved by CS141.

### Tools

The EXPONENTIAL POWER system tools are a collection of useful utilities to help in case of diagnostic problems. To ensure authorized access only, this menu acquires administrative credentials:

To open the Toolbox, navigate to the following menu:

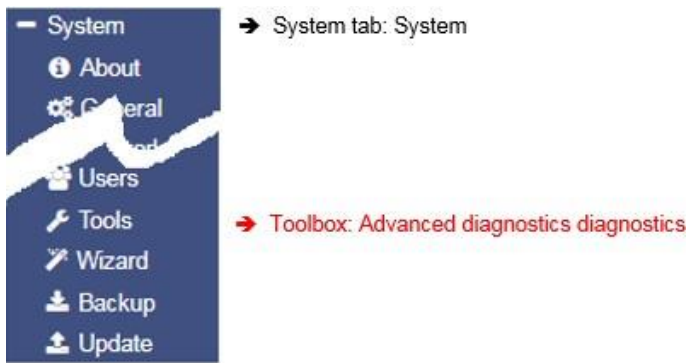

### Reboot

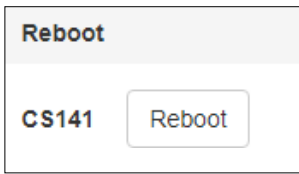

Due to the fact the CS141 accepts changes inside the configuration and starts or restarts the corresponding system services in real time, a complete restart is an exceptional situation. In case of a restart of the CS141, UPS continues its normal mode: A reboot of CS141 does not affect the UPS. To prevent an accidental triggered reboot, this feature was deliberately placed inside *Tools*.

### Tracer

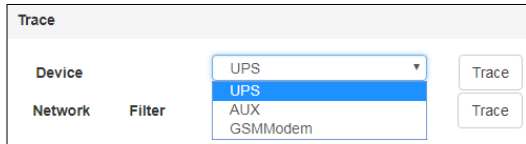

The Tracer is a comprehensive diagnostic tool for verifying communication between the CS141 and the connected devices as well as for identifying network problems.

Under Device communication information about external devices connected to CS141 can be queried. To track a device, open the context menu and select the device you want to monitor. As the screenshot illustrates, the CS141 provides COM 1 / UPS, COM 2 / GSMModem and COM 3 / AUX-Port:

#### COM 1 / UPS

The tracer will screen the current communication running at the serial RS232 port. Faults or faulty communication are displayed in real time and can be saved for later evaluation

#### COM 2 / GSM-Modem

The Tracer queries the communication between the CS141 and the GSM modem and displays the telemetry in real time. Errors and communication problems can be easily collected and saved for later analysis.

#### COM 3 / AUX

A CON\_AUX4 or CON\_R\_AUX4 can be connected via the AUX port. The tracer can interrogate communication with the device in real time.

**Note:**

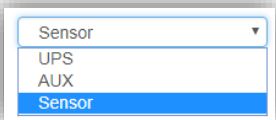

The Tracer adapts itself to the choice met under Devices in the configured in general port settings. If sensors or a Sensor manager 2 is configured instead of a GSM modem, the tracer will show these devices.

The button labeled with Trace starts the process. Depending on your browser's configuration an open a new tab will be opened to show the data stream of the communication between the device and the CS141:

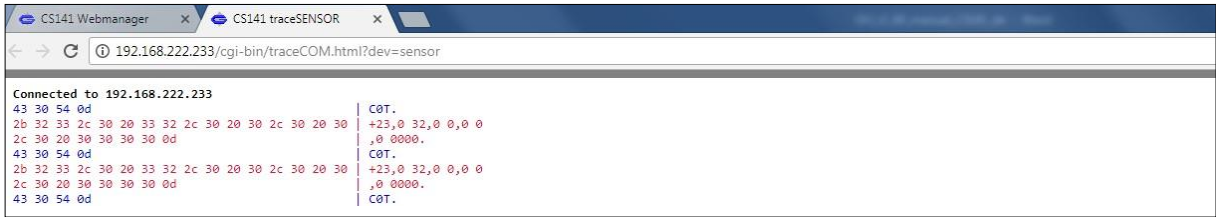

The trace ends automatically by closing this tab. Please note that the data will be discarded. To save the data, mark it with the left mouse button and copy the content with CTRL + C, and insert the information with CTRL + V to a text file.

*Available Tracing tool control options*

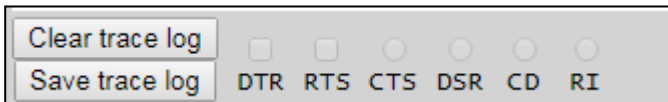

- Clear trace log

Clear trace log deletes the current display - the information cannot be recovered afterwards.

- Save trace log

This function will transfer the current browser content into a standardized text file.

**Note**

This log file contains the complete time-stamped communication between the CS141 and UPS connected to it: The CS141 asks and the UPS responds accordingly. Since these entries are time stamped, this communication may be compared to external events - this valuable information may help finding the cause of an incident.

The telemetry data file is placed in real time inside the memory of the web browser. By closing this window, the trace data file is automatically terminated and lost. Ensure saving data before closing the window of the web browser.

Trace file evaluation

Open the saved text file. Please note the extended text formatting - Ensure to use a text editor mastering extended text formatting. As an example, typical applications would be editors like sublime or the editor write by Microsoft Windows.

For a detailed analysis, the official protocol description of the UPS is necessary.

For further details, please refer to the manufacturer of your UPS.

Network-Scan

As special feature the CS141 provides an integrated network scanner to examine the LAN for issues and errors. The network scan provides extensive information for evaluation about the network the CS141 is connected to. All data packets are collected in a log file. After network scan, the network log can be downloaded for evaluation.

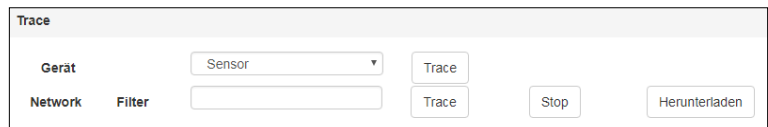

**Privacy Policy:**

Since the network scan records all traffic in this network segment the CS141 is connected to, an evaluation with a corresponding network tool can be used to find error. Furthermore, deep insights into the network traffic are available, e.g. to log the user behavior. Technicians should inform the respective responsible person before use.

To perform a network scan, click on the Trace button in the Network line. The tracer will confirm tracing activity with a short fade in.

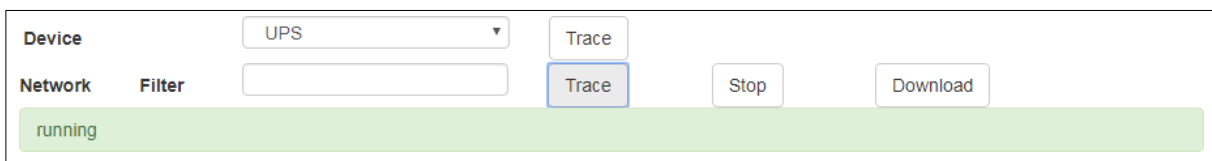

The Tracer logs packet data within the LAN segment in real-time and stores it locally on the CS141. The tracer will quit if there are two conditions:

1. A reboot (expected / unexpected)
2. By pressing the Stop button



After finishing, the data will be downloaded in the form of a packed archive for later evaluation.



**Note:**  
 The network tracer is usually very rarely needed. In seldom cases GENEREX technical support needs specific additional information to locate a problem.  
 In this case, it is recommended to start the tracer without using filtering options. Furthermore, it turns your CS141 into a powerful network diagnostic tool that lets you examine your local LAN:  
 Refer [www.tcpdump.org](http://www.tcpdump.org) to find extensive tutorials how to define filters in order to use the full potential of the CS141 as a network diagnostic system.

Data evaluation

The data analyzed via diagnostic tools such as Wireshark \*:

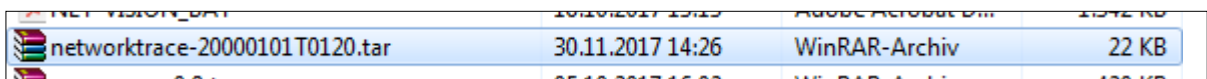

Downloaded data can be read and analyzed by special diagnostic tools such as Wireshark \*:

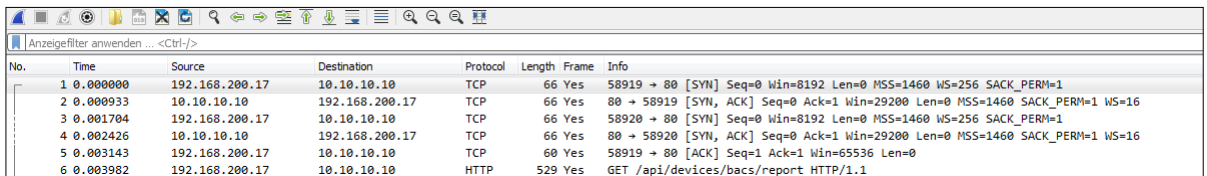

\*Wireshark is not a EXPONENTIAL POWER product. It is available at [www.wireshark.org](http://www.wireshark.org)

Delete log files

The CS141 collects and logs many data and uses non-volatile memory to store permanently:

These data can then be retrieved via a web browser or evaluated by diagnostic tools. Since the log files may contain very sensitive information about a network state, it is recommended to delete all data before re-using the CS141 Webmanager.

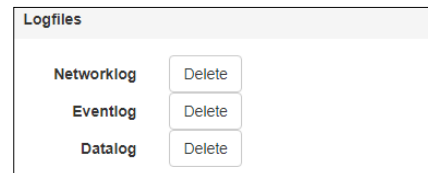

it  
tools.  
it is

Networklog

Deletes any network trace data

Eventlog

Deletes all logged data according to events

Datalog

Deletes additional data of UPS measurements.

**Note**  
 Once deleted, the logfiles are gone with the wind! Normally, the CS141 provides enough space to store the data a complete lifetime cycle. If in doubt, ensure a backup of the data files is available. Please note, there is no option to recover data on the device itself.

### Tutorial: Complete data delete routine

As a web manager, the CS141 provides a large amount of data about installed devices to ensure deep analysis in case of incidents:

- Battery data
- Sensor data
- Event Logs
- Transmit / receive confirmations
- [...]

The exact data collected by the CS141 Webmanager depends on the hardware connected to it as well as the state of configuration. However, as these data may contain both, very sensitive information about the security concept of an IT infrastructure and clearly reconstructable chain of events, a complete data deletion is recommended in case of a reorientation to new tasks.:

As an example, if the CS141 shall be sold, all user traces should be removed completely.

#### *Where are log files stored?*

In principle, these log files can be found in two places:

##### 1. The regular operating mode

The current log files are created in real time and managed accordingly. If you intentionally delete these files via the toolbox, they are lost - data recovery is not possible

##### 2. The Rescue Mode

As soon as you perform a system update in any form, the existing data and configurations are parked in the Rescue Mode as "last known good". The regular operating mode is set back to 0 and starts after a successful flashing with a new set of log files.

Due to this fact, the CS141 provides even an emergency data rescue option:

After an accidental flash, the rescue mode will allow to access log files as well as the last existing configuration since the previous planned firmware flash.

#### *Complete removal of all user traces*

To completely erase all data, first set the slide switch to center position to enable the configuration mode and its hard-coded IP address 10.10.10.10 and the subnet mask 255.255.255.0. Make sure that you have assigned a suitable IP address to your computer or enter a corresponding route to access the CS141. Carry out two flash updates in a row. Ensure both cases the checkboxes are selected: Factory default and network reset.

The first flash update transfers data and configuration from the regular operating mode to the Rescue mode and deletes all data during the subsequent flash process. The second flash update transfers the completely empty configuration from the configuration mode to the rescue mode.

#### **Note**

Type `http://10.10.10.10/update` in the browser and run the flash update after entering the current administrator password. On the second pass, the default password `cs141-snmp` is active

### Change the logo

Some companies do not want foreign logos inside their IT Infrastructure. Therefore, it is possible to change the logo shown on the upper left side.

How to change the logo

1. Open the graphic program of your choice
2. Create a new picture, maximum size is 200 X 54 PX

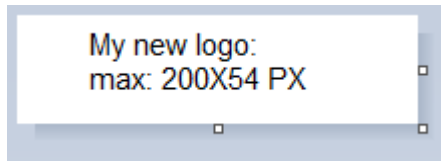

3. Edit the logo as your wish
4. When finished, save the logo with filename logo.gif – otherwise it will not work.
5. Open CS141 Toolbox:

Under Tools, you will find the configuration screen:

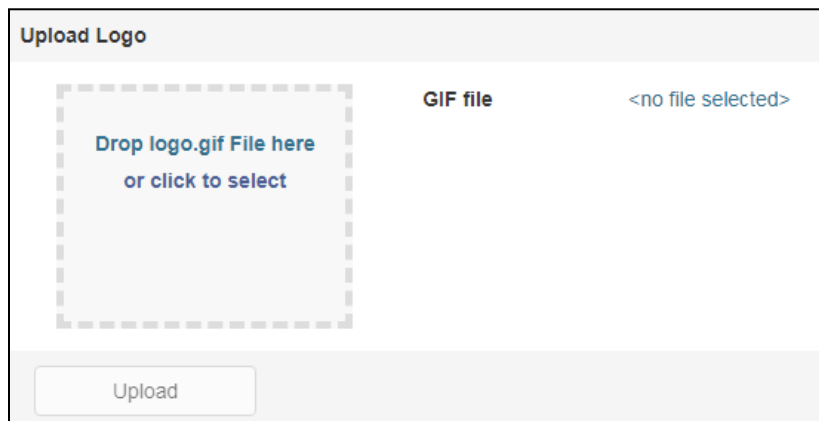

Use drag and drop to insert the new logo or click to select from a list.

6. Press Upload to insert the new logo.
- 7.

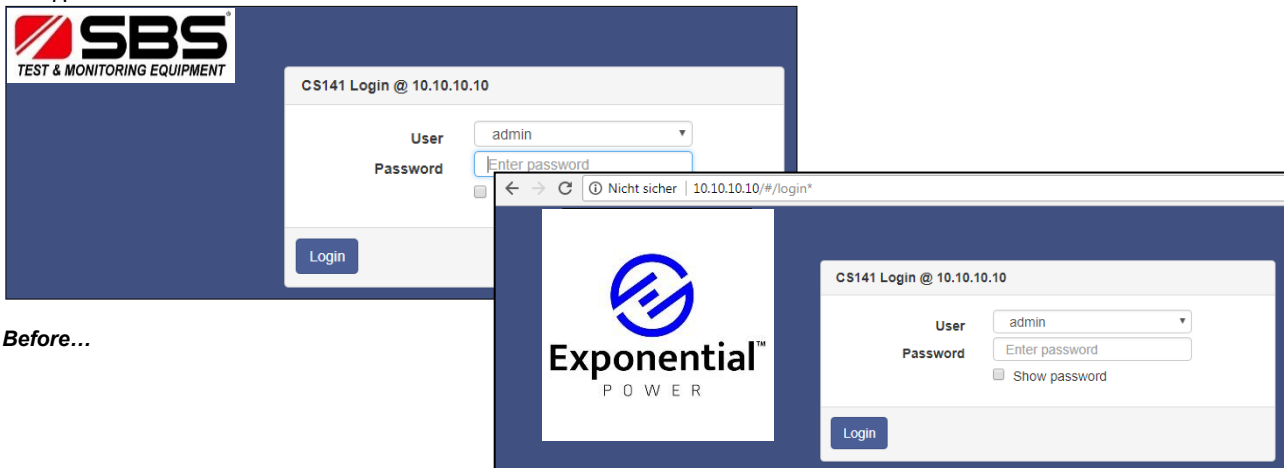

... and after

## Data backup and firmware update

For this configuration step, navigate to the following menus

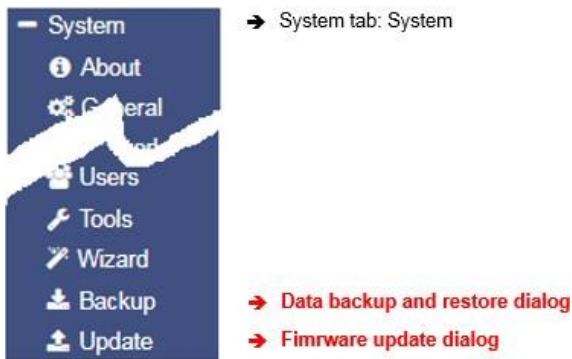

Data backup offers the option of completely backing up the current system configuration in order to quickly perform a recovery if required. The backup and restore will be done in two steps:

### Step 1: Perform a backup

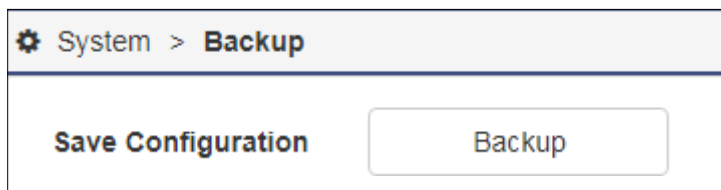

Open *Backup*. Under Save Configuration, click Backup to locally save a backup file to your download directory. Since the backup function is system-critical, CS141 asks for the valid administrator password.

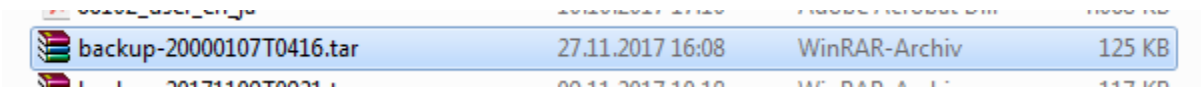

This data backup can be run with any CS141 using a similar or higher OEM firmware version. Please note, renaming the backup file is subject to some restrictions that may lead into an invalid restore procedure:

**backup-200001707T0416.tar.gz**

For changing the name of the backup file, please note the hints as followed:

- You need the packed file as downloaded.
- The area marked in red cannot be changed
- No spaces inside the file name
- No special characters

### Step 2: Restoring data

Importing a backup will use the same menu:

Use drag'n'drop to place the packed file into the box or left click on the box to open a file browser and double-click on the desired backup file. With Restore, the recovery process will be triggered. During recovery process, CS141 unpacks the file and automatically takes over as a current configuration. After completing the process, you will automatically be logged out and have to re-login with credentials according to the backup.

#### Restoring network data

**Restore network settings**

If you back up multiple identically configured web managers, you can exclude IP address settings from recovery. By doing so, previously configured IP address entries will persist while restoring all other configurations.

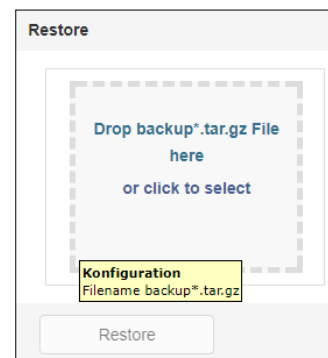

Please note that backups from a CS141 are compatible with any CS141 of the same or later firmware: If you use the backup on a CS141 with an older firmware, problems may arise. This behavior is reasoned by general improvements as well as new features older firmware versions cannot work properly with. In some cases, it is possible the backup does not work.

## Firmware updates

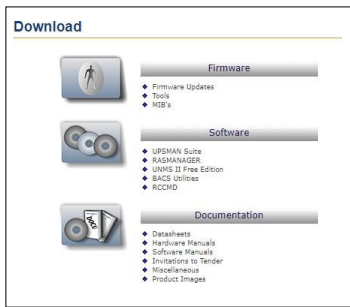

Firmware updates can be found at [www.Exponential Power.de](http://www.Exponential Power.de) by following the download area. These System updates are regularly provided for the CS141. In addition to general product enhancements such as increased stability and improvements in operational and reliability, these updates also regularly provide new features that integrate seamlessly to existing configurations.

By default, the OEM ID 69 / EXPONENTIAL POWER is preinstalled on delivery.

Deviations will result if you have purchased the Web Manager as part of a UPS from a manufacturer that comes with OEM agreements.

### Note:

Due to the fact CS141 is not technically locked, you can install the OEM version of another manufacturer at any time. In case of another UPS is used, just install an according OEM firmware version.

Under Firmware, select the version you need to use and download it to your computer. Unpacking the file is not necessary.

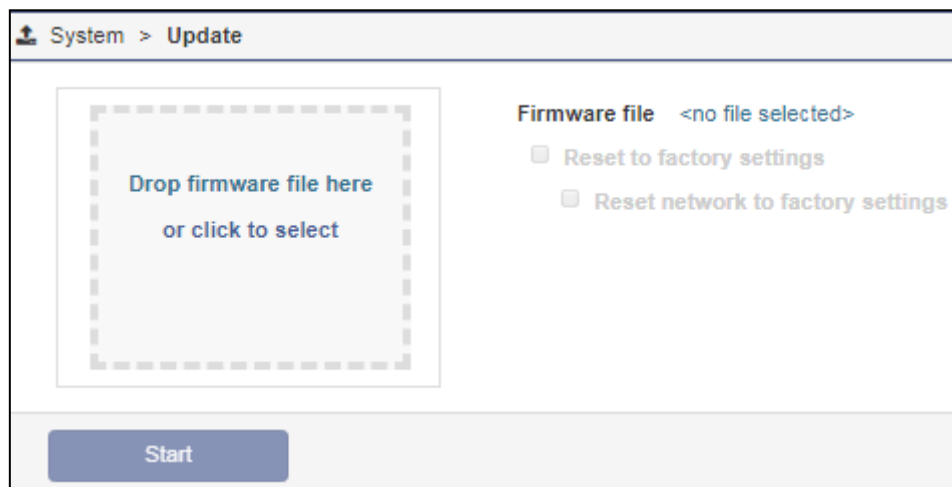

After downloading, open the web interface of the CS141 and open *Update*:

Drag the downloaded, packed file directly to the provided window. With Start will trigger the update process. Before triggering the update with Start button, you can select the following additional options:

#### *Reset to factory settings*

This option deletes all configurations during the update and returns the device to the delivery state.

#### *Reset the network to factory settings*

This option also resets the network and IP settings to factory defaults.

### Note:

These two options are independent to each other to ensure not losing the IP settings. Due to this fact a factory reset using a remote access to the CS141 is possible. Please note Reset network to factory settings needs to be de-selected if CS141 has to hold its IP settings

Since the update is interactive, please remain on the page until you are prompted to restart the device. Under system, open about menu to check the success of the update.

#### General note: Please read before flashing:

In general we recommend to use the latest firmware version:

The latest firmware version provides product improvements, new UPS models and bug fixes. Additionally, the ongoing development process allows to deploy regularly new functions. This ongoing development process includes to update core components or file systems, too.

Unfortunately, some changes need are deep inside the core system. With firmware 1.82 such a step is necessary:

1. You can always update to the firmware version 1.82 or later.
2. After the update is finished, a downgrade is only allowed until firmware version 1.82.

If you want to test the new firmware on an existing device first:

In case of a regular firmware update, the update routine will move the currently used firmware version to the rescue system as so-called "last-known-good". By doing so, you have an optional way for downgrading as long as you have not stored the firmware 1.82 as rescue mode.

How to use the rescue system can be found in the chapter "Starting the rescue system".

Although we do not recommend to use old firmware versions - if it is necessary that you need an older firmware version, please contact us: [te@Exponential Power.com](mailto:te@Exponential Power.com) - our support team will try help you in this special case.

#### Changing OEM Firmware

The CS141 Webmanager comes in two different firmware versions:

- EXPONENTIAL POWER - ID 69

OEM version of the manufacturer of your UPS

If you cannot find your UPS in the list of selectable UPSs, it may be necessary to install a different firmware.

For this, it is necessary to understand how you can detect the currently installed firmware and the required firmware:

#### *The current firmware*

You can see the current firmware by the logo in the top left corner:



Depending on the manufacturer, you will find the corresponding logo.

#### *Checking firmware version*

In the general system information, you will find this entry

<b>Hardware</b>	BACSKIT_B4
<b>Firmware</b>	CS141-SNMP V1.64.12 171213
<b>Serial</b>	1004211625 - 0030D6160377

The firmware version shows the OEM key:

V1.64 - the current firmware

.12 - the currently installed OEM version

171213- read the creation date backwards

If you want to operate the CS141 in a UPS of another manufacturer, you will find the necessary firmware on [www.Exponential Power.com](http://www.Exponential Power.com) in the download area

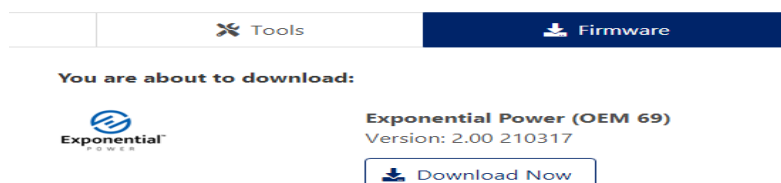

Use the Show Version Info to check if an updated firmware is available for download. Please note that unlike updating within the same OEM firmware, changing the OEM firmware requires triggering a factory default setting since features and functions may vary among UPS manufacturers.

#### Most common problems while configuration and updating

This list contains typical errors that can occur when dealing with firmware updates:

#### *Dip-switches / slide switch in wrong position*

As a result, the CS141 uses either at the configuration mode IP address or an IP address assigned via DHCP. In this case you can no longer reach the CS141. Since the configuration mode on the hardware side has the 10.10.10.10 as a pre-set, it may also cause a network error, since this IP address will be used by any CS141 as a default.

#### *Forgot manual IP address assignment or IP address set to factory default*

The CS141 boots up and tries to get an IP address. If this is not possible, it starts with the default IP 10.10.10.10.

#### *Forgotten Reboot*

Since the CS141 offers the possibility to change the sliding switch on the fly and to carries out the function via software reboot, an update can evidently trigger the change of the IP address and the CS141 is no longer accessible.

The reason for this is that the CS141 starts regularly with 10.10.10.10 and points the route to it on the local PC:

if you boot the CS141 the first time, set the sliding switch to manual mode, enter IP address data and then perform an update, only the IP settings you entered will be used. As a consequence, it seems CS141 cannot be accessed at the hardcoded IP address 10.10.10.10.

#### *Web Browser caching caused issues*

Modern web browsers use technologies designed to speed up content viewing and improving multimedia experiences:

- Speech recognition
- Auto-complete names and address data
- Automatic login into websites
- Personalized commercials
- Pre-caching files from websites
- Holding website files for faster revisit
- and many more ...

These media files are loaded into a separate browser cache to ensure the fastest and most comfortable possible web experience. The CS141 uses build-in web-based technology. If you use more than one CS141, web browsers sometimes show pre-cashed data:

Mixing identical content from different devices can cause strange or illogical error messages.

#### **Note:**

This is caused by web browsers' behavior. In this case, the browser cache must be deleted.

#### *Force https is active*

Depending on patch level and web browser used for displaying web-based content, some web browsers tend to detect this condition and automatically add the https. However, others ignore the wrong http query and return a device is not available message or react in a very strange way:

https was sometimes automatically enabled, but the https-query will be redirected to another device. In this case, browser logged your surf behavior and assumed that you meant another device that is known to use https. As a result, you enter the IP address http://192.168.3.15 and https://192.168.3.56 will be shown. At https://192.168.3.15, however, it would have been the correct CS141 been displayed.

Again, the behavior of the web browser is involved to cause some confusion. Deleting the browser cache will fix it.

### If nothing works...

The CS141 comes with two possible options if a problem needs to reinitialize the firmware or resetting the device to factory defaults.

If the CS141 does not allow a login or the interface shows a faulty display, but still can be reached regularly, administrators may try the following:

`http://<IP address>/reboot`

This option allows you to force a restart of the CS141 directly.

`http://<IP address>/update`

This option takes administrators directly to the update screen without the need for logging in

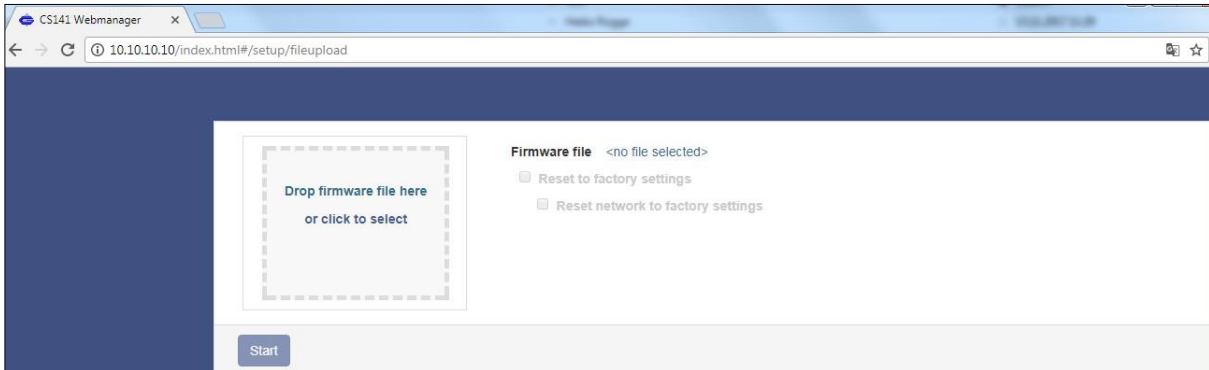

From now you can select the desired firmware package by drag & drop or by clicking the button. Please note, this function is a rescue system, the CS141 will reset all settings except the IP address. All configurations are deleted and the device is set to startup configuration.

Enter the password for the administrator account, if you are not in configuration mode.

The process starts and after successful flashing the standard login screen will be shown.

#### Note:

If you have lost the administrator password, move the DIP switch to center position. After cold boot, it is possible to flash the device directly. Enter the following line in your web browser:

`http://10.10.10.10/update`

As a consequence, the administrative password will be set to default setting.

#### Starting the rescue system

If this feature is not available, the CS141 offers second option: During flashing, the CS141 saves a complete backup including the configuration of the "last known: good".

This version can be activated by setting the following jumper:

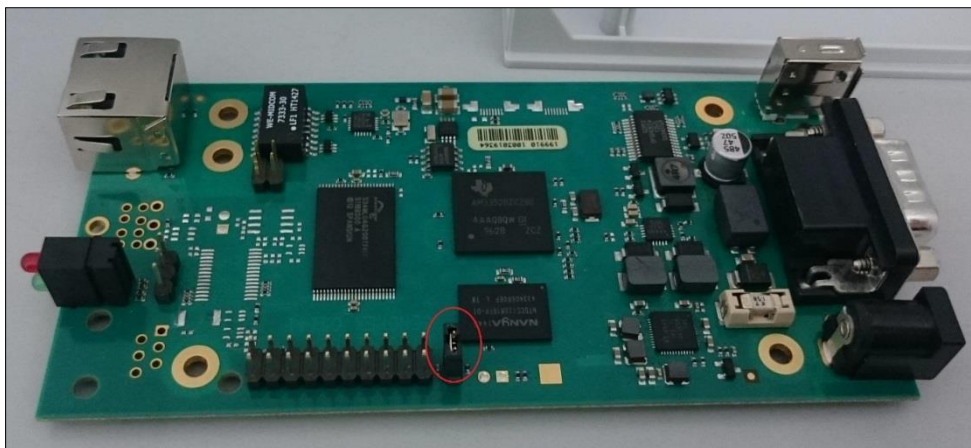

If the jumper is set and the adapter boots, CS141 will run this version as a rescue system based on the last firmware version: Inside the About menu, the firmware version will add the word RESCUE to show its current operational mode.



Rescue mode on CS141 mini

Due to its compact design, the CS141 Mini has no jumper that can be set. To activate the rescue mode, set both DIP switches to the ON position:



Run a firmware update and reset the adapter to factory settings. Please note you are not flashing the operating system of the rescue mode:

You will not see the result until you return to normal operating mode and restart the CS141.



**Exponential<sup>TM</sup>**

P O W E R



**SBS<sup>®</sup>**

***TEST & MONITORING EQUIPMENT***

## What is EQUALINK?

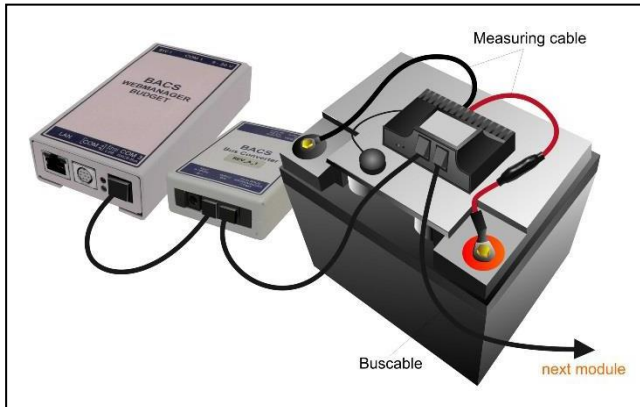

EQUALINK - the "Battery Analysis & Care System" - is the most advanced system on the market to manage stationary battery systems. It is a standalone battery monitoring and management system that can be easily integrated into your network infrastructure. With its intelligent web-technology configurable management technology, it cyclically checks the internal resistance, the temperature and the voltage of each individual battery. In addition, it can readjust the charge voltage of each battery and manage environmental readings (temperature, humidity, hydrogen gas content) as well as loads (UPS, inverters, and other devices). The Batteries are thus always kept in the optimal working range. The ongoing monitoring and limiting of the individual charging voltages of each block ensures the estimated maximum battery availability at any time. After installation, EQUALINK will significantly find a way to increase and secure the performance at all lead-based, closed and sealed

batteries (AGM, GEL, wet batteries, VRLA), nickel cadmium and lithium-based cells.

The EQUALINK system was designed for the individual monitoring and to control each single Battery inside a battery system. EQUALINK regulates the voltage symmetry during charging and provides individual scalable notification options in case of an asymmetric discharge or similar faults:

- It stops the overcharging of individual batteries and warns in case of pending deep discharges.

The problem is that weak Batteries may be damaged by unrecognized overcharging or deep discharging is now observed. Notifications in time allow counter measures before an incident occurs.

- The EQUALINK unique system architecture provides active charge / Discharge control for each Battery

The EXPONENTIAL POWER EQUALINK BALANCING distributes evenly

the voltage from the charger / UPS is evenly distributed to all Batteries. As a result, a homogeneous voltage is present across all batteries inside the system. Due to this fact, average lifetime and capacity will be increased significantly.

- Sulfation problems are no longer a creeping threat

EQUALINK EQUALIZATION minimizes the problems of sulfation through a constant trickle charge. In case the sulfation is in progress, EQUALINK can detect this as a problem and ask for further assistance by the operator in good time. As a result, countermeasures like controlled discharging or removal of sulfation can be initiated before the Battery is severely damaged.

## What is the advantage of EQUALINK?

Manual monitoring and maintenance are expensive and complex - With EQUALINK, they are no longer necessary Since the individual data of the batteries is now available, it is possible to maintain each Battery individually at any time. If the EQUALINK BALANCING repair procedure does not work on one or more Batteries or irreparable defects are detected on a battery, it is possible to change one cell before the defect has a negative effect on the neighboring cells. The precautionary replacement of all Batteries inside the system is therefore no longer necessary. By doing so, EQUALINK ensures the reliability of the battery system:

Its unique technology provides by the constant monitoring and managing of the Batteries, optimizing capacity to ensure emergency operating time.

*The data and experiences gained through our unique EQUALINK since 2004 on the realistic behavior of battery systems shows how to double the average service life time of rechargeable batteries that are installed into UPS systems and why the UPS usage differs from a single rechargeable battery usage: The estimated life of a single battery is determined by the manufacturer - As an example, he states an estimated life time for a special battery model as 10 years. Since inside large UPS systems many batteries are interconnected, the single battery behavior will change according to the number of batteries in use:*

*The number of weak batteries with negative influences to neighbored ones will increase statistically.*

*Due to this fact, the overall behavior of all batteries leads into a significantly reduced time for active usage inside a UPS - the so-called service life. Astonishingly, this active service time is usually half of the stated battery life time. With EQUALINK, it is possible to extend the life of any battery running inside a UPS to the manufacturer's stated battery lifetime. EQUALINK offers more than best economical possibilities in single battery monitoring - it provides reliable data for extensive analysis and long-term studies.*

*EqauLink systems are available in 4 versions (2V, 6V, 12V and 16V) for a range of uses ranging from small 7 Ah batteries to large stationary lead-acid batteries up to 6000 Ah.*

In addition, the EQUALINK system has a state-of-the-art alarm threshold system that is continuously under development. EQUALINK collects readings inside specially designed internal database for battery histories:

The device determines and stores individual battery values like internal resistance, temperature and voltage. With the optional EQUALINK CSxxx current sensor, the scope of measured data will be enhanced with additional charge and discharge current measurements, valuable data for comprehensive long-term analysis. Collected sensor data will be sent directly via its own bus system to the central control unit, the EQUALINK WEBMANAGER.

All incoming information will be stored and processed:

After processing sensor data, the EQUALINK WEBMANAGER provides an intuitive well-structured interface to present the measurements. In companion to the data presentation and configurable notifications, additional alarm LED and alarm buzzer ensures that the UPS will be safe during operation.

Finally, the EQUALINK WEBMANAGER has an intuitive user interface via web browser, which also contains a clearly arranged configuration menu.

**EQUALIZATION: How to maintain individual charging / discharging of Batteries**

As a continuously running background process, the EQUALINK WEBMANAGER calculates a so-called "charging voltage point" - A value each block should have at the instantaneous total voltage. If an Battery deviates from this average charging voltage, the EQUALINK WEBMANAGER sends a command to the corresponding EQUALINK module that manages the Battery. The EQUALINK Module will manage to adjust the charging voltage to the calculated charging voltage point.

As mentioned, many different values are recorded and monitored - even the average activity and the number of charging and discharging cycles. If an event occurs during the monitoring which can be classified as serious or dangerous, the EQUALINK WEBMANAGER can manage alarm notifications provided by direct network alarms as well as email, SMS, SNMP or RCCMD. If available, even an optional Modem can be used for customizable SMS alarming. In case of being operated inside a Modbus system, EQUALINK Webmanager will also serve the MODBUS format via one of the serial interfaces and / or via MODBUS over IP

**Additional Features**

Thanks to optimized memory routines, the EQUALINK WEBMANAGER is capable to record battery data for up to 3 years by using reliable 32MB internal flash memory. All stored data can be downloaded and archived:

Alarms from the Batteries or other devices connected to the UPS are logged with a timestamp - in order to ensure data and time allocation, the EQUALINK WEBMANAGER provides automatic time synchronization with free definable time servers as well as second clock inside the EQUALINK BUS CONVERTER.



Picture: typical setup of a EQUALINK

## CS141 and EQUALINK

To upgrade the CS141 card version into a full EQUALINK system, you need the EQUALINK Bus Converter



In case of your project involves larger installations with more than 50 Batteries, we recommend the EQUALINK Splitting Box. The Splitting Box allows to divide the installation into individual strings. A further application is the possibility to realize well-structured clear cabling of the EQUALINK modules.

These devices can be ordered separately, among others, via the EXPONENTIAL POWER web shop as well as comfortably worldwide via a certified EXPONENTIAL POWER partner.

*What is the difference between the EQUALINK Webmanager Budget and the CS141 in companion with a EQUALINK Bus Converter?*

First of all: both devices fulfill exactly the same functions.

The difference is that the combination of a CS141 EQUALINK and a Bus Converter is modularly composed of two separate devices, while the EQUALINK Webmanager Budget consists of a complete device: While the single device has a more compact design, the modular solution allows to separate the EQUALINK BUS Converter: Take it along while the CS141 will continues in place its monitoring and managing works.

In both cases, it is possible to connect a computer in order to use the EQUALINK tools.

### EQUALINK WEBMANAGER Kits



The EQUALINK WEBMANAGER BUDGET is the central control unit for all Batteries connected to the EQUALINK bus. The EQUALINK WEBMANAGER KIT contains a EQUALINK WEBMANAGER, all necessary cables as well as power supply.

The EQUALINK WEBMANAGER can be configured via a special EQUALINK data cable as well as via a network interface.

Each EQUALINK WEBMANAGER system includes a full-featured SNMP / Web UPS Manager on COM 1 and offers a variety of sensors for access control, temperature and humidity as well as versatile environmental sensors. Even customer-specific sensors can be used via the optional SENSORMANAGER.

### Upgrade your CS141 into a full-featured EQUALINK Webmanager:

For this configuration step, navigate to the following menu:



#### General COM port settings

Under Devices, click on the menu Setup. This will allow to activate the EQUALINK capability and is necessary for further configuration. Without this setting, the EQUALINK menu is not accessible.

#### Note:

*An easy method to figure out if your CS141 model can be used as a BACS Webmanager.*

As soon as your CS141 provides an AUX-Port, your CS141 will support a BACS BUS Converter in general. You just need to look at the ports. If you cannot access the device physically, you can take a look at the General COM Port settings. If your CS141 model does not provide an AUX port, COM3 is not available.

EQUALINK can be operated a completely standalone system - independently of your previous UPS configuration. Even it is useful for EQUALINK to know the current UPS state, it is not required. If you just want to monitor the Batteries in standalone mode, you can disable the UPS functionality by setting COM 1 from UPS to none.

The image shows a configuration interface with three sections: COM1, COM2, and COM3. Each section has a 'Device' label and a dropdown menu. In the COM1 and COM2 sections, the dropdown menu is open, showing three options: 'UPS', 'none', and 'UPS'. The 'UPS' option is selected in both. In the COM3 section, the dropdown menu is closed, showing the selected option 'BACS'.

If you want to monitor the alarm behavior of the UPS and already manage your network, let COM 1 be on UPS - EQUALINK will be operated like an additional feature. These basic settings are mandatory to be set for both - slot card versions and the external versions of the CS141.

**Note:**

The UPS with their connected batteries generally stay together!

You can not monitor a UPS and connect the BACS-monitored batteries to another UPS. The power source is not important for CS141 as long as the correct UPS is queried:

it is crucial that the charge / discharge detection is configured to UPS as well as the associated batteries.

Since the BACS Webmanager provides different possibilities to query a UPS it is possibly it is up to you to select the best power source as well as to configure the correct target. You can not use one BACS Webmanager for different Battery sites.

When saving, necessary services are started. After finishing this process, a new EQUALINK menus will be accessible:



*Hardware precondition: Connecting the EQUALINK Bus Converter to the CS141*

Even the menus are accessible, the EQUALINK Bus Converter needs to be connected to CS141 before starting configuration. Use the AUX-Port of the CS141 and the COM 3 Port of the EQUALINK Bus converter to establish a connection between the devices:



From the CS141 AUX-Port ....

... to the COM 3 port of the EQUALINK-Bus Converter

Since the cables are coded, a wiring failure should not be possible. During installing, ensure neither to jam the connectors nor to use brute force - the contacts may be damaged.

Once communication has been established between the devices, a relay will click inside the EQUALINK Bus Converter and a red LED will light up on top, followed by a buzzer.

Press Mute to temporarily switch off the alarm. You can not switch off the alarm permanently, after some time it will be automatically fall back to active state.

In addition, the upper status bar inside the CS141 web interface will show a "Communication Lost" issue - This status is normal in this configuration state since there are no modules installed or something is configured.



*Using the EQUALINK capabilities of a CS141 SC slot card*



Connect the AUX-Port of the CS141 SC with COM 3 of the EQUALINK Bus Converter. At CS141 SC, configure the COM-Ports as described. You do not need to restart the CS141 SC.

## Note

If the menu does not appear even though you have switched COM3 to BACS, your web browser may use old files stored at an internal browser cache. Modern web browsers use caching technologies to increase the display speed of web-based content: As an example they store alleged static contents for further usage or may pre-cache complete webside contents before displaying them. In this case, it may lead into presentation failures like missing links or even wrong menus if they has been moved by a firmware update.

Please clear the browser cache and press CTRL + F5 to refresh the display and the menu should appear.

Now let us talk about your brand-new, worldwide unique EQUALINK - the "Battery Analysis & Care System":



This graphic illustrates a full-featured and fully equipped EQUALINK system. Due to the fact EQUALINK is scalable it can grow with your UPS and even easily ported to a new system – if you decide to purchase a new UPS, you can take all the modules from your old EQUALINK – equipped UPS and install it on your new Batteries.

After a quick reconfiguration, EQUALINK will automatically start to learn how your Batteries work and what they really need for best performance.

### How to read and use the EQUALINK manual

Since EQUALINK is a complete stand-alone system, it can operate on it's own, too. You do not need to read the complete CS141 manual, but it will help you to understand how the menu structure works and all about the icons used. If you want to use a UPS and the RCCMDenvironment, we recommend to start with the CS141 configuration guide and than moving on to your EQUALINK installation.

#### If you have worked with the CS141 before

If you are familiar with the menus of the CS141 and know how to add a job as well as how to set up mails, mailtraps, etc. ... well, you do not really need the first part of the manual and will be able to understand and configure the EQUALINK system quickly:

- Events
- Jobs
- Mail / Mailtraps
- Discharge detection

The EQUALINK web interface is designed to provide a fast way to configure it intuitivly. And like the CS141 part inside this manual – this manual is written to explain. ...



**DANGER:**

**Please keep in mind that batteries, battery racks and current-carrying equipment may be under high voltage - there is a real danger to life when touching high-voltage components! Working with batteries need your total attentions and following the rules. „Short cuts“ are just a method to figure out if you can survive your mortal incident...**



In the case of non-expert or inappropriate handling, there is an acute danger to life when handling modern battery systems. There are also numerous legal requirements that personnel must meet during installation, operation and maintenance of electrical systems. For this reason, we ask you to read the following safety instructions carefully and consult in case of doubt experts or at least specially trained professionals:

## **Fundamentals when working on battery systems**

Make sure that the environmental conditions for installing EQUALINK is met.

An incorrect handling can lead to personal and material damage! EXPONENTIAL POWER is not responsible or liable for any direct or indirect damage caused by incorrect handling.

### Risk of explosion and fire

Avoid short circuits! Caution: Metal parts of a battery are always charged, so never put metal objects or metal tools on the battery!

### Elektrolyte are extremely corrosive liquids.

Leaking electrolytes in a battery are harmful to the health of the eyes and the skin. Heat fumes can be easily inhaled and cause severe damage to the lungs.

### Ask trained and qualified personnel only

Working with Batteries installed inside high voltage areas are dangerous and always need special attention. Especially installation and maintenance procedures should only be performed by these trained personnel or by personnel authorized by the battery manufacturer - the personnel must be familiar with the handling of Batteries as well as necessary precautionary measurements.

Non-expert staff can run into situations with acute danger to their life due to high voltage!

### Follow the legal regulations carefully

- ZVEI publication "Instructions for the Safe Handling of Electrolyte for Lead-acid Batteries."
- ZVEI publication "Safety Data Sheet on Battery Acid (Diluted Sulfuric Acid)."
- VDE 0510 Part 2: 2001-12, in accordance with EN 50272-2:2001: "Safety Requirements for Secondary Batteries and Battery Installations - Part 2: Stationary Batteries".
- IEEE Standard 450-2002: "Recommended Practice for Maintenance, Testing and Replacement of Vented Lead Acid Batteries for Stationary Application."
- IEEE Standard 1375-1998: "Guide for Protection of Stationary Battery Systems"

### **Note**

The legal requirements may vary depending on country and state. Furthermore, the current legal requirements may be adapted or even changed completely by local regimes over time to include new technologies and scientific findings or as a direct reaction of incidents dealing with a special technology:

If in doubt, contact the local authorities before determining any safety precautions for the installation or operation of a system.

### Obey the safety rules when handling electrical conductors and components

- Ensure that all electrical loads and power supplies (chargers) are switched off as well as required fuses and switches are secured before starting maintenance work. This must be done by qualified or specially trained /certified staff.
- Remove all wristwatches, rings, chains, and other metal objects before and working on Batteries until work is done and you enter secure marked area.
- Use insulated tools that are certified for the work.
- Wear insulated rubber gloves as well as rubber shoes
- Never place tools or metallic components on the Batteries.
- Make sure that the Batteries are not accidentally grounded. If the system is grounded, release the connection: Touching grounded Batteries may lead to an electric shock accident.
- Check the correct polarity before wiring a battery. Wrong polarity will lead into damaging including the possibility fire, explosion, corrosive hot gas ....

- Stuffed lead acid Batteries contain high explosive gas (hydrogen / air mixture). Never smoke and or provovate sparks near theBatteries. Avoid electrostatic discharges - wear cotton clothing and, if necessary or required by local law, ground yourself before maintenance work.
- Always wear the appropriate clothing and take care they are suited to statutory safety and protective arrangements.

Avoid areas that are not suited for battery installations

Standard modules shall not be used in case of ...

- outdoor or open space usage as well as non-water protected, enclosed spaces.
- dusty rooms or places with high levels of dust.
- in areas of high concentration of saline as well as oxidizing gases.
- the place is next to open fire, spark zones, heat sources or inside heat extreme zones.
- areas that are known for high temperature fluctuations that cannot be normalized by environmental control systems.
- areas that are known for with high vibration or mechanical movements
- areas that are known for gas concentration or other flammable substances

**Note**

In some cases, there is a small and fluently defined borderline that decides about a location is appropriate or inappropriate for installing and operating a BACS system. If in doubt, please contact the GENEREX Support Team, we are happy to advise you about the possibilities as well as environmental conditions to be met.

Just write a small mail to our support team: [te@exponentialpower.com](mailto:te@exponentialpower.com).

if you need to install EQUALINK and the area is known to deviate from a standard installation for technical or environmental reasons: EXPONENTIAL POWER offers especially insulated and sealed modules to handle these installation scenarios.

**To be noted during installing a EQUALINK**

1. *High voltage danger*

Do not open the EQUALINK sensor; Do not attach objects to the battery or to the EQUALINK modules! The EQUALINK modules and cables could be under high voltage!

2. *Magnetic fields*

Keep in mind that every live wire creates a magnetic field around it. The strength of the magnetic field depends on the current: a large If insufficient shielded, a UPS system can generate very high electromagnetic interference (EMI). Therefore, avoid the installation or operation of technical equipment that is susceptible to electromagnetic fields.

Take care for technical staff using a cardiac pacemaker - Magnetic interferences may harm regular functions and even destroy these vital devices!

3. *Trained and EQUALINK qualified technical staff only!*

EQUALINK is installed on Batteries that can be under high voltage during installation. As soon as the EQUALINK measuring and connecting cables are connected to the Batteries, they may be under high voltage, too. To prevent short circuits, ensure the system is disconnected before performing any maintenance or installation work in companion with EQUALINK cables. Since a certain order must be adhered to, special trained and certified EQUALINK technicians are required.

**Note**

Need a BACS training for your technical staff? Speak to us – our BACS training team will be pleased to advise you the best way to get a BACS certification training.

4. *Replace damaged Batteries before installing EQUALINK for the first time*

Damaged are Batteries often not determinable by a mere visual inspection. A damage can be found during a measuring the internal resistance - the higher the internal resistance, the worse the current condition of the battery.

The problem:

If a battery is highly damaged that the internal resistance exceeds maximum possible highness, the charge / discharge current will no longer be able to pass through the battery. Because the charge/discharge current must find a way it would seek the path of least resistance: The EQUALINK module. As a consequence, unplanned heat will be generated that can damage or destroy the EQUALINK module overtime. Due to this fact, do not continue and use Batteries in a battery bank that are already detected externally as defective or if the EQUALINK module measures a very high internal resistance!!

5. *Never mix different EQUALINK module versions as well as EQUALINK types of measurement cables.*

EQUALINK modules differ technically within the revisions. The according measuring cables were specially adapted to the corresponding revision of the EQUALINK module. If you mix different EQUALINK modules, it will not work in general. In addition, an unfortunate combination of different modules may lead into irreversible damages to the cables and EQUALINK modules. Before starting to install cables and modules, ensure that you do not have mixed your stock for installation:

Sort modules and measuring cables beforehand.

## **Rework, maintenance and care**

*Regularly check the measured values of the modules and the temperature development of the Batteries*

- ... during installation and during the first charge / discharge cycle

During its initialization, EQUALINK performs its own diagnostic measurements to find hidden defects that may occur within combination of used and new Batteries. Until EQUALINK has fully captured the Batteries in order to provide a reliably report defective Batteries:

As soon as unusual temperature fluctuations and unusual increases are noticed, the according battery should be replaced immediately.

- ... up to 12 hours after complete discharge until depleted

Followed by a regular discharge from a power outage, the most common "thermal runaways" occur - a massive increase in temperature on damaged Batteries that can become so hot that leads into acute fire hazard. Statistically there is the highest risk of battery failure with damage to the electrolyte within the battery can be found significantly inside a time window of 0 to 12 hours after discharge. If the temperature of the battery continues to increase after a discharge instead of staying the same or slowly decreasing, the charging cycle should be stopped immediately and the affected battery replaced.

On passing this time window, a battery pack can be regarded as stable - it can be reintegrated into the normal chain of alarm states.

*The warnings and issues EQUALINK provides should be taken seriously - Respond in good time!*

EQUALINK was designed and developed to extend the service life of Batteries in multiples. EQUALINK will not only inform you with cyclically status messages that something was wrong after deviated behavior is detected at the monitored systems. Thanks to the unique control technology combined with efficient early warning and alarm functions, EQUALINK will inform you before an incident can harm your system:

You can react before a real incident occurs that may damage your entire system.

Please keep in mind that the protected technologies behind EQUALINK will cushion battery or charge control errors over a period of time from the first warning, but will not be able to permanently compensate for real defects.

## Additional components required to assemble a EQUALINK:

### *EQUALINK Battery C-Module*



The control of the charging and discharging processes of each Battery during the EQUALIZATION procedure as well as the measurement of the actual battery state are carried out by so-called EQUALINK battery C-modules. These modules are mounted on each individual Battery. The according C module to be used in your battery system depends on the battery used and must be dimensioned accordingly.

The key figures of the available C modules are documented in the current EQUALINK datasheets

### *EQUALINK measuring cable*



This cable is used to measure the voltage and impedance of the connected battery. It is a 4-pin cable with 2 fuses in the positive cable (red) to protect the EQUALINK system against high currents or short circuits. When installing, the connection order is important: This cable must be firmly connected to the battery poles **BEFORE** connecting the EQUALINK modules:

With wrong handling, the integrated fuse is sensitive and may trigger.

### *EQUALINK bus cable*



The EQUALINK bus allows high-speed communication between all EQUALINK modules within a battery system. This cable is specially designed for use with EQUALINK only. It is shielded and calibrated against EMI to ensure communication even in harsh environments.

### **Before you start ...**

like the CS141, when using EQUALINK there are many things that should be considered before starting an installation - there are many individual installation options to be used. One of the most important thoughts coming with this context, is whether and how to extend the technical possibilities of existing systems. One of the biggest problems here is that completely different systems may have to be coordinated with one another in order to work together towards the same goal.

fact, the EQUALINK system makes it easy to be added:

It does not care whose Batteries should be managed unless different UPSs are combined to charge the Batteries - this should be avoided, because a EQUALINK Web Manager will expect one UPS for the connected Batteries is responsible. Otherwise the measurements are strange and not suitable analyses. However, as long as this framework condition is met, it would be a quite useful information if the UPS could communicate its own operating state, but it is not needed.

Due to this fact, a EQUALINK system can be fitted seamlessly into almost any infrastructure in order to manage the

*Batteries The Central task of EQUALINK inside an existing infrastructure*

In addition to the monitoring of the battery conditions, the central task is care and active regulation of the Batteries during the complete charging / discharging cycle. Thereby EQUALINK takes into account the needs of each individual battery in relation to the overall system in order to ensure improved lifetime as well as maximum performance if an emergency situation occurs.

For the operation of EQUALINK, it is not important to know UPS that will charge the Batteries or which discharge circuit will be used - as a standalone system, EQUALINK can detect the basic system states with its own sensors inside each EQUALINK module:

- charge status
- discharge
- trickle charging status

The following installation examples may give you an insight overview about installation possibilities:

### Installation example 1: EQUALINK as a standalone system

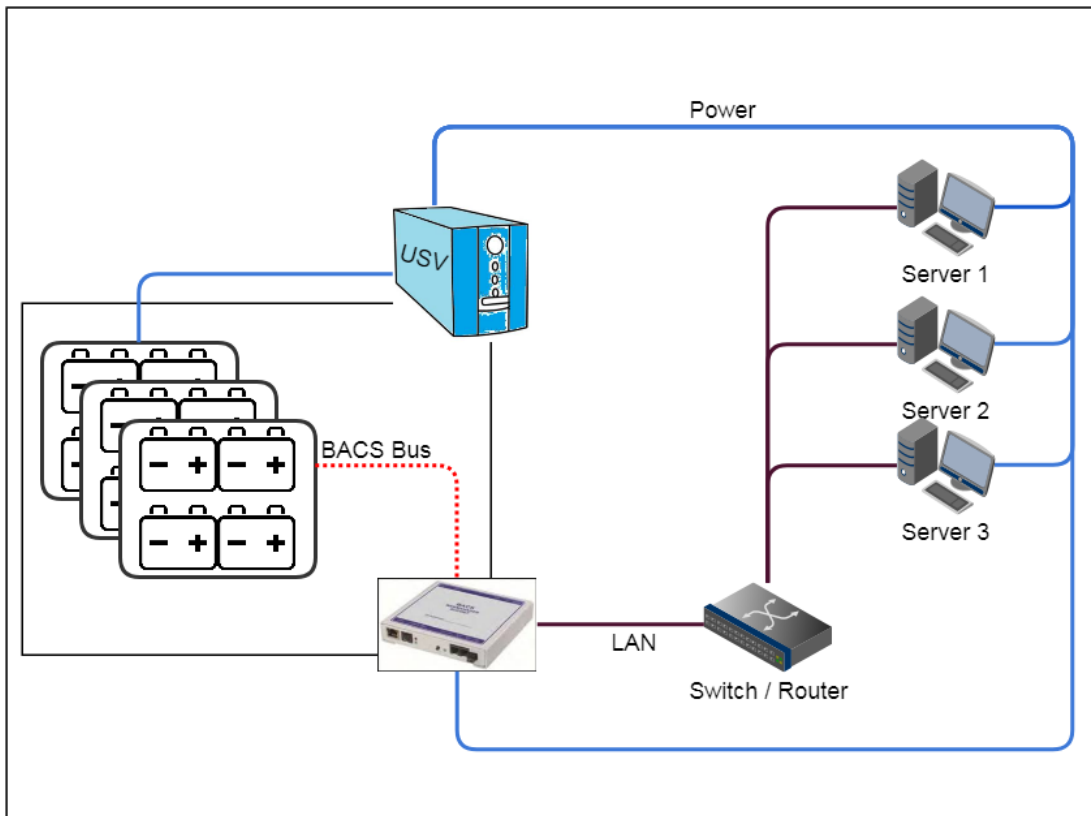

EQUALINK is not able to get system states from the UPS and is limited to the core task of monitoring connected Batteries and regulating charging cycles. The sensors of the EQUALINK modules, which are individually connected to each battery, can detect charging / discharging cycles and provide the necessary data for the control to the EQUALINK. If individual Batteries with deviations become noticeable, the EQUALINK Web Manager can automatically inform about this battery condition before a dangerous incident occurs. The disadvantage is that the general UPS functions and system status are not available:

EQUALINK can detect that the Batteries are discharging but fails to inform about the reason, why this happens.

**Installation example 2 – the complete solution: BACS is connected to the UPS via RS232**

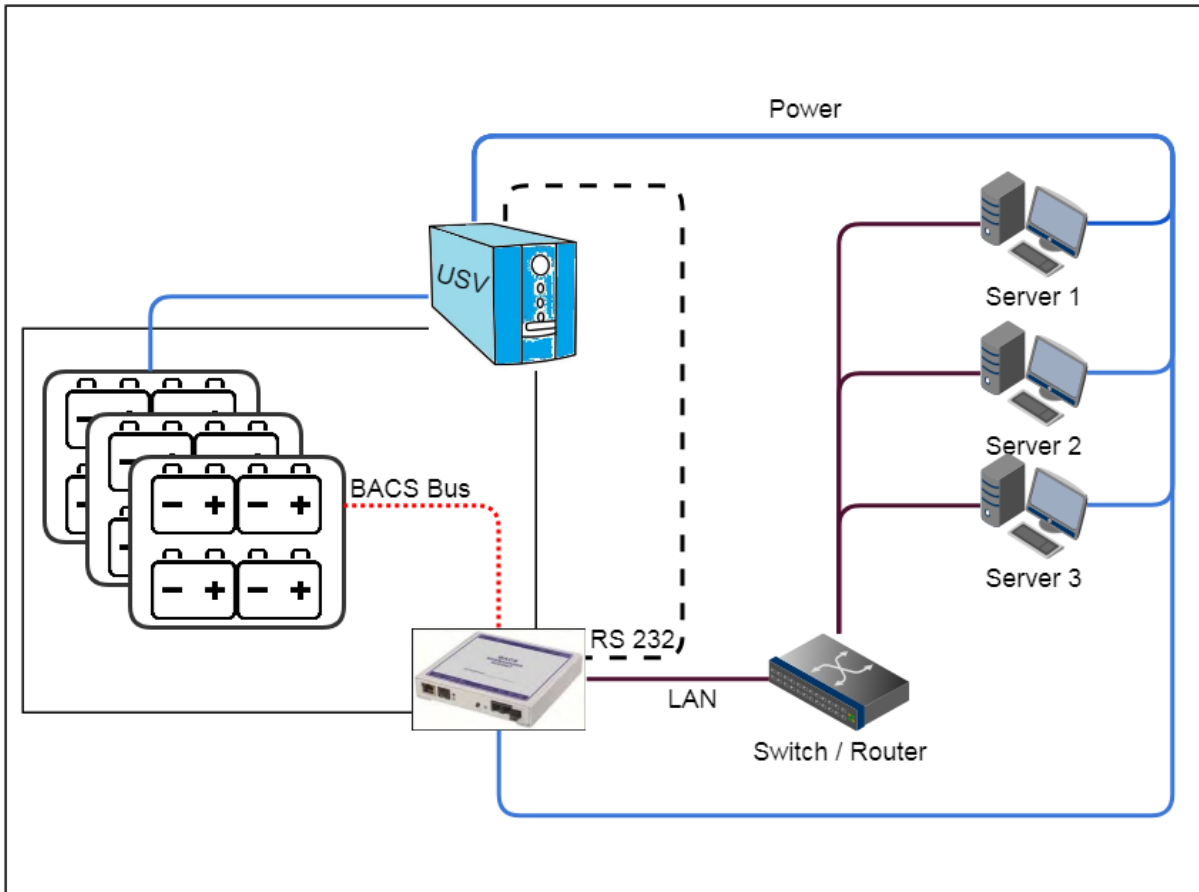

The EQUALINK Webmanager budget is connected to the UPS via the RS232 interface. The EQUALINK modules are supervised by the EQUALINK Webmanager budget. With this solution all options of EQUALINK and the CS141 are available:

- Extended UPS management
- Freely configurable emergency behavior
- Connection of external sensors
- Emergency server shutdown management
- External Input / Output management

While the UPS monitoring is fully featured, the EQUALINK Wemanager can handle complex jobs according to system events to protect the entire IT infrastructure, the integrated EQUALINK system protects the Batteries from dangerous charging currents to ensure a reliable and solid emergency power supply.

The EQUALINK Webmanager budget is an all-in-one solution for your entire network.

### Installation example 3: A modular solution that grows with your IT infrastructure

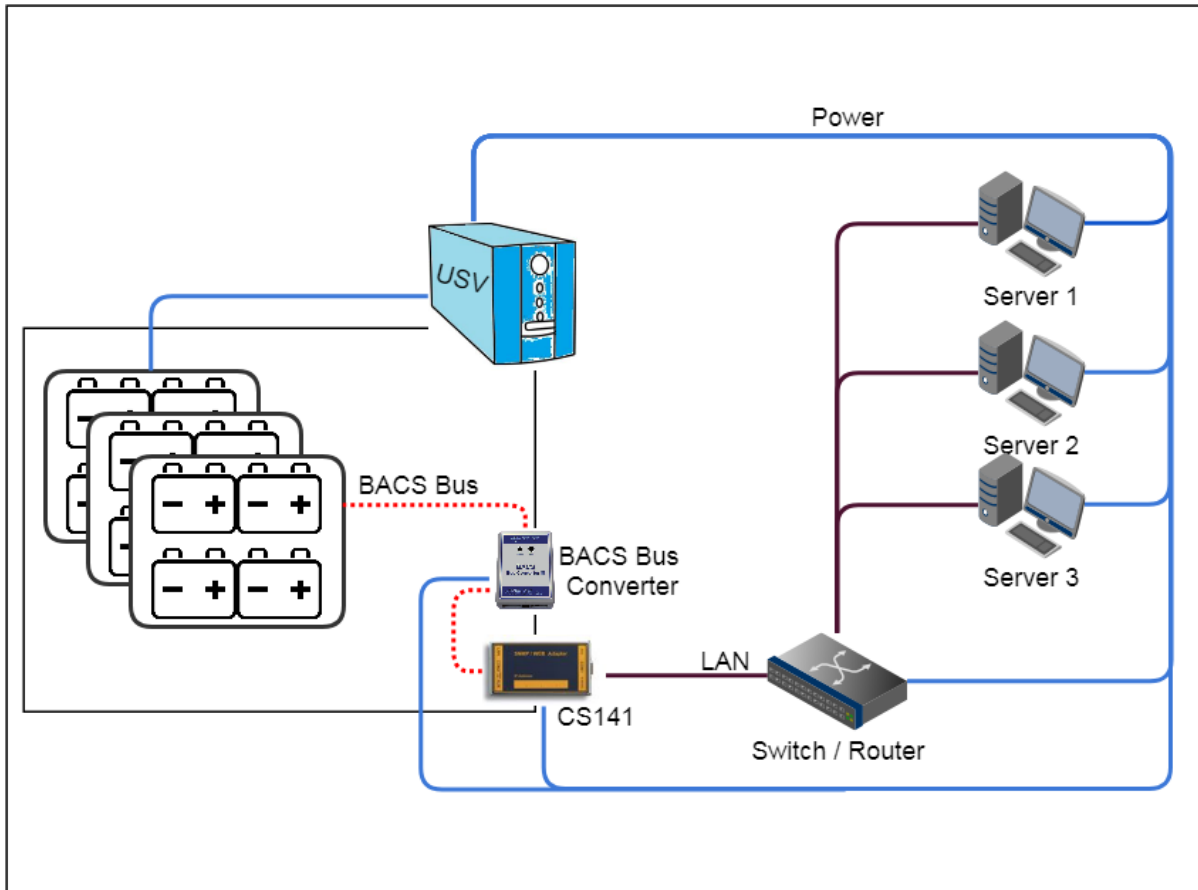

The modular EQUALINK solution provides more than just installable in case of realigning by installing a new UPS controlled emergency power solution. The modular version can be installed as a UPS manager, and then grows with the tasks even to a fully featured EQUALINK system that always fits to your UPS. As the modular installation example shows, a EQUALINK bus converter is set between the EQUALINK modules and the CS141 and activate the according COM Port inside the CS141. The CS141 will start the EQUALINK capability and provide all menus of a full-fledged EQUALINK System.

The EQUALINK Bus Converter is needed to establish a communication between CS141 and EQUALINK modules. The peculiarity here is that you can "reuse" already purchased parts, which minimizes the acquisition costs for a full-fledged EQUALINK system.

The existing UPS configuration with the alarm behavior will be enhanced by battery monitoring and management capabilities.

#### **It is up to you to decide ...**

If you prefer the CS141 as a slot card or as an external box - once the CS141 provides the AUX interface, it can be upgraded to a BACS system.

With BACS, you can plan your emergency power solution and adapt it to future trends as required.

**Installation example 4: The LAN SNMP solution – if you need UPS information without a direct connection**

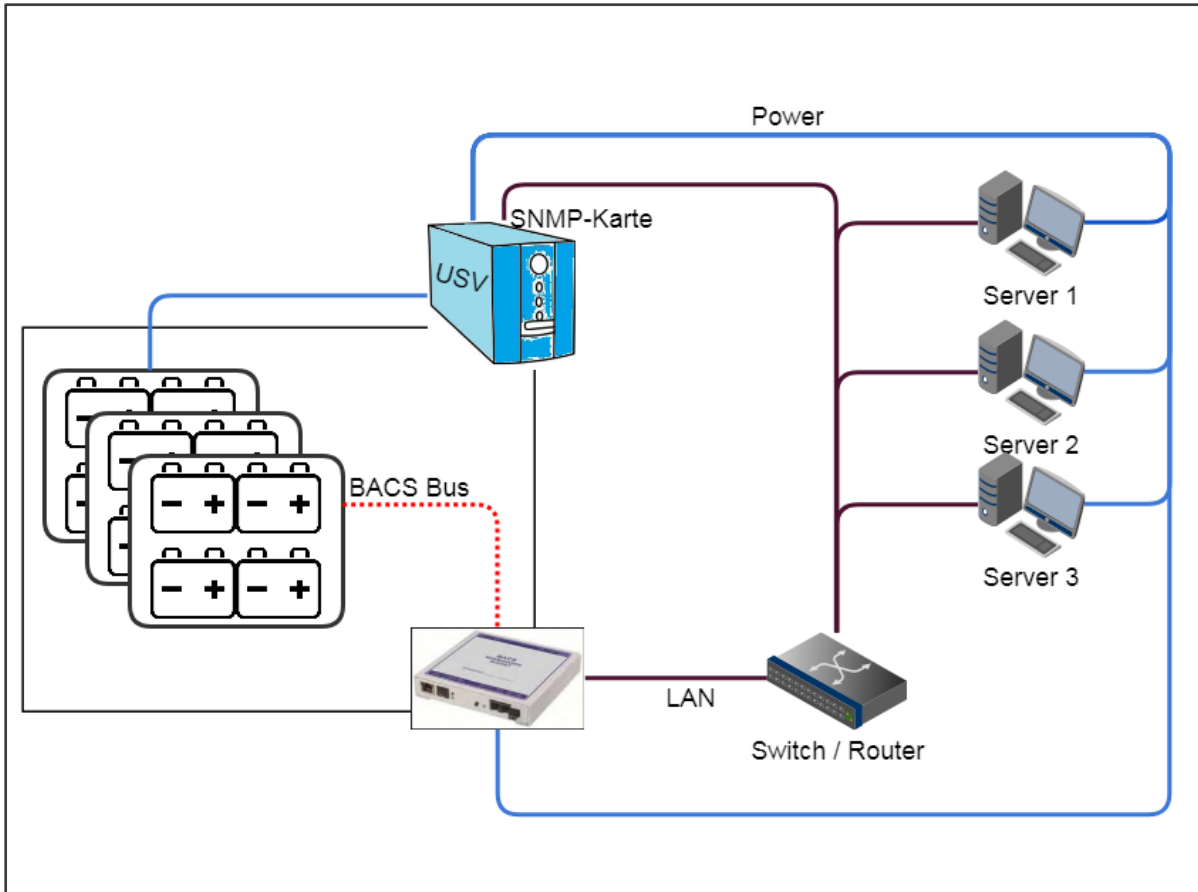

If you have read the CS141 manual, you will notice this feature at the latest at this point:

Unfortunately, some UPS models are not compatible with the CS141. Causes are, for example, that the interfaces do not exist or are otherwise occupied, existing slots of the UPS have a different design or simply the manufacturer wants to use their own system cards. If your UPS uses its own SNMP card or a similar solution, you can use the UPS settings in the EQUALINK Web Manager to query the signals via SNMP and manage all UPS functions based on this data - each CS141-based model provides this feature.

Since EQUALINK can use this UPS information as "Discharge Detection", this data is not only interesting for general monitoring, but also a reliable means to detect the current UPS state:

All you need to do is:

- Open UPS configuration dialog
- Select RFC 1628 smart interface as UPS model
- Enter IP address of the target SNMP card
- Enter SNMP v1 / 2 / 3 credentials
- Configure an according SNMP user at the target card.

The SNMP card will be queried by the CS141 / EQUALINK Webmanager budget and presented at the UPS monitoring screen.

**Note**

Yes, this feature can be used with the predecessor CS121 or an existing CS141 that is already installed but does not provide an AUX port, too – if the BACS Webmanager cannot be fitted directly to the UPS, you may use this powerful feature to adapt the BACS Webmanager fitting to your existing UPS solution.



## **The BACS Bus topology**

As well-known from network technology, there are always different ways to connect nodes and devices with each other. You need to choose the best solution for the according task and take care not to connect all nodes in a way to set up a network short circuit...

When connecting EQUALINK modules, there are less things to be obeyed - the wiring of the EQUALINK modules follows two simple rules:

*Rule 1: Each ID can only be assigned once*

One single Strain:

On delivery, EQUALINK module and EQUALINK sensors use the basic ID 0. When the EQUALINK Web Manager calls the address 0, all modules are addressed. During initialization via EQUALINK Programmer, the individual EQUALINK modules receive a single unique ID. This ID is once inside this EQUALINK installation. The module installation order does not follow the according row of address ID's: After initialization, the EQUALINK Web Manager queries individual addresses and the addressed module will respond accordingly.

Two or more strains:

Inside the strain, the ID's have to be sorted by a specific order. Between different strains, the pool of numbers must be sorted:

Strain 1: Module-ID 1 – 10  
Strain 2: Module-ID 11 – 20  
Strain 3: Module-ID 21 – 30

Never mix ID module pools between strains!

*Rule 2: Obey the maximum cable length*

The better the signal, the more stable the entire EQUALINK system will finally work

*Rule 3: Obey magnetic interferences*

Any live wire produces a magnetic field that affects other metallic objects and conductors. Although the EQUALINK cables are specially shielded against magnetic influences, the installation site can strongly take effect to the quality of the data signal. If you have a lot of interference, test for these magnetic interferences.

*Connection examples*

In general, EQUALINK does not tell you how to connect all modules each other - a structured wiring method will help you to do maintenance work as well as finding problems during installation. Furthermore, well-structured connection methods will help to improve reliability when operated. Due to this fact, there are some hints you should need to be before wiring. Both, the EQUALINK Bus Converter as well as the EQUALINK Webmanager Budget provide two ports for a EQUALINK bus. The possibility to select the appropriate installation type allows different setup scenarios

### 1. The classic ring topology:

The advantage in the ring topology is a high reliability:

The EQUALINK webmanager can use different cable routes to query a EQUALINK module. The target EQUALINK module can answer the same way. Should a cable fail, there is a second redundant connection that can compensate this for some time. The entire system is still fully operable.

A disadvantage of this design is that the arrangement of the Batteries in must meet certain characteristics, since the first and the last battery must be connected to the EQUALINK Web Manager, otherwise the ring can not be closed.

Furthermore, you need to stop at the maximum length to reach the last module in a row from both sides:

If there is a problem with the first cable, the signal needs to be routed through the last module to the first module. If the maximum length is exceeded, it will not work.

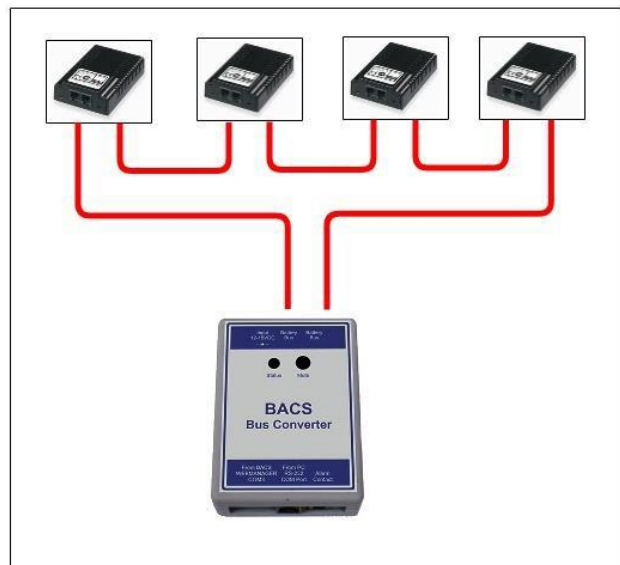

## 2. The classic star cabling:

With this topology, the bus cabling runs in different directions from a central point. it advantage is the more flexible design of the wiring and the resulting usability of premises.

Since you are not bound by certain conventions, the Batteries can be arranged flexible and adapted to the environment:

Each single strain may use the maximum available length.

Due to the fact, a star uses a single line connection type, a cable problem will lead into connection lost alerts.

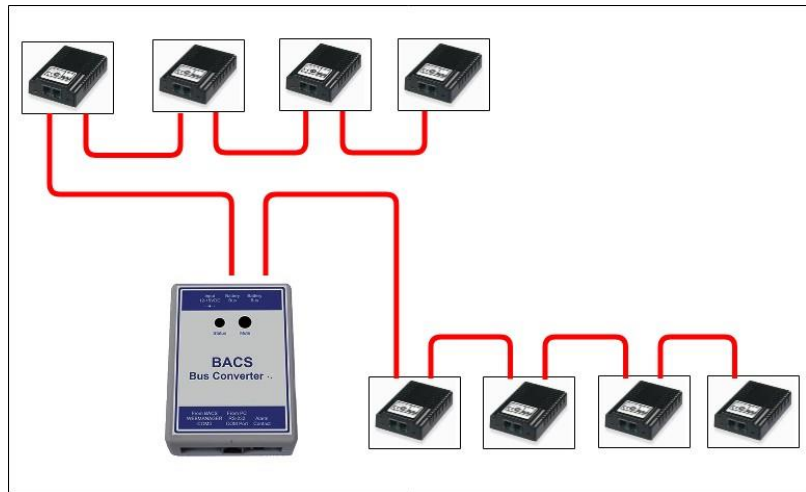

### The Splitting Box

A good tool for a well-structured cabling is the separate available EQUALINK splitting box. This box allows splitting a cabling strain into different smaller strains to realize well-structured cabling and to avoid loss of signal due to the longer cable increasing resistance:

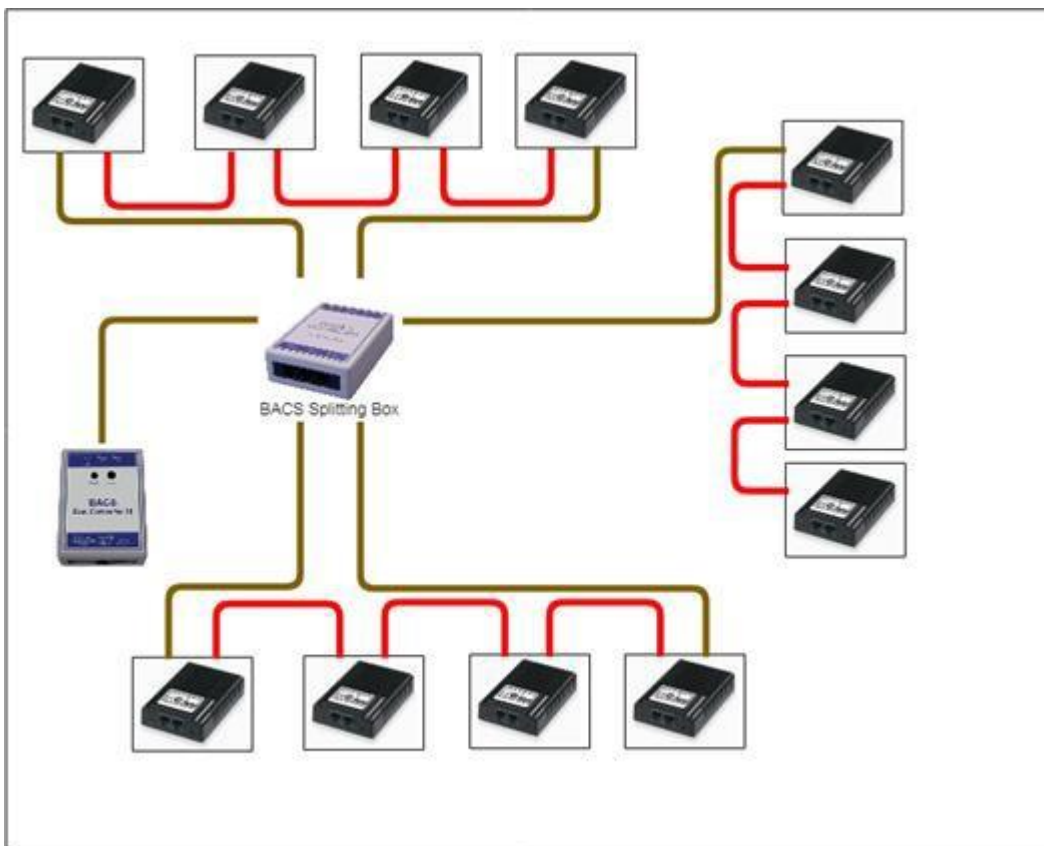

Each box provides six ports and allow several configuration methods. In this example there is a ring-topology with 3 strains – but finally it is up to you how to set up the wiring:

- Ring topology
- Star cabling – connect up to 7 single strains
- Both off hem – two ports for a ring two ports for the EQUALINK webmanager, 4 ports for single strain
- Mixed up – Port 1 of the EQUALINK webmanager for starting a ring, one port for the EQUALINK Splitting box, at splitting box 6 Ports for single strains and one port to close the ring from the EQUALINK webmanager, ...

Only the use of one single splitting box will enhance you options to connect EQUALINK bus cables.

## How to use more than one BACS Splitting Box

The EQUALINK splitting box is a flexible device. With this device, it is possible to:

- Create partial redundancies
- Create partial ring cabling
- Create ring cabling with different splitting boxes

This flexibility allows technicians to be structured as well as flexible about the locations and technicalities of a EQUALINK installation to maximize reliability:

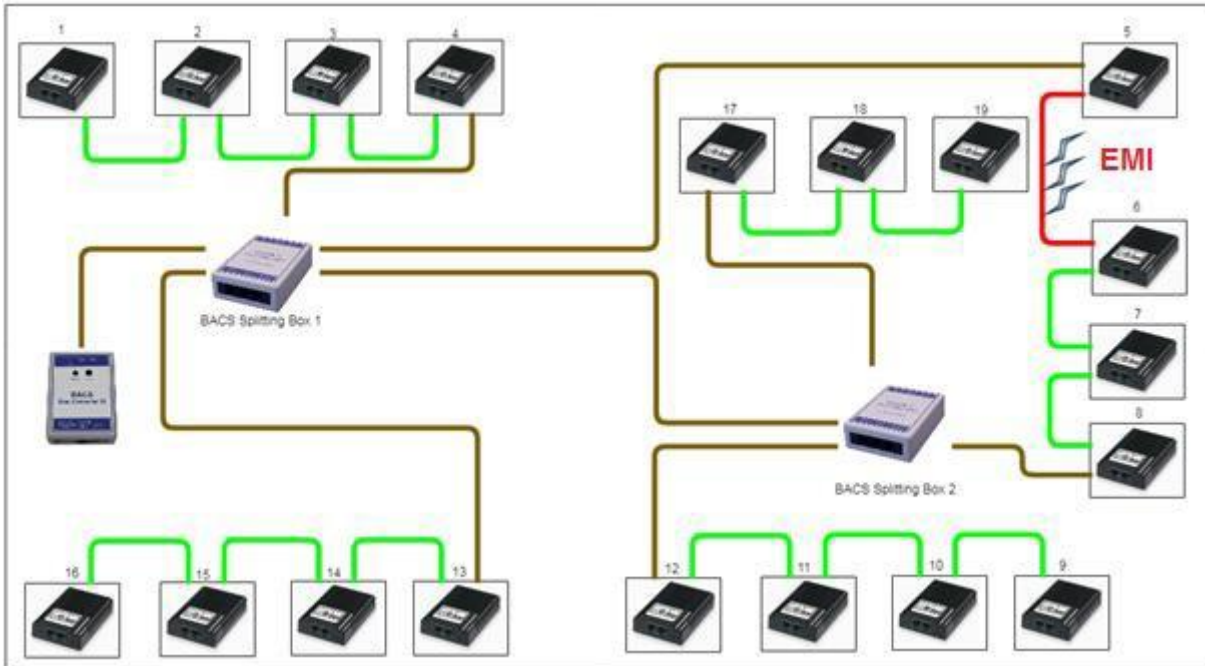

This installation example shows a combined bus cabling method:

Due to EMI irradiation, the data line between module 5 and 6 is compromised, which leads to sporadic failures. As a consequence, EQUALINK would have problems with modules 6, 7 and 8, as these modules are subsequently connected via a data line. Therefore, modules 5-8 were connected via a second EQUALINK splitting box, creating ring cabling.

Even if EMI interference would compromise the data line between modules 5 and 6, the EQUALINK Web Manager would reliably reach all modules and report no errors.

Side effect of this topology:

The EQUALINK Splitting Box 2 is connected directly to Splitting Box 1. If this connection is lost, Splitting Box 2 would automatically try to route the signal via the EQUALINK wiring of the modules 5 - 8. Without EMI it will work properly. Therefore, the modules 9-12 and 17 - 19 are closely connected to the Web Manager via ring cabling, even if it does not seem to be at first view

### Note

The BACS Webmanager is the central unit that controls the monitoring and control. If possible, use a ring topology to ensure the best possible connectivity and reliability. The BACS bus is designed to exclude a network short-circuit and ensure any number of redundancies - nevertheless, structured cabling is recommended for maintenance and traceability of an installation.

# Technical data of the BACS Splitting Box

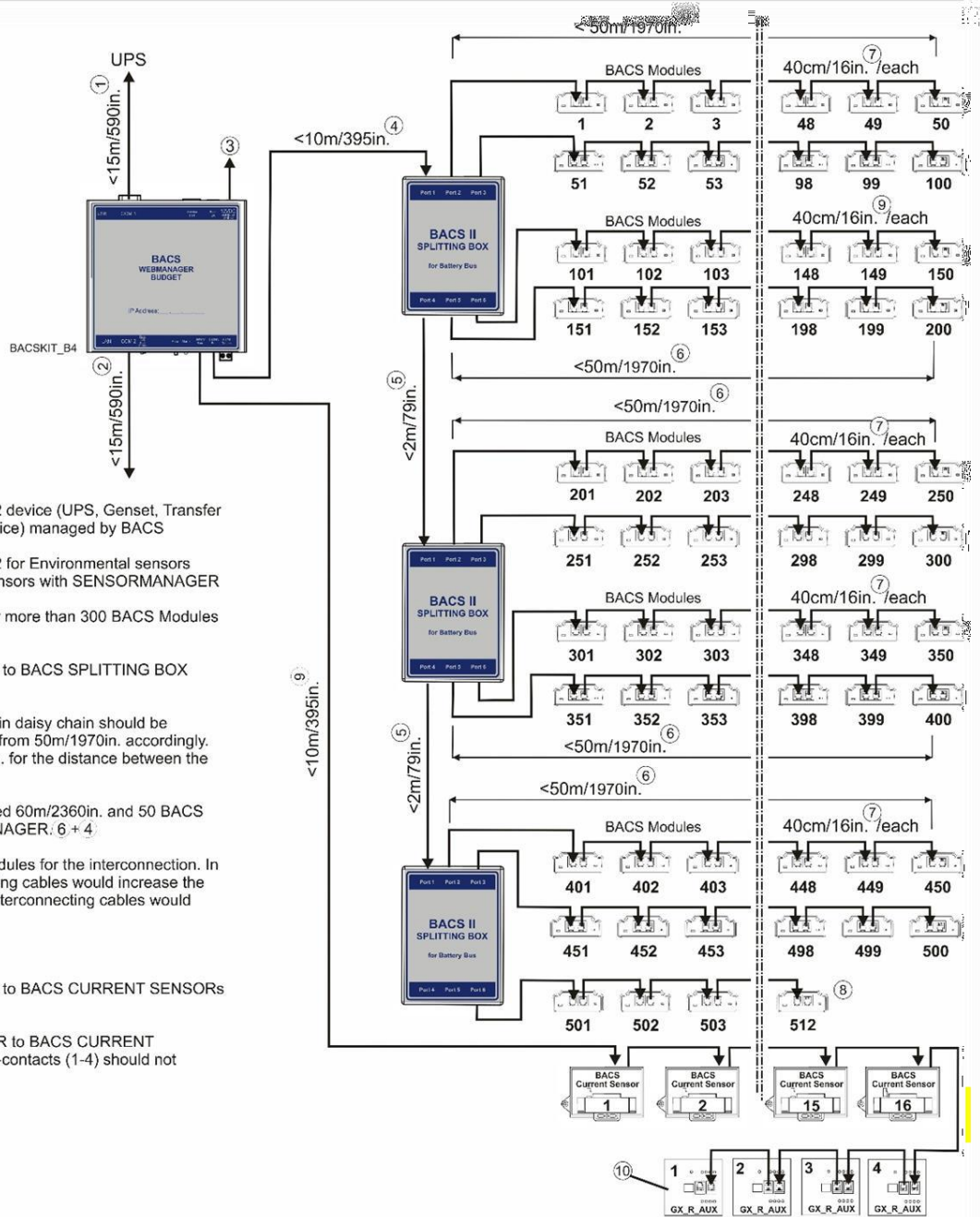

1. Max. distance 15m/590in. to COM 1 RS232 device (UPS, Genset, Transfer Switch, Charger or other battery-powered device) managed by BACS
2. Max. distance 15m/590in. to COM 2 RS232 for Environmental sensors (SM\_T\_COM, SM\_TH\_COM) or 3rd Party Sensors with SENSORMANAGER
3. Power Supply 12V/2A (UPS protected). For more than 300 BACS Modules a 3A Power Supply is required
4. Max. distance from BACS WEBMANAGER to BACS SPLITTING BOX should not exceed 10m/395in.
5. Distance between BACS SPLITTING BOX in daisy chain should be <math><2m/79in.</math> – or shorten the total length of bus from 50m/1970in. accordingly. (Eg. reduce to 40m/1575in. to gain 10m/395in. for the distance between the 2nd BACS SPLITTING BOX)
6. Total Length of a BACS bus must not exceed 60m/2360in. and 50 BACS Modules, measured from the BACS WEBMANAGER:  $6 + 4$
7. BACS bus cable length between BACS modules for the interconnection. In this example 40cm/16in. Shorter interconnecting cables would increase the distance of 50m/1970in. accordingly, longer interconnecting cables would shorten the distance of 50m/1970in.
8. Max. number of BACS Modules is 512.
9. Max. distance from BACS WEBMANAGER to BACS CURRENT SENSORS should not exceed 10m/395in.
10. Max. distance from BACS WEBMANAGER to BACS CURRENT SENSORS (1-16) and BACS GX\_R\_AUX Dry-contacts (1-4) should not exceed 50m/1970in. in total.

## BACS – Installation with 2 or more BACS Webmanagers

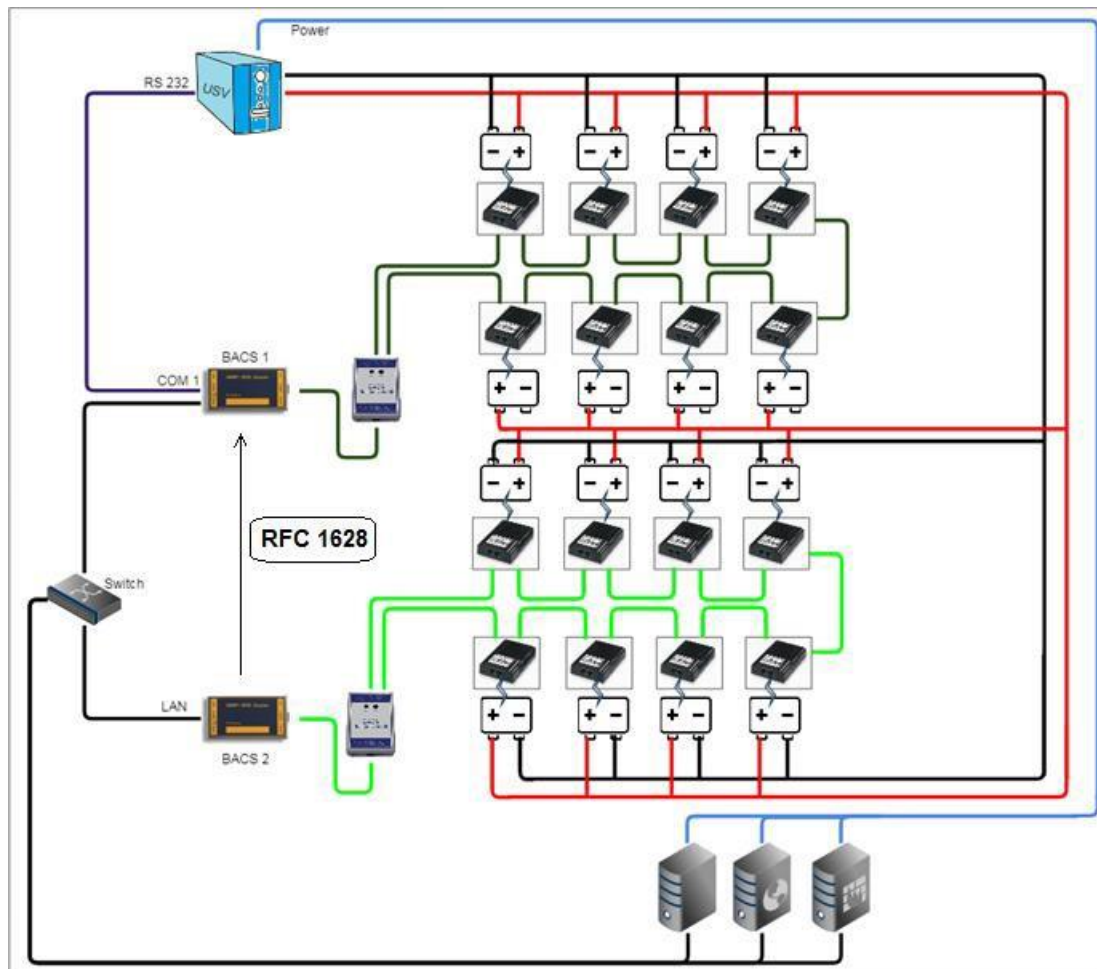

The number of Batteries a single EQUALINK installation supports is limited to 500 Batteries. If more than 500 Batteries are in use, EQUALINK supports the installation and coordination of several EQUALINK webmanagers. In this installation example, two EQUALINK systems were coordinated with each other to jointly manage a large battery field.

Following this installation method, there are two basic things you need to consider:

- 1- Each EQUALINK Bus has to be run with it's own EQUALINK

Webmanager

Two EQUALINK web managers are not allowed to address and govern the same EQUALINK modules - they would interfere with each other. If you have more than one EQUALINK Web Manager in use, make sure that each EQUALINK network forms a closed system for itself. The EQUALINK bus itself will not work with an uplink to two different EQUALINK Webmanager.

- 2- All Batteries inside a EQUALINK installation has to be charged / used by the same UPS

As soon as the Batteries of different UPS systems are charged and discharged, they are completely independent UPS systems. It would be an invalid battery condition if e.g. A UPS indicates a discharge state, but the monitored battery is actually charging because it belongs to a completely different UPS with it's own circuit.

In this example one UPS loads all Batteries. To unleash the full regulation power of EQUALINK, EQUALINK 1 is connected to the UPS via RS232 cable while EQUALINK 2 receives UPS data from EQUALINK 1 by LAN via the RFC 1628 smart UPS interface. By doing so, a numerous redundant reactions and very complex configuration options are possible to think about.

### Note

Each BACS Web Manager is also a complete system for UPS and building monitoring. Since an emergency can be more than just a power outage, you can control all installations like lifts, access control, lights, lifts, etc... A CS141 based system can perform emergency management of an entire IT network, co-ordinate communication with parent and child systems, and much more.

With each additional web manager that joins your network, connectivity, control, and monitoring will be increased.

**BACS – Installation with 2 or more BACS Webmanagers**  
*EQUALINK – Installation bei einer USV mit Mittelabgriff*

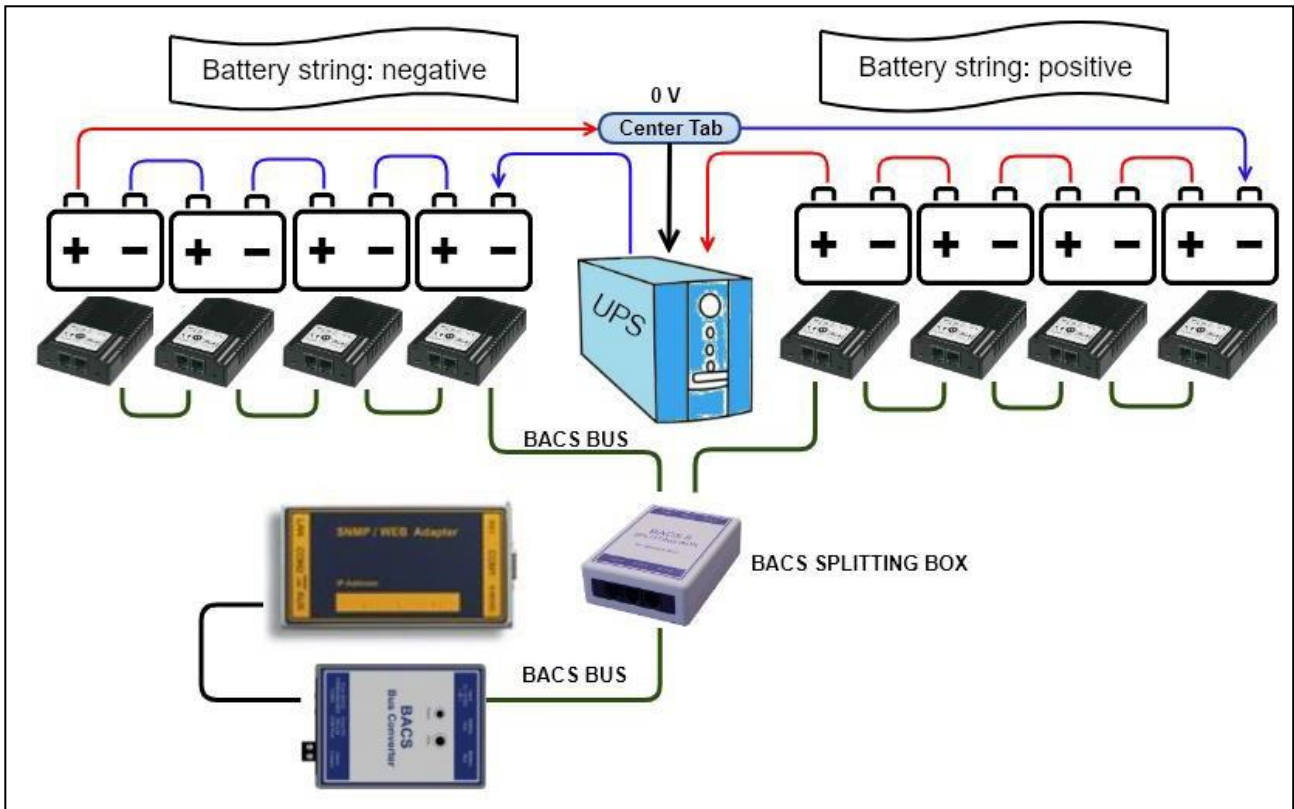

Modern UPS systems use a center tap, which increases the efficiency of the entire system.

Since the two battery strings are arranged symmetrically, problems with the Batteries can be recognized, among other things, by the fact that the voltage difference in the center tap is ideally 0.0 volts.

*So überwacht EQUALINK die Strangspannung bei Mittelabgriff*

While the UPS usually does not notice at this early point that a general problem could be present, EQUALINK can not only determine what caused the imbalance on the basis of the individual consideration of each individual battery, but also warn in good time before all the Batteries start charging due to incorrect charging behavior UPS can be affected:

EQUALINK actively intervenes in the charging process and regulates each battery individually, so that the ideal condition of 0.0 volts can almost be achieved at the center tap.

The result of this is that the drift of the voltage is not just be displayed as a general phenomenon, but also the reason be spotted and investigated by evaluation of the current data situation.

**Note:**

When using BACS, each battery is looked after individually and any problems are reported - since the quality of the charging current is checked regardless of the active control and the measurement results, monitoring the string voltage in a UPS with center tap provides additional protection:

In case of doubt, conclusions can be drawn about the general system status of the UPS itself. Since the individual results can be evaluated by using the professional analysis software BACS Viewer, all information about UPS and for each individual battery is available.

## Preparing Batteries

Before you can connect the EQUALINK modules, the Batteries must be prepared. In addition to the general safety guidelines for work on live components and live cables, please note the following when handling the EQUALINK power cables: Each EQUALINK measuring cables provides an own fuse, integrated in the positive pole of the cable.

As soon as faulty currents leave the tolerance range, these fuses trip in order to interrupt the contact between the EQUALINK module and the associated battery. By doing so, the EQUALINK module will be protected from damage.

Please note, this fuse is not designed to be removed or repaired. The entire cable needs to be changed during maintenance work at the according battery:



Short circuits inside large battery systems are very dangerous depending on battery type, it can lead to explosive gases, escaping high corrosive acids as well as acid gas. It may also lead into fire fed by chemistry.

Never try to replace or repair the fuse!

During initial installation, please obey the following:

Once load is connected to the EQUALINK cable, current will inevitably flow when as soon as contact with the battery poles is established. During installation work, an unnoticed repeated brief touching of the battery poles can may trigger fuse while connecting to the battery. In some cases, the fuse will continue working for the moment but is permanently damaged and will trigger short time later. For this reason, there is an installation row to be followed:

First connect the cables to the battery poles and then connect the EQUALINK modules to the pre-coded connector. This will prevent such an internal damage at the fuse.

Since battery connectors may vary depending on model and manufacturer, the basic connection procedure is always the same

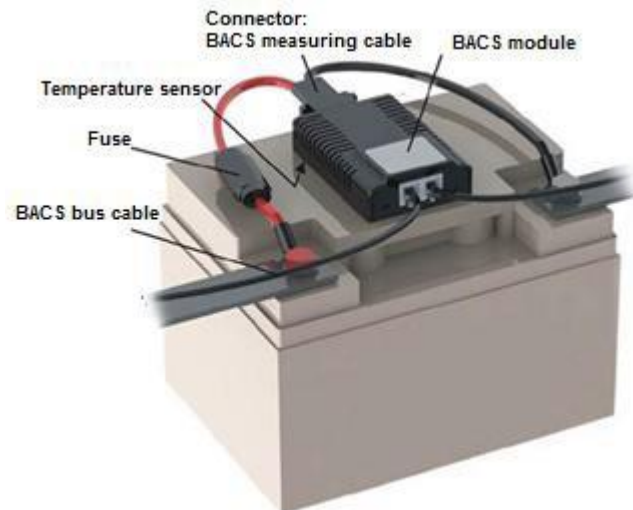

procedure:

Connect the EQUALINK measuring cables to the poles of the battery. Ensure not reversing the polarity of the cable, the fuse in the measuring cable will be triggered immediately and the cable needs to be exchanged:

- |              |                              |
|--------------|------------------------------|
| Red cable:   | Positive pole of the battery |
| Black cable: | Negative pole of the battery |



When fitting measuring cables, keep in mind to grant enough space for the later installation of the EQUALINK module:

As the EQUALINK module among other things provides a built-in temperature sensor the module must be attached to the battery in away that the internal sensor is placed about 1-4mm from the battery case. By doing so, the module will be able to measure the air temperature close to the battery.

### Connecting a BC5 measuring cable to terminal ports of Batteries at 6V - 16V

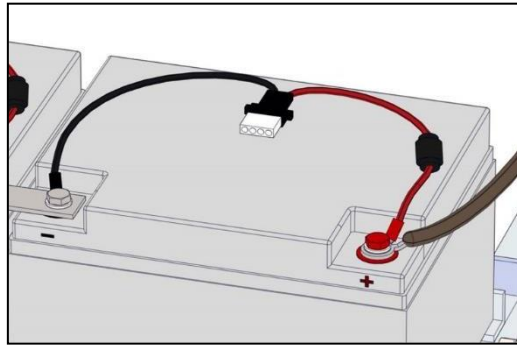
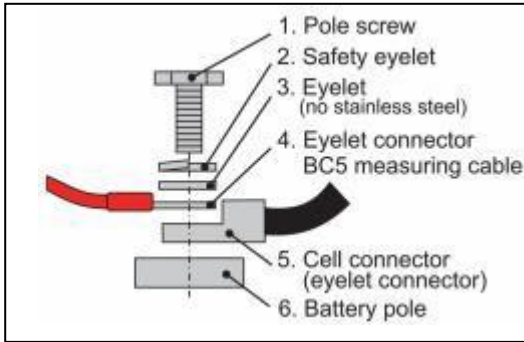

When connecting the battery terminals, please observe the torque values specified by the manufacturer, as otherwise you may damage both the battery and the terminals. Furthermore, please refer the manual of the battery model - depending on the manufacturer, there may be design differences to the installation examples in this manual.

### How to connect the BC4B test cables to 1.2V - 2V bipolar Batteries

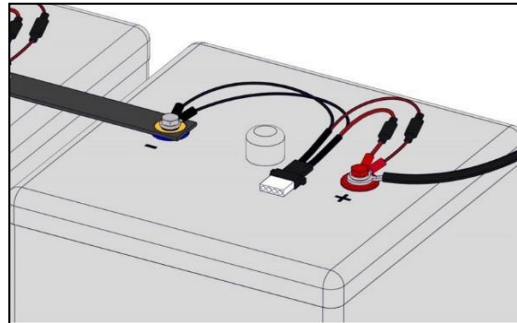
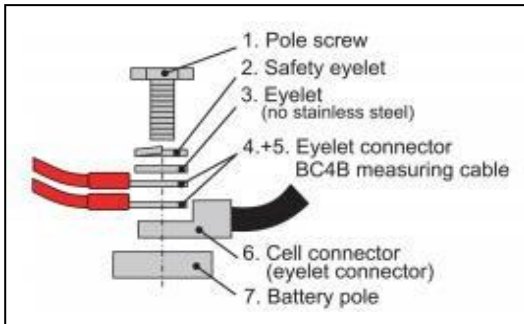

The BC4B measuring cable provides 4 connectors: two for the positive pole and two for the negative pole. When installing, pay attention to the color coding as well as the correct connection. Wrong wiring will trigger the measuring cable build-in fuse - the fuse cannot be repaired or replaced. To avoid damaging the battery as well as the measurement cable, use the torque ratings tested by the according manufacturer.

How to connect the BC4B test leads to four-pin 1.2V - 2V Batteries.

Some manufacturers use Batteries with four contact points. Coming with this design, two contact points are assigned to a positive or negative pole. Since the EQUALINK measuring cable provide 4 connectors, they must be fitted accordingly to the battery.

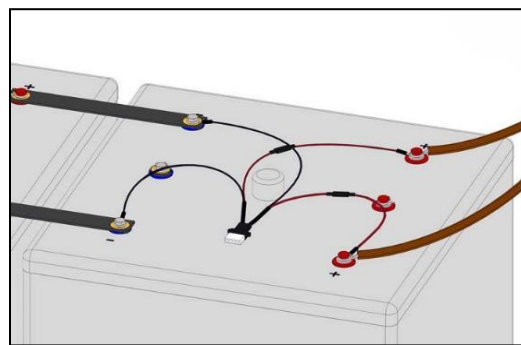
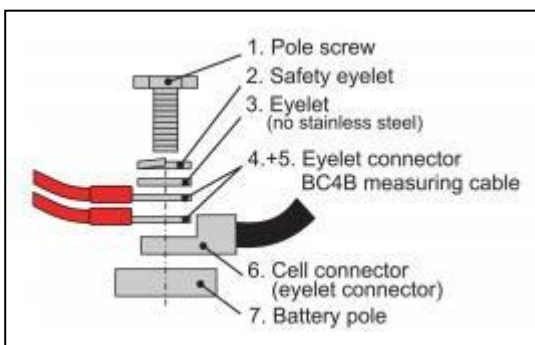

### Mounting the EQUALINK module at the battery

Please not the preconditions ....

- there is no dirt on the surface.
- The surface is free from fats, silicone or other coatings.
- The site is easily accessible for maintenance or subsequent service
- If possible, do not cover any valves or cooling fins
  - o In the case of sealed Batteries, velcro tape can also be attached directly on it if there is no other way. An AGM valves would in case of opening separate the velcro connection and the pressure escapes.
- For low maintenance Batteries and wet cells, keep at least 10 cm distance to the vent pipe

Before installing the EQUALINK modules, carefully read the installation and maintenance instructions for the corresponding battery.

### Wiring the EQUALINK module



The EQUALINK cables are coded and standardized, an erroneous connection is normally not possible. Connect the EQUALINK bus cables to the modules:



For larger cable lengths and installations, please take care for ...

- the maximum cable length including all modules must not exceed 50 m
- Do not install more than 50 modules per cable harness- If more than 50 Batteries are in use, a plitting box is mandatory to splitthe battery site into two different strangs.
- not exceeding the total number of 500 modules.
- installing the modules that the connection sockets are not live after connecting the cables.
- avoiding excess cable lengths

#### Note

keep an eye on logical cable sequences when connecting - BACS does not tell you how to connect all modules or in which order you address the modules. For technical reasons, a network short circuit is not possible by placing rings within an installation. Structured cabling and related documentation, however, facilitates system maintenance, especially when individual modules need to be replaced within the installation.

Furthermore, if using a splitting box and set up several strings, a structured hardware configuration is mandatory to set up the BACS configuration.

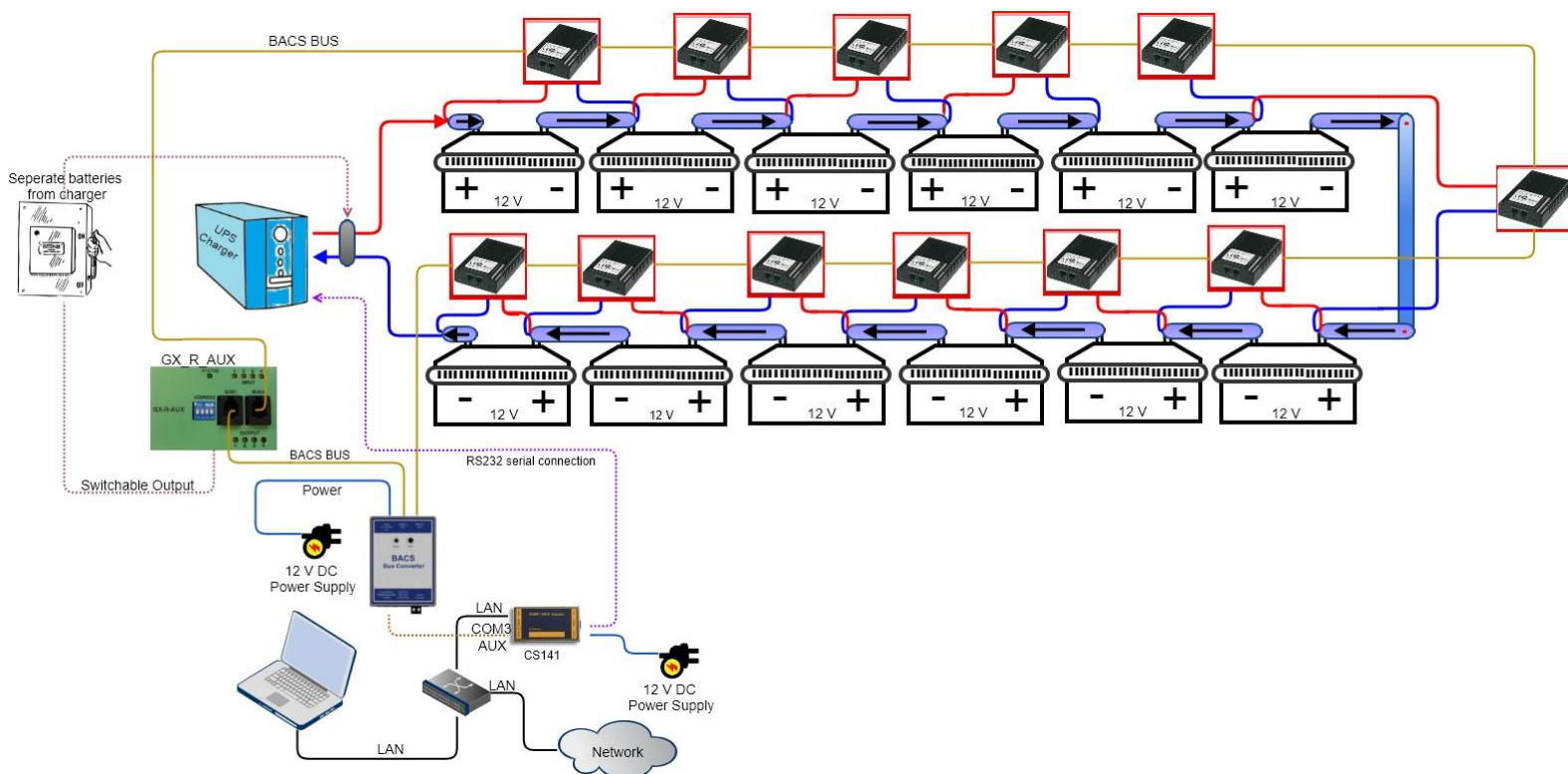

## Tutorial: Montage von EQUALINK BC Messkabeln mit Überwachung der Zellverbinder

*What is the function of the cell connector*

Depending on the type, there are plugged, crimped or screwed transition elements between the individual Batteries to connect Batteries in series. Due to their function, these connecting elements represent critical areas within the battery system:

- Due to the series connection, the cell connectors pass on the charge and discharge current to the next cell, whereby very large currents can arise depending on the size of the system.
- They are firmly connected to the battery poles and therefore also absorb thermal energy from passing current as well as the heat generated by the redox reactions within the battery. Both the poles of a battery and the screw connections and connecting elements between Batteries are repeatedly exposed to mechanical and thermal loads. In this way, the thermal energy can also be transferred directly from one battery to the neighboring Batteries. The connecting elements here are normally standardized components that can be neglected accordingly.

*Why you should monitor the connectors between Batteries?*

If failures occur during installation or maintenance, such as torque values not adhered to (incorrectly tightened, over-tightened, etc.) or the usage of incorrectly dimensioned and damaged connecting elements, it can lead to system-critical failures and even a battery fire within a few minutes. If you now only monitor the battery itself in addition to the general charging current, a problem with the connecting elements between the Batteries will not or can only be determined to a limited extent, e.g. due to unusual temperature developments or deviating charging currents, etc.

While the temperature developments can still be localized, unclear currents are difficult to localize - it is difficult to narrow down exactly which element causes this loss.

It may make sense in the highly critical system area to include the connection modules in the battery monitoring.

How to include the connectors between the Batteries

Classically, the EQUALINK-Module are installed as followed:

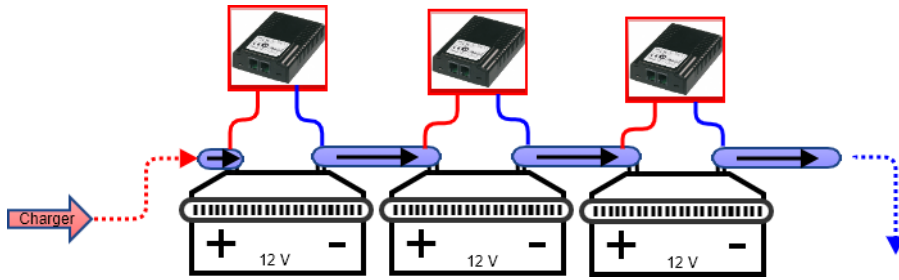

Jede Batterie wird hierbei von einem EQUALINK-Modul betreut und entsprechend geregelt. Grundsätzlich reicht dieser Schutz aus, da ein Problem batteriebezogen auftritt. Dabei werden Neben dem Widerstand auch Innenwiderstand und Temperatur der Batterie gemessen. Sollte es zu einem Problem kommen, wird das entsprechende EQUALINK-Modul diese aufspüren und der Webmanager entsprechend messen.

Wenn die Verbindungselemente in die Messung einbezogen werden sollen, muss der Messpunkt für die EQUALINK Messkabelentsprechend angepasst werden:

Technisch betrachtet wird immer vom Pluspol einer Batterie zu dessen Minuspol gemessen. In der Reihenschaltung bedeutet dies, dass der Pluspol der Folgebatterie vom Potentialgefälle her auch dem Minuspol der vorigen Batterie entsprechen muss:

At a serial connectino of Batteries, the netative pole of a battery will be connected with the positive pole of the next battery.

Depending on the measuring point, the connector is included or excluded.

At a serial connectino of Batteries, the positive pole of a battery will be connected with the negative pole of the previous battery.

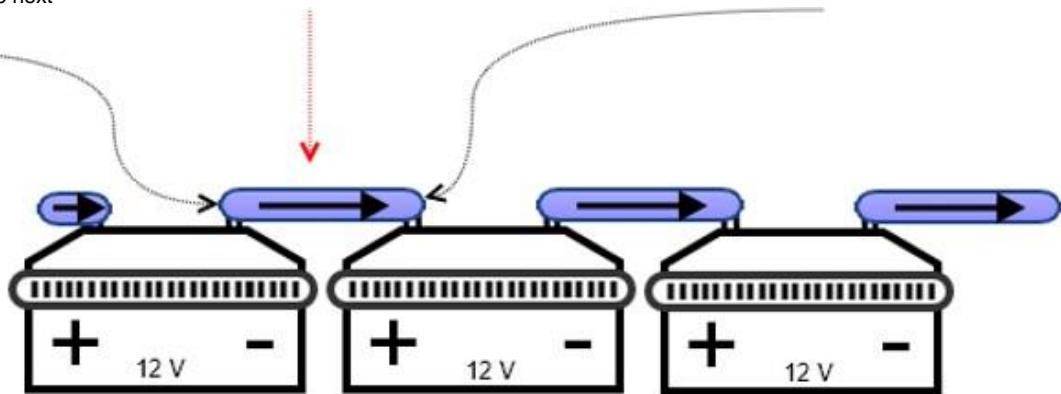

This results into the following structure:

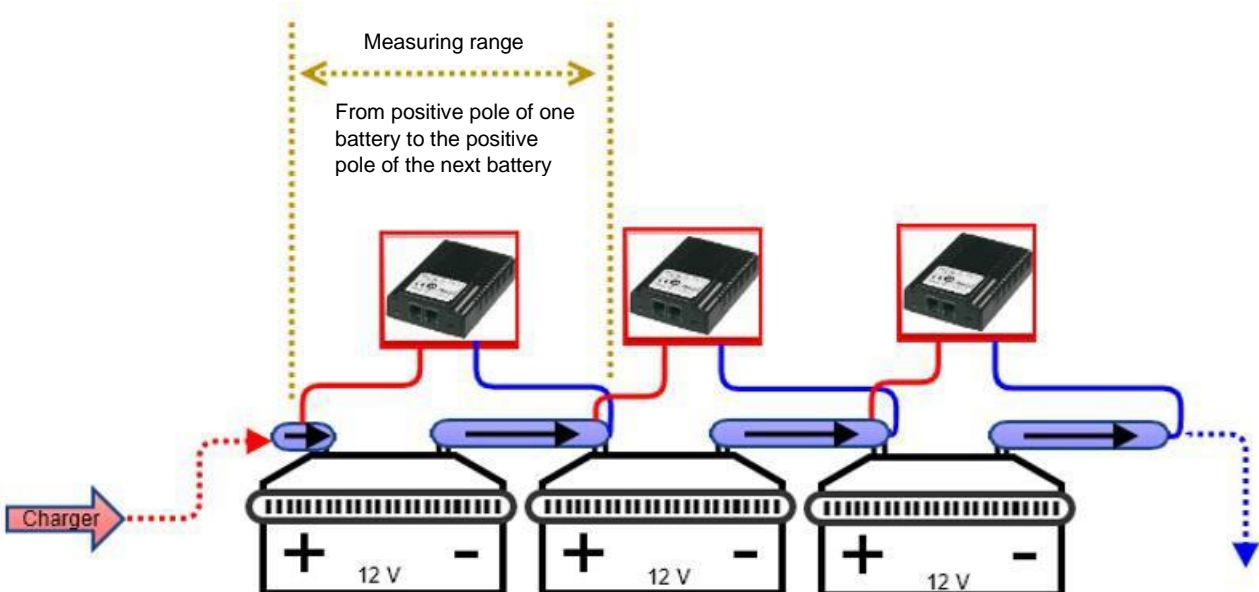

*Do values have to be adjusted in the web manager?*

No, the EQUALINK modules themselves always take care of one battery - the deviations that the connecting element generates because more material that has to be measured are normally less important. In theory, you could change the existing EQUALINK installation at anytime and integrate the cell connectors accordingly.

*What can be achieved with this measurement setup - an idealized example system failure analysis*

Basically, this measurement method ensures that both the battery and the transition to the next battery are checked.

In this way, if a current sensor in the string reports a deviating current flow, it is easy to spot the battery with the problem is to be sought for:

With the internal resistance measurement of the Batteries, the connector is included: If the measured values reach questionable values, the corresponding module will work independently and make itself noticeable.

Otherwise, the problem can be identified by evaluating the data situation:

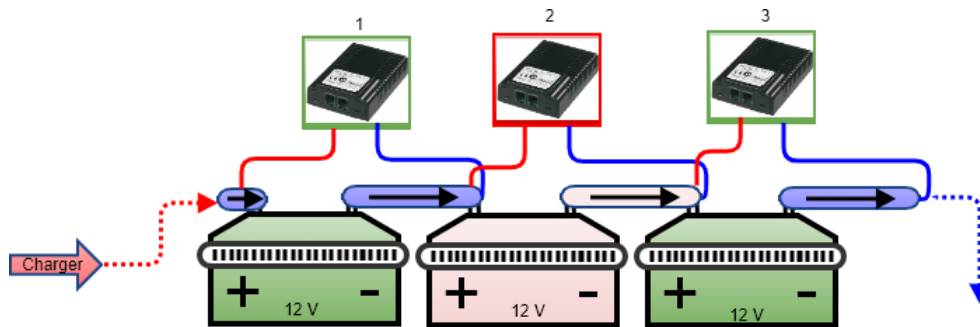

The entire battery string provides strange fluctuations in the flow of electricity. In this example you can see an unusual internal resistance in EQUALINK module 2. The problem can be narrowed down as followed:

EQUALINK-Modul 1 shows no problems:

As a result, all screws on battery 1 must be properly tightened. The same applies to the input screw of battery 2, since the connector is measured via the EQUALINK module 1. If this connector were loose, you would have to see it in the measurement results of EQUALINK Module 1.

The same applies to EQUALINK-Modul 3:

The measurement extends from the positive pole to the positive pole of the subsequent battery (i.e. battery 4) - so the input screw of the connector coming from battery 2 must also be OK.

EQUALINK module 2 reports a strange internal resistance

Likewise, there can be no problem with the incoming screw terminal from battery 3, since EQUALINK module 3 monitors the incoming terminal from battery 3 and the incoming terminal from battery 4.

There are only a few questions left:

- Is the outgoing terminal of battery 2 was not attached properly?
- Is there a problem with the connector between battery 2 and battery 3 itself?
- Is the battery 2 itself has a defect?

If you want to be sure, you would now look at the temperature data of the 3 Batteries and look for abnormalities:

If battery 2 heats up quickly during discharge / charge cycles and is then transferred to battery 3, the fault is clearly with battery No. 2. However, if Batteries 2 and 3 heat up evenly above average to the rest, the fault with the cell connector is possible - it heats up very quickly and transfers the heat to the Batteries via the battery poles.

**Note:**

Since the connectors are included into BACS, it is possible to general down times of the UPS and search for a problem - you know what you are looking for. If several batteries are affected, this method allows a strategic overview to plan the maintenance work.

## Maintenance: Replacing a single a EQUALINK module

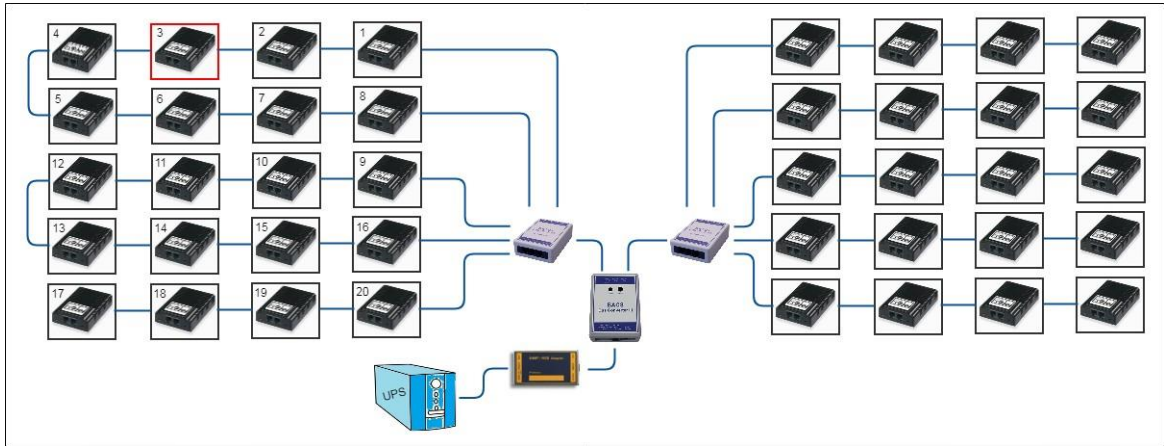

### Part 1 – Replace a single module

This example describes a problem with EQUALINK module 3. Since the module 3 comes with a ring wiring, the modules 2 and 4 are still available and work properly. By comparison, if module 19 would fail, modules 17 and 18 would have been equally affected - the connection design is not a ring structure.

However, in case of a failure, the EQUALINK webmanager will report a problem at module 3.

How to proceed: First open the battery separator to avoid an electric shock, safe your work place and take enough time to obey the security rules for working on live parts.

1. Identify the harmed EQUALINK module

Locate the EQUALINK module with the associated battery and remove the EQUALINK data cable. It is important in this context that the exact ID of the EQUALINK module is known so that you do not accidentally replace the wrong module.

2. Remove the EQUALINK data and measurement cables

Remove the EQUALINK data cable as well as the measurement cable. Please note that the EQUALINK measuring cables installed on the battery side do not need to be removed - the changed EQUALINK module will be re-connected.

3. Install the spare EQUALINK module

First connect the EQUALINK module to the measuring cables and proceed to connect the EQUALINK data cables. After the module has been initialized, press the button on the EQUALINK module for about 10-15 seconds:

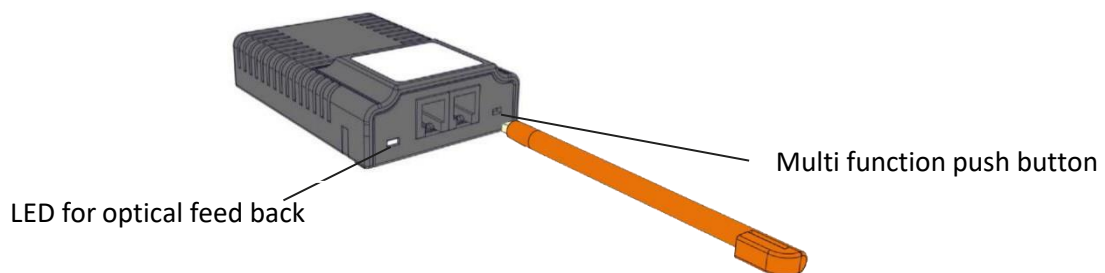

This forces the replaced module into a reset and it reverts to ID 0. This procedure will have effect on this specific spare module and not the entire EQUALINK installation. After reset, the module should now slowly flash red as an indication that it is now running on ID 0.

4. Open the build-in EQUALINK programmer and configure the spare module

The module is currently with ID 0 in factory default state. Due to the fact there is only one module that provides ID 0, it is possible to set manually ID 0 to the ID of the broken EQUALINK module. After leaving the EQUALINK programmer mode, EQUALINK will initiate and the new module is active.

Part 2: Replacing a temperature module

Some module revisions have a temperature sensor that can possibly be replaced on site. These instructions show how you can replace



such a sensor.

1. *Preparation*

First disconnect the EQUALINK measuring cable from the module and disconnect the EQUALINK bus cables. Take the module to an antistatic work place to avoid possible damage from electrostatic charge.

2. *Open the module*

The module is designed for easy opening without additional tools:

3.

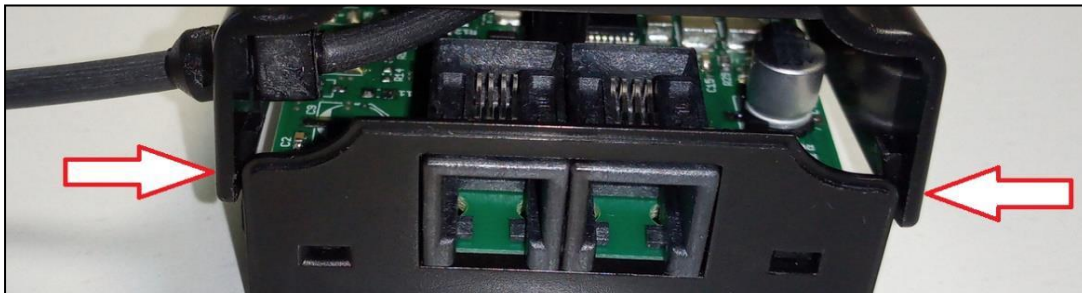

On the front of the module, there are two retaining clips on the left and right, which can be easily released by carefully bending the cover. By doing so, the cover shell can be removed from the module.

4. *Replacing the temperature sensor*

Depending on the type of module, the installation place of the temperature sensor differs:

*The internal sensor*

The internal sensor is attached at the bottom of the of the housing:

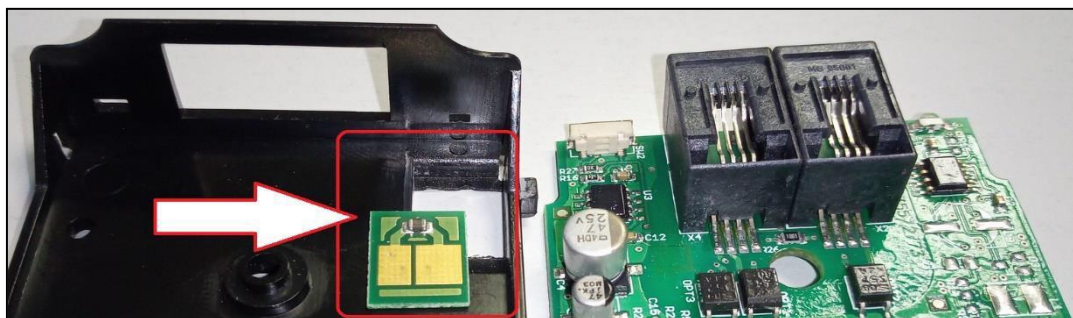

Remove the module board to get access to the sensor. You can then remove the sensor from the shell with a slight pressure from below. Insert the new sensor. Pay attention to the correct installation direction - in this special case the sensor board can be assembled the wrong. If assembled correctly, the two clamps on the back of the module board will press on the contact plates on the sensor board.

*The external sensor*

You do not need to remove the module board. Just remove the connector of the sensor cable.



The connector is coded so that it only fits in one direction on the module. When carrying out the work, make sure that the ESD guidelines are observed to prevent electrostatic discharge during assembly - these can damage electronic components.

5. *Re-assembling the module*



*Modules with the internal sensor*

Place the rear retaining bracket into the module housing and snap the front retaining clips into place with slight pressure.

*Modules with an external sensor*

First place the strain relief at the corresponding recess in the upper module shell:



Then reassemble the module accordingly. Ensure when putting the two shells together, the cable of the external sensor is behind the plastic web for the module screw to avoid damaging it when using a DIN rail:

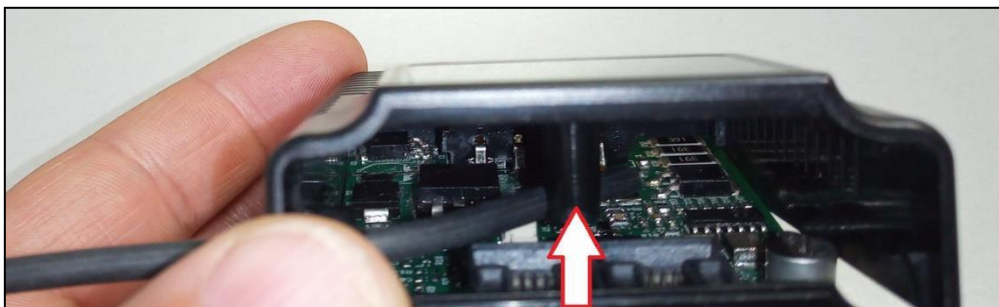



## Initial EQUALINK Installation: Configuration of EQUALINK

### General battery data



Open the general battery configuration dialog and enter required battery data:

Nominal Battery Voltage	<input type="text" value="12"/>	→ What is the battery voltage of used batteries?
Nominal Capacity per Battery	<input type="text" value="7"/> Ah	→ What capacity provide the batteries?
Number of Batteries	<input type="text" value="1"/>	→ How many batteries are installed?
Number of Battery Strings	<input type="text" value="1"/>	→ How many strings do you want to set up?

During installation and configuration process, you may choose between different procedures - Since each procedure comes with its specific advantages and disadvantages:

In this case, it is up to you to decide whether first configure the EQUALINK modules and then set the number of Batteries or first configure the number of Batteries and set up the ID of the EQUALINK modules during installation.



How to find general battery data:

Since these data are mandatory for EQUALINK module configuration, please refer the datasheets of the Batteries as well as the name plate attached to the Batteries:

In this configuration example, the voltage is 12V with a capacity of 7Ah

### Nominal Battery Voltage

Define the voltage each single battery provides. Please note that you may choose between different battery models as long as the voltage is identical:

it is not possible to combine different cell voltages!

### Capacity per Battery

Enter the capacity of the Batteries in ampere hours. Please note that manufacturers decide how to specify this value inside datasheets. If necessary, convert the values beforehand. This value defines the level of Equalization:

According to the AH value, the EQUALINK modules will be allowed to roll out a maximum Equalizing:

An AH value under 150AH will limit the provided Equalizing power to the size of such smaller Batteries, beyond 150AH EQUALINK will use its full Equalizing power which is available for this module type.

## Number of Batteries

Define the total number of Batteries within your EQUALINK installation.

As an example, if you use 40 Batteries inside your system, enter 40. Since each battery gets its own EQUALINK module, The EQUALINKwebmanager will search for a total of 40 EQUALINK modules, starting with ID 1. The ID 0 is not allowed during normal operation.

## Number of battery strings

Number of battery strings defines a logical assignment of the configured Batteries in combination with built-up Batteries. Among otherthings, the number of strings is defined by the physical wiring of the Batteries. As an example, 20 Batteries may be installed into one positive string and 20 into the according negative string. Such a middle point battery setup requires in EQUALINK a configuration as "2 strings" since the charger handles the positive and the negative string separately. Other installation types would be in this case of 10 Batteries in string 1, 10 Batteries in string 2, etc.

According to this context, it is important the physical wiring of the Batteries match the logical structure of the strings. The EQUALINK systemuses the sequential numbering of the EQUALINK modules during initialization and divides them by the number of battery strings..

If arbitrarily connecting the EQUALINK modules to the Batteries and activate EQUALINK, EQUALINK will logically initialize the EQUALINK modules into astring with IDs 1-10, followed by IDs 11-20, ...

Physically the EQUALINK modules may form up a shredded string that islogically correct. As a consequence, EQUALINK would receive wrong readings and possibly not even start: The strings will be displayed separately in the EQUALINK monitor and treated accordingly during regulation.

When assigning the EQUALINK modules, pay attention to the position or numbering of the Batteries in the battery compartment itself to match the logical assignment with the current installation: Ideally battery no. 1 also received the EQUALINK module with the number 1.

### Something more to take an eye on

For technical reasons, it is not possible to connect and manage an unlimited number of Batteries to a single string. From 50 Batteries onwards, we recommend to "split" the EQUALINK bus, ie to define two different cable strings per definition in order to keep the cable lengths as short as possible.

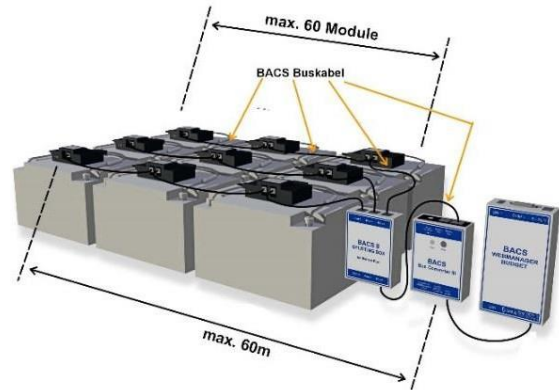

### Note

With String Names it is possible to enter a freeform label for the battery string. you enter a name for up to 16 battery strings before configuring the BACS modules. However, the number of strings will be define at Number of battery strings. that will be shown. Entering a name does not automatically increase the number of battery strings.

## Two Jars / Cells per module: The configuration NiCd based Batteries differs

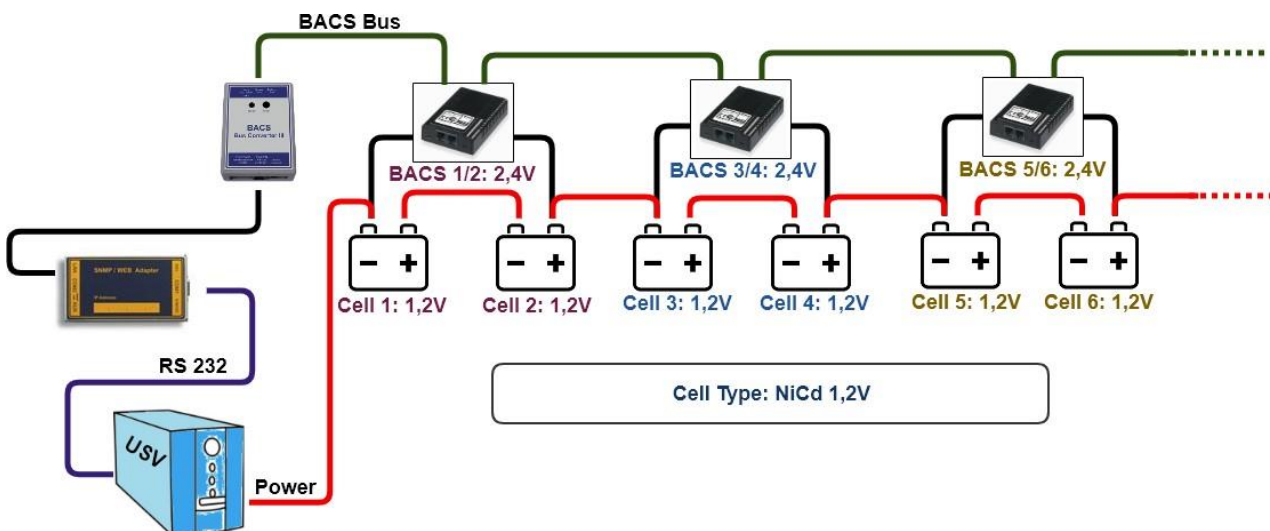

NiCd - based Batteries use a cell voltage of 1.2 V - therefore, with this type of battery, 2 Batteries will be managed by a single EQUALINKmodule.

### Configuration

To handle NiCd correctly, EQUALINK must be informed that in this case 2 Batteries are be combined and will be managed by one module. In order to avoid a configuration failure, this function can only be activated if the nominal battery voltage has been set to 2 volts.

At Devices>EQUALINK>Setup, the according configuration menu can be found:

Nominal Battery Voltage	2	→ Set the nominal battery voltage to 2 V
Nominal Capacity per Battery	7 Ah	→ Enter the capacity of the batteries
Number of Batteries	6	→ Enter the number of batteries in use*
Number of Battery Strings	1	→ Define the number of battery strings
Two Jars / Cells (NiCd) Per Module	<input checked="" type="checkbox"/>	→ <u>Enable Two Jars / Cells</u>

\*) Since you have combined two Batteries for measurement and management purposes, the number of Batteries is twice as high as the number of installed EQUALINK modules. That's why you need to enter the number of Batteries and not the number of EQUALINK modules.

### The EQUALINK Monitoring Screen:

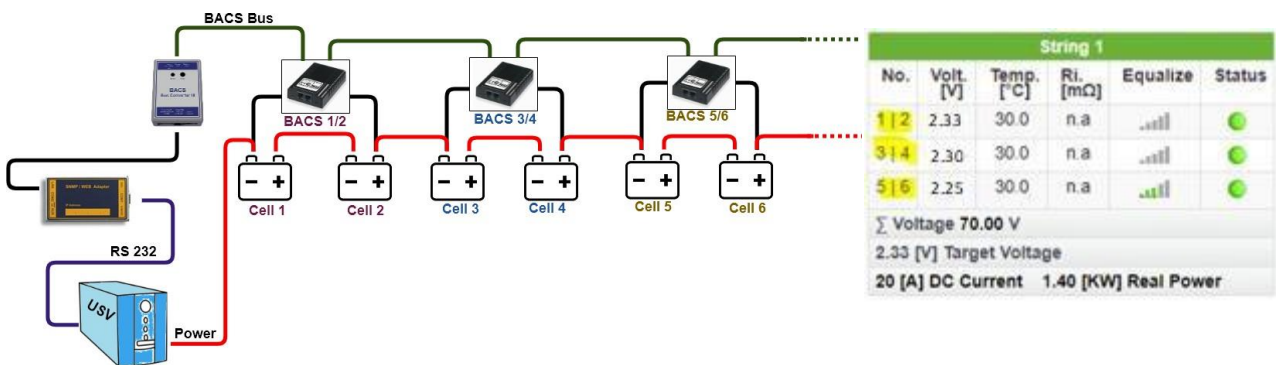

After initialization, EQUALINK will not list the number of modules in use, but the number of Batteries actually managed by the modules.

### Helpful information about the EQUALINK system

Information	
Battery Manufacturer	→ Manufacturer of the battery
Battery Type	→ Installed battery type
Battery Location	→ Where are the batteries installed?
Battery Installation Date	→ Installation date of the batteries
Contact Person	→ Responsible staff
Contact Person Phone	→ Direct phone contact data of staff

### Battery manufacturer and type

Enter the designation as free form text. If useful, add some information about its function or the intention of this battery system or in special cases chemistry used for this battery room. If an incident occurs and rapid interaction is mandatory, this information can increase the average response time. On the other hand, misleading or poorly documented terms can cost valuable time.

### Battery installation date

The battery installation date indicates the date of initial battery installation. Since a system can be upgraded with EQUALINK at any time, it is important to be familiar with the difference of a battery installation date and the installation date of EQUALINK.

You will usually find the battery installation date on the battery itself as "date of manufacture"

### Contact person and phone contact

In case of maintenance work or incidents, responsible staff can be contacted to shorten response time.

#### Note

If wanted, BACS can send general contact information to a custom mail address and contact responsible staff directly. However, your entry at contact phone cannot be used for automatic SMS notifications - An SMS modem or IP modem must be configured separately.

### EQUALINK module basic setting

Module	C20	→ Choose the module
Equalizing on	<input checked="" type="checkbox"/>	→ Enable / Disable BACS
Optimize Scan	<input type="checkbox"/>	→ Optimize Equalizing scan
Choose Discharge Detection Source	Automatic	→ What to use as discharge detection?

### Module

Different voltages on the Batteries require different EQUALINK modules - please ensure to select the EQUALINK module type fitting to your Batteries. Depending on the voltage selected for the Batteries, it will display modules fitting to the voltage. Currently the following modules and voltages are available:

Cell Voltage	Selectable module
2 V	C40 / C42
4 V	C41
6 V	C30
12 V	C20 / C21 / CSYM
16 V	C23
24 V	CSYM

Nominal Battery Voltage	2
Nominal Capacity per Battery	7 Ah
Module	C40 / C42
Equalizing on	<input checked="" type="checkbox"/>
Optimize Scan	<input type="checkbox"/>
Choose Discharge Detection Source	Automatic

Obey the correct settings. An unsuitable combination of UPS, modules and Batteries may lead into system failure and damage.

### Equalizing on

Equalizing is a protected voltage distribution control system inside a battery pack, the Batteries will differ from each other. As a consequence, they need individual regulation of charging voltage to reach the target charging voltage of the charge controller.

Since Equalizing intervenes in the charging circuit and actively regulates,

it may be necessary for new installations to operate the Batteries for some time without this regulation. This will allow Batteries to "form" up each other. During this time window, new Batteries will be operated without regulation, the voltage differences need to be tolerated. Please contact your battery manufacturer if their battery products need such a time window and how long it should take until Equalizing can take over in order to protect your Batteries.

The installation of the EQUALINK modules as well as fetching measuring data with the EQUALINK system is completely independent to equalizing - you can install and operate all EQUALINK modules without charging control and active regulation. Equalizing can be activated at any time. If activated, EQUALINK will take over the care of the Batteries.

### Optimize Scan

Normally, only a small amount of data is collected and stored during trickle charging. Since the parameters of the battery will not change very much during a trickle charge, only a small amount of data is collected and stored. This will change during discharging:

When discharging, considerable amounts of data are generated. Furthermore, EQUALINK increases the sampling rate in order to record the event as accurately as possible during an evaluation by additional freeware tool EQUALINK VIEWER. The scan optimization reduces the data points to the measurement of voltage values. By doing so, changes in a discharge cycle can be recorded much more accurately.

### Discharge Detection source

EQUALINK offers alternative options to differentiate between a charge and discharge cycle. By default, EQUALINK will automatically select the best source and, if necessary, query alternative sources:

- UPS

The UPS provides the fastest and most reliable detection rate due to the fact it will switch in case of a powerfail to battery mode. Depending on the design, the EQUALINK system can use the CS141 slot card, an RS232 interface or even the RFC1628 network interface in the network to obtain the information, among other useful information, about detecting a discharge.

- *Current sensors*

The direction of the magnetic field induced by current flow is a probable method to figure out if the Batteries are currently in state charge, trickle charge or discharging. Although the detection rate is slower than querying the UPS. Current sensors provide additional measurements of the quality of the discharge current. The current sensor selection would be the best detection source if a UPS state query is impossible.

- *EQUALINK sensors*

The EQUALINK sensors can also perform a discharge detection:

The modules measure the battery voltages - from the moment the voltage drops below the rated voltage, EQUALINK will assume a discharge is in progress. Since the Batteries take a while to fall from the trickle charge to the rated voltage and stay there for awhile before dropping below this value, it is a reliable but very slow option to figure out if a discharge is in progress.

Normally, this detection source is selected if neither UPS nor current sensors are available.

**Note**

A rechargeable battery needs some time to fall from trickle charge values to its rated voltage. This natural process can be misinterpreted as "discharge". For this reason, a battery monitoring or management system needs the ability to differ between this natural process and a battery discharge:

BACS can do this job and will increase the detection and logging rate only if a real discharge is confirmed.

To improve detection rate, additional current sensors are recommended- if BACS detects a voltage loss as well as current flow, the discharge status is confirmed.

**Offset values**

Offset Values	
Temperature Offset	<input type="text" value="0"/> °C
Impedance Offset	<input type="text" value="0"/> mΩ

→ Enter temperature differences  
→ Enter impedance differences

EQUALINK modules are calibrated on delivery and will give an exact value related to the calibration. However, the EQUALINK system can not know the general installation location and it may be possible that the calibrated measurement results differ from external reference measurements due to the installation site. Air pressure, humidity, ambient temperature and other environmental variables can distort the values collected by EQUALINK:

The calibrated values need to be corrected if necessary.

With the offset values, it is possible to enter correction values coinciding with measurements at the installation location.

**Impedance Measurement Interval**

Impedance Measurement Interval	
Start at	<input type="text" value="08:00"/>
Repeat every	<input type="text" value="12 hours"/>

→ First impedance measurement log entry  
→ Repeat and log in this time intervals

Due to the nature of their function, Batteries are subjected by a partial hidden aging process - a gradual process that cannot normally be observed unless continuous measurement data on the internal resistance are available by chance. For reliable trend detection, it is therefore important to regularly measure the internal resistance of the Batteries:

These data logs can be used to identify the real internal age of a battery and thus the probability of a total failure.

Since it is possible to compare all EQUALINK-supported Batteries directly with one another using the professional EQUALINK Viewer software, it is possible to identify an unusual increase in impedance and take appropriate countermeasures.

As a default, EQUALINK will automatically take the first measurement at 8 a.m. after initialization or a restart and then repeat every 12 hours. However, you can adapt the start time and repetition intervals to suit your service plan.

## Current Sensor

BACS CS Current Sensor Connected	<input checked="" type="checkbox"/>	→ Enable / Disable BACS current sensor
Only One Current Sensor For All Strings	<input type="checkbox"/>	→ Number of installed current sensors
Reverse Current Direction	<input type="checkbox"/>	→ Direction of installation
Ampere Multiplier	<input type="text" value="1"/>	→ Multiplier

Each EQUALINK module already provides its own charge / discharge detection.

The detection by the EQUALINK modules arises from the need for Batteries to generally have a slight discharge curve and lose their chargeover time.

However, this charge / discharge detection is realized by voltage measurements of the cell. If the voltage drops below a rated voltage, EQUALINK assumes a discharge is in progress. What the EQUALINK module does not measure is the current flowing through the individual strings during a battery discharge cycle.

In addition to the charge / discharge detection, the current sensor can also be used to check whether the currents are divided equally between the parallel battery strings as well as the average quality and stability of the current.

### Installing the current sensor

If you want to use a EQUALINK Current Sensor, enable the EQUALINK CS Current Sensor Connected:

By default, the EQUALINK Web Manager searches for one current sensor per battery string - the number of EQUALINK strings will reflect the number of sensors that need to be found. At EQUALINK monitor, the result will be displayed below the according string.

18	13.58	30.2	18.85		
19	13.58	29.9	18.63		
20	13.58	30.0	18.84		
Σ Spannung 271.65 V					
13.58 [V] Target Voltage					
0 [A] Strom 0.00 [KW] Reale Leistung					

→ Current sensor

### **Premium feature: Only One Current Sensor for All Strings**

Usually each battery string gets its own current sensor to get information about real current flow on all strings. In some cases it is desirable by customers to use only one current sensor for a general charge / discharge detection. By doing so, EQUALINK needs to know that only one current sensor is installed:

Enable "Only One Current Sensor for All Strings" and press apply to restart EQUALINK.

After restarting EQUALINK, only one sensor will be automatically displayed. If the current sensor is installed on a string, the ampere multiplier value will get approximate overall current value.

### **Premium feature: Ampere Multiplier – how it works**

The ampere multiplier multiplies the measured current by a theoretical factor in order to draw conclusions about the entire system. The multiplier value to be entered depends on two factors:

1. There are several strings in the EQUALINK system - the number of strings determines the multiplier.
2. For various reasons only one current sensor is available

The multiplier can be used this way:

Main string:                      The current sensor measures main current                      value = 1

Single string:                      The current sensor measures the partial current of the string                      value = Number of strings

Since the measurements are not very exact in the end, this solution serves only the more accurate charge / discharge detection. It is not designed to determine more information than an exact charge/discharge detection as well as basic information about estimated current flow.

### **Note**

You will get the *best* results with a combination of current sensors inside each individual EQUALINK string as well as using the sensors coming with EQUALINK modules. By doing so, more data can be collected and analyzed:

- General voltage
- Internal resistance of the Batteries
- temperature of the Batteries
- quality and uniformity of the discharge current itself

However, EQUALINK offers you different graduated possibilities for discharge detections:

1. UPS status

The UPS knows the current charge or discharge status and will provide this information for the EQUALINK Webmanager. To choose this option, the EQUALINK Web Manager must be connected to the UPS. Depending on the EQUALINK design, you can choose between a single device or a modular solution. Even the combination CS141 slot card with EQUALINK BUS Converter can be used.

In other cases the connection is possible via the RS232 interface. If you use a UPS with SNMP access, it is also possible to configure an access via the RFC1628 interface and query the data directly via LAN. Current sensors provide additional current quality detection

2. If no communication to the UPS is possible, you can get accurate information via the current sensors and the EQUALINK modules.

- a. Charge-/Discharge detection
- b. Accurate readings on consistent charge and discharge cycles as well as quality and fluctuations of the current.

In this setup, the EQUALINK modules provide voltage values across the Batteries and the current sensors provide values about the current that actually flows per string.

3. If, for logistical reasons, you can only use one current sensor, it will in principle provide an exact charging and discharging detection source. But with one current sensor, it is just possible to provide a theoretical overview of the quality of the current that will flow during charge- / discharge processes.

Obey that the current sensors can be used either on the main line before splitting into single strings or inside a single string after splitting.

a. The main string

At the main string, the total current is measured. You will recognize a very accurate charge / discharge detection as well as information about internal fluctuation in the current flow, but you will not be able to get information about the strings that may trigger current flow problems.

b. At the single string

Like a main string installation type, you will find a very accurate charge/discharge detection. The difference is, that the single string installation will measure the real current at this point the current sensor is installed to. You can use the multiplier to approximate the value to reality, but it remains as some kind of rough estimate. What you can see accurate:

If the value for current drops, the problem has to be found in the string where the sensor is installed to. On the other hand, if the value increases dramatically, there is a problem in one of the other strings. Technically, a more exact limitation feasible in this constellation is not possible and the accuracy depends on the number of strings you have installed - With two strings, it is easy to figure out which string causes trouble. With three strings, two strings you have possible candidates...

4. You can also completely dispense the connection of a UPS as well as the use of current sensor. The charge / discharge detection can be fully mapped by the EQUALINK modules. The modules measure the internal resistance and the voltage of the Batteries they are installed on. The modules can measure if a charge cycle or discharge cycle is in progress. But it will need some time. This possibility, however, ignores the current that will flow during charging and discharging.

### ***Reverse Current Direction***

The current sensor measures the induced magnetic field coming with directed electron migration through a conductor. Due to the fact the current sensor can measure bi-directional, the installation direction is crucial:

The magnetic field of this directed electron motion provides information about the direction of electron migration.

With this function, the real magnetic field recognition can be inverted - thus will place charge and discharge recognition into a correct context. If the current sensor has been installed incorrectly, this function can be used to reverse the current direction and the sensor can remain in this installation direction.

### Thresholds for current sensor discharge detection

Thresholds	
Discharge	<input type="text" value="-1"/> A
Charge	<input type="text" value="1"/> A

The direction of current flow indicates whether the Batteries are charging or discharging. In principle, you need to differ between three charging or discharging states:

1. Discharging

The Batteries discharge while granting emergency power.

2. Charging

If Batteries drop below a certain voltage level, they must be charged. This battery state can be reached via a natural discharge process over time or in case of emergency power usage. The charging process is always initiated and terminated by the UPS / Charger. By "Equalizing", EQUALINK distributes the existing charging current and voltages - Each battery charge is considered individually to ensure the optimal charging.

3. Trickle charging

Batteries tend to self-discharge over time. This process can not be prevented, but slowed down by proper storage. The trickle charge hereby serves to maintain the current state of charge. Normally, a trickle charging will not be displayed.

Depending on the charging behavior of a UPS, certain currents always flow within a system. Due to this fact, it cannot generally be assumed that a current flow is automatically a charge / discharge cycle. Since only two of the possible states are important for the current sensor to detect a charge or discharge cycle, it is necessary to define a fixed point at the current intensity for a charge/discharge cycle.

With the "Thresholds", the values can be adapted to the environment that a clear charge or discharge cycle can be assumed.

The negative sign defines the discharge cycle and the positive sign the charge cycle.

### How to configure the EQUALINK modules

Addressing EQUALINK modules: The EQUALINK programmer

The EQUALINK modules can be configured by using the WINDOWS program EQUALINK PROGRAMMER or via the web interface in the CS141 /EQUALINK WEBMANAGER.

To use the EQUALINK programmer in the web interface, navigate to the following menu:

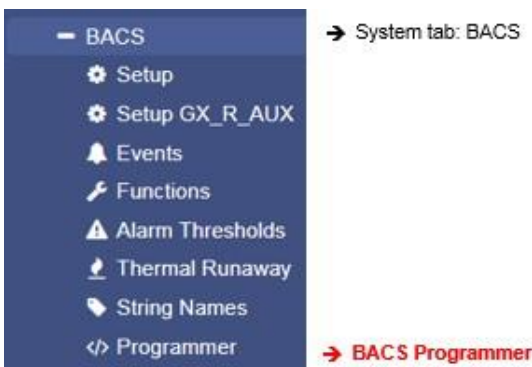

To install, configure, or remove new EQUALINK modules, the EQUALINK system must be put into standby for this time window. First set the Programmer Input Capability to "On":

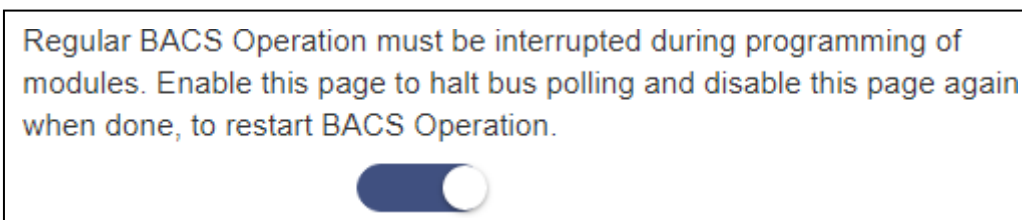



Please note that the button generally describes the state that is currently available. While the Programmer is active, EQUALINK pauses –the current system state can be seen at the top status bar off he Webmanager:



Two conditions will disable the EQUALINK programmer and enable regular EQUALINK functions:

1. Cold start or reboot

During a cold start, the device is de-energized briefly and then reboots. A reboot will be advised by an administrator via tools or directly via the web browser reboot command. In both cases, the default startup setting will start without the EQUALINK programmer set to on.

2. Enable or disable manually

The EQUALINK Programmer does not have an automatic activation function - it is started manually by an authorized user and must be terminated accordingly. If you log off as an administrator from the system, the EQUALINK Programmer remains active, even if you subsequently log in as an engineer.

#### Note

Always remember to disable the BACS programs after using. An internal watchdog will permanently look if there is activity on the BACS bus. After 15 minutes without some kind of activity, this watchdog will assume something is wrong and trigger a reboot.

Once you enable the feature, the BACS Web Manager will adjust its BACS status accordingly:

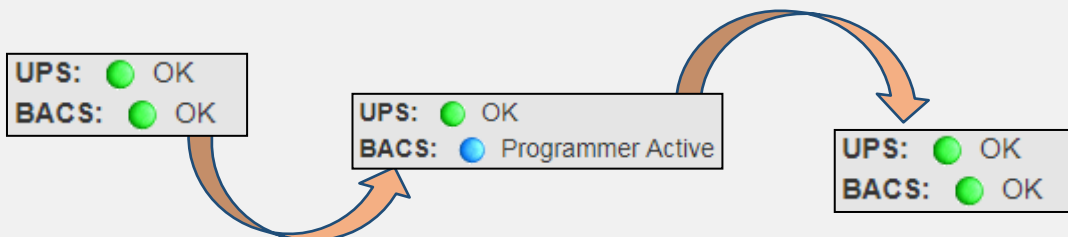

Normal operation and any communication on the BACS bus is paused by user for maintenance work. After finishing maintenance work, the BACS programmer will be disabled and normal operation starts. The BACS bus watchdog is not part of the CS141 - it is placed on the BACS Bus Converter and will interpret the entire communication between CS141 and the BACS modules - and restart the CS141 in case of a communication failure.

#### Addressing modules

##### Change the ID

During initial commissioning, the EQUALINK modules must receive a unique ID in order to be able to register with the EQUALINK Web Manager. In general, these addresses are static, but each EQUALINK module can be reset to factory default or programmed to any other ID.

Because reprogramming is possible, setting up an ID follows specific installation rules:

1. Each ID is unique and it is not allowed to set up one ID twice.

Duplicate registrations will produce errors when initializing EQUALINK because the modules can not be uniquely assigned to a battery.

2. Only sequentially numbered IDs are allowed inside the EQUALINK network.

The IDs are assigned to a specific battery a EQUALINK module is connected to. If 25 EQUALINK modules are expected, 25 Batteries are mandatory. You can not "turn on" module ID 26 with a new battery and "turn off" the battery with the EQUALINK module ID 17. You need to reassign the module-ID 17 to the new battery.

3. The highest ID number defines the number of Batteries you want to install.

EQUALINK will not scan for 25 Batteries with a connected EQUALINK modules, it will exclusively look for 25 Batteries with the EQUALINK modules ID's 1-25.

### Define an address range

Please remark, resetting modules may be necessary as of an initial installation - reusing modules for another EQUALINK installation is possible. In that case, the existing modules may still have arbitrary ID's from older installations. On initialisation, all modules need the ID 0.

First define the module ID range you want to reset. You are free to choose a complete range from 0 - 600 or - if wanted - limit the range: 250 - 450.

Check "Reset" and press the Start button to begin. The EQUALINK Webmanager will reset all modules and set them to 0. The modules will visually display this process by slowly flashing red.



part  
are  
to ID

### Note

In some cases, the modules may not have been reset by the BACS Web Manager, as an example, if a cable is damaged or individual modules are not properly accessed due to external interferences. You can manually reset these modules by holding down the button on the module itself for about 20 seconds.

### Set up all modules



When configuring the EQUALINK modules, please note that one EQUALINK module must have ID 1, otherwise the entire EQUALINK communication will not start after configuration. At Start, enter the first ID number you want to assign. With End, enter the last ID number you want to assign. Pressing Start will start the configuration process:

You will notice that all modules will begin to flash fast. The fast red blink indicates that the modules are in addressing mode and ready to confirm the ID number.

Start addressing by pressing the programmer button at the EQUALINK module. The module LED will change the color and blinking frequency into a slowly blinking green state. With each module button press, the EQUALINK Webmanager will count up until all numbers are set and the Webmanager shows the message: "succeeded"



Assigning address ID's can be stopped, if...

1. The number of ID's previously entered are confirmed
2. you press the Stop button.

The EQUALINK module programmer button



You assign the IDs by pressing the button on the EQUALINK modules. The module will acknowledge receipt of the ID by flashing from fast red into a slowly green. At the same time, the process bar in the web interface of the EQUALINK Web Manager will count up one ID. Please ensure not pressing the LED - this is not the button! You will find the button on the other side of the EQUALINK bus data cable connectors.

### Audible confirmation



On request, an acoustic confirmation can be set when assigning the EQUALINK Module ID. By doing so, the EQUALINK webmanager will generate an additional audio signal from every button operation..

### Define different address ranges

In larger installations with a huge number of modules, addressing modules is still mandatory. To increase clarity, it may be recommended to assign ID's to the EQUALINK modules step by step. For this reason, you can address different address areas one after the other.

Just divide the EQUALINK modules into individual address ranges:

Addressing sequence 1:	Address range 1-50,	Start-ID: 1 / Final ID 50
Addressing sequence 2:	Address range 51 – 100,	Start-ID: 51 / Final ID 100
Adressierungsdurchgang 3:	Address range 101 – 150,	Start-ID 101 / Final ID 150

Use the module addressing dialog Start and End to define a unique address range.

## Note

The individual BACS modules can be combined in so-called strings - the modules are logically divided into individual groups and displayed and measured accordingly. This logical assignment works on this principle:

Number of registered modules divided by number of strings gives the number of modules per string.

When setting up the modules, make sure that the logical assignment matches the physical structure:

The order of the modules within a string are less important for the function of BACS, but if the modules' position differs physically and logically, measurement and control errors will occur. Due to a wrong construction, the strings can be randomly thrown together and lead into problems with battery string breakers, current sensors, etc.

## Changing a single ID of a EQUALINK module

The "Single" function allows you to set and change individual module IDs of EQUALINK modules.

This function provides 3 different options:

- Switch an ID to another
- Switch an ID to 0
- Switch an ID from ID 0 to a target ID

The procedure is identical to all three options:

Under Old, enter the current ID that you want to change. Under New, enter the target ID to which you want to set the EQUALINK module. Unlike standard addressing, this mode requires no action on site at the EQUALINK module.

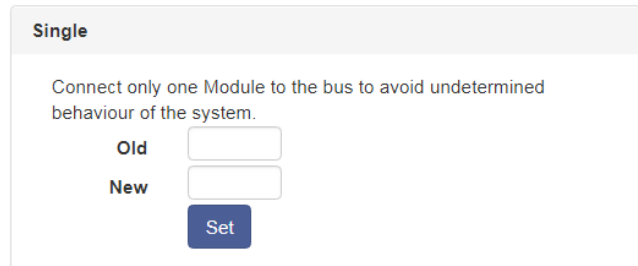

## Resetting module ID's

If necessary, the EQUALINK modules can be returned individually or completely to the delivery state. Depending on the procedure, only the ID will be changed or by pressing the modules button for 20 seconds, the modules will perform a hardware reset and fall back to the default ID 0.

*Resetting all modules or an address range to factory default*

This action will reset all specified ID's directly to factory default 0 as soon as you press Start. The modules will visually confirm the reset with flashing slowly red.

*Setting one single ID back to 0*

Resetting a single module can be done by two different methods:

1. Use the EQUALINK programmer

You can specifically reset a EQUALINK module to 0 in this way. As a consequence, the EQUALINK module will slowly flash red. This is useful if you want to swap a module, but you want it to be reset to the factory default state for later use within other installation.

By doing so, it is ensured that the ID is no longer in use before you remove the module..

2. Press the EQUALINK module button for about 20 seconds

With this option, the EQUALINK module will be forced to reset on the hardware side. Accordingly, all information contained in the module is deleted.

## Finding modules

Large EQUALINK installations can be very confusing for new guys.

In order to locate a specific EQUALINK module within all the strings, the programmer offers a fast and convenient solution:

Under Query you can optically flash individual modules with a red flashing. This will help you to find the according battery you wish to maintenance.

Simply enter the ID of the module you are looking for and click on "Show" - the module will start blinking slowly red/green.

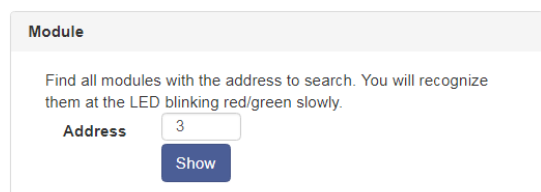

The module you are looking for will blink accordingly. You can choose between these two options

1. Go to the EQUALINK module and press the button.

Pressing the confirmation button on the module itself will release the search function and the module falls back to normal operation mode.

2. At EQUALINK Webmanager, press OK to confirm search is over.

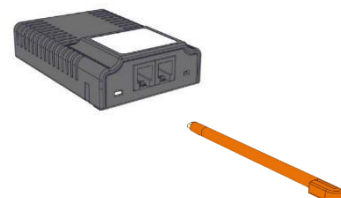

The module will be triggered by the EQUALINK webmanager to fall back to normal operation.

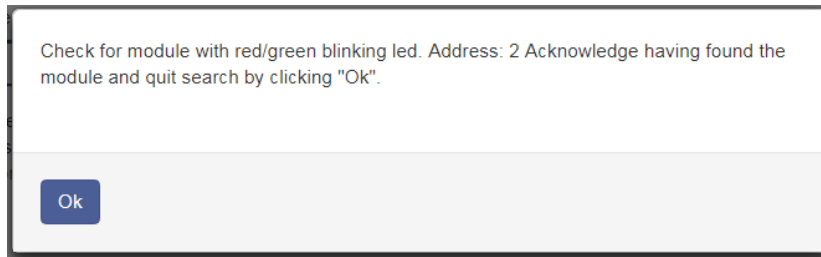

### **EQUALINK programmer Single mode**

The single mode is an option to program one single EQUALINK module or change module ID's inside an existing EQUALINK installation.

Please note for this function it is mandatory to know the exact ID of the according module you wish to program.

If you are unsure about the current ID, please reset the module to factory default ID 0. If you know the module's ID, you may skip resetting the module and use the current ID.

At „Old“, enter the current module ID. With „New“, the new module ID can be entered. Set will start the programming procedure. By doing so, it is not required to push the confirmation button at the EQUALINK module.

The EQUALINK module will confirm the setting by flashing slowly green.

#### *Using single mode inside a EQUALINK installation*

This function can be used to change module ID's inside an existing EQUALINK installation – this will allow to resort EQUALINK-Modules according to the physical wiring. The according module can be logically set to a string it is physically installed. Please note: You can program two modules with the same address. As a consequence, EQUALINK will not start because of an address conflict. If you set up two modules with the same address, you need to separate the ID's with a hard reset of one of these modules or by disconnecting one module. Otherwise these modules will receive and confirm the new ID simultaneously.

#### **Checking ID programming:**

If unsure, it is mandatory to check the ID's of the modules. With this tool you can check ...

- If the module responds to the intended ID
- If there are two modules with the same ID inside a EQUALINK installation.

#### *Search a EQUALINK module*

Under Module, enter the ID you want to find and press show:  
All modules will start blinking green, with one exception:  
The module with the entered ID will blink red/green.  
The blinking will stop by pressing the confirmation button of the module or at the EQUALINK programmer pop up confirmation dialog.

If you set up an ID twice, both modules will start blinking this way.  
If EQUALINK cannot find the module, it will display an according message.

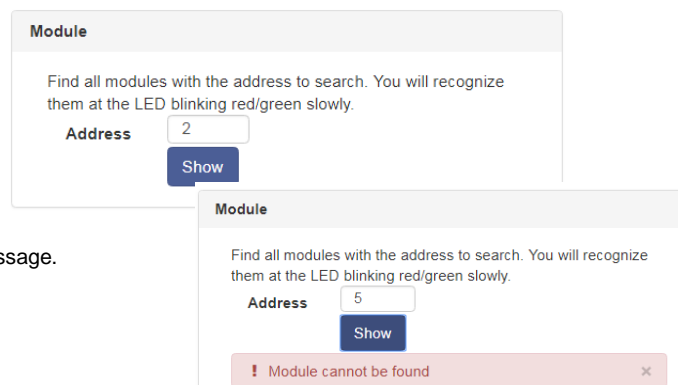
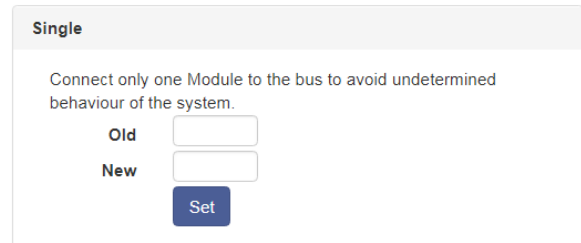

## EQUALINK Error: HW Revision / Calibration error

Once all modules are set up correctly and the EQUALINK programmer mode is disabled, the EQUALINK system boots and initializes the modules according to their configuration.

The result can be observed within the EQUALINK Monitor Screen:

After validating the entire configuration, all modules will jump to "green" - The system will be ready for use.

In some rare cases, however, this system message occurs:



The screenshot shows the BACS monitor interface. At the top, there is a blue button labeled "BACS". Below it, there are two status indicators: a green circle for "Status: Charging" and a blue circle for "Error HW Revision/Calibration mismatch". A note below these indicators states: "Please note that logfile timestamps require a timeserver." The main part of the screen displays two tables for "String 1" and "String 2".

String 1						String 2					
No.	Volt. [V]	Temp. [°C]	Ri. [mΩ]	Equalize	Status	No.	Volt. [V]	Temp. [°C]	Ri. [mΩ]	Equalize	Status
1	13.79	23.5	n.a.	...	●	3	13.79	21.0	n.a.	...	●
2	13.78	23.5	n.a.	...	●	4	13.84	25.1	n.a.	...	●
Σ Voltage 27.57 V						Σ Voltage 27.63 V					
13.79 [V] Target Voltage						13.81 [V] Target Voltage					

### HW Revision Mismatch

On initialization, the EQUALINK Webmanager assumes that the hardware revision for the module coming with ID 1 (The first module) is the reference for all subsequent modules. The Webmanager compares the hardware revisions with the revision number found at ID 1. If one of the following modules show different hardware revision, the module is marked accordingly:

EQUALINK modules from different installations can be combined as required. After adjusting the ID of the according module, the module can be inserted e.g. as a spare part. Different hardware revisions are not allowed - they cannot be combined with each other. If a module does not fit the EQUALINK system, it must be replaced by a corresponding module with a hardware revision that fits to it. In case of maintenance works inside larger EQUALINK systems containing several EQUALINK Web Managers, keep an eye on possible compatibility issues between the individual EQUALINK modules

#### **Note**

If ALL modules show this issue on initialization but not the first module, take a look at the module with the hardware ID 1:

It is probably affected and the following modules use the correct hardware revision.

In this case, exchange the ID 1 with a different ID via the BACS Programmer and repeat the boot process. Normally, all modules should now have the status green and this one module should be marked accordingly.

If you have just been supplied with a single EQUALINK system, please contact your local dealer: It is possible that this shipment contains a wrong EQUALINK module.

### HW Calibration Mismatch

The second test validates if the modules are calibrated:

First of all: you cannot re-calibrate them manually. The calibration is performed during production at the factory. Because the EQUALINK Webmanager needs exact values for its reliability, it checks if this calibration has been performed during the initializing phase. If a module does not pass this test, it is not suitable for operation:

Unlike the Mismatch Error revision, the Calibration Mismatch Error is a hardware failure that affects the module itself. Unfortunately, this issue cannot be fixed by porting the module to another EQUALINK system:

In this case, the module must be replaced by a corresponding replacement module.

**The alternative method: Using the EQUALINK Programmer Windows software**

The EQUALINK Programmer software can be used with both, the EQUALINK Webmanager budget as well as the EQUALINK Kit. In addition to the corefunction of addressing modules and preparing them for operation, the EQUALINK Programmer software also offers interesting features helpful for error diagnostic and the detection of individual modules within a very large installation.

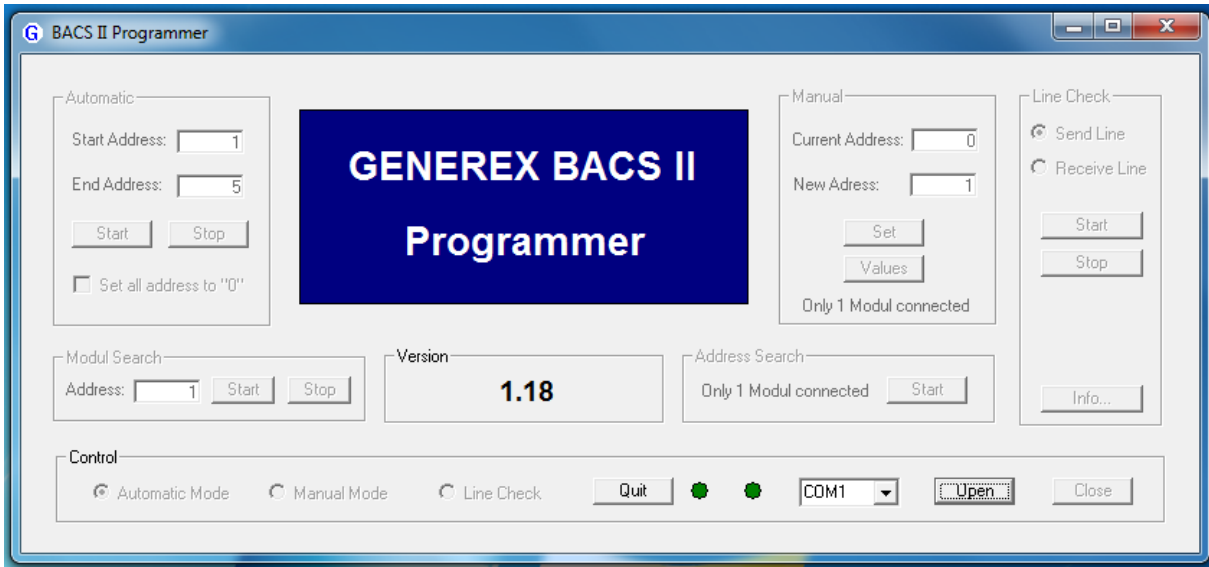

**Preparation**

This software is not a network software, you need to connect the EQUALINK Bus Converter to the COM port of your computer.

**Note**

Modern laptops often do not provide a native COM port anymore. Before your on-site visit, check if your mobile device provides such a port. If this is not the case, a suitable adapter cable can be used. Normally, this cable will be connected to the USB port and thus establish a connection between your computer and the BACS Bus Converter.



This standardized accessory for your computer is usually available from specialist retailers.

Ensure to use the supplied cable, a standard cable may fit to the ports but may have internal differences - the software would consequently suggest problems caused by an inappropriate cable:

Not every Mini-DIN / Sub D 9 pin cable can be used to communicate with the EQUALINK Bus Converter. Mark your cables to be used to avoid confusion during maintenance work.

**Connecting the EQUALINK Bus Converter**

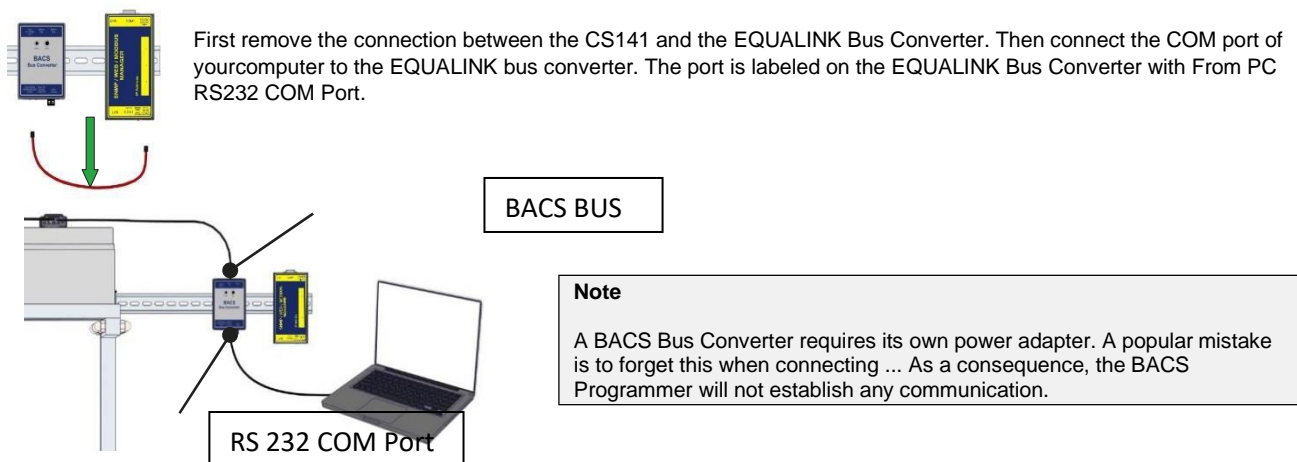

Pay attention to possible redundancies when connecting.

You do not necessarily have to decouple the entire EQUALINK system if you want to specifically check a specific section within a largesystem - but you need to ensure only one EQUALINK Bus Converter will access the tested modules:

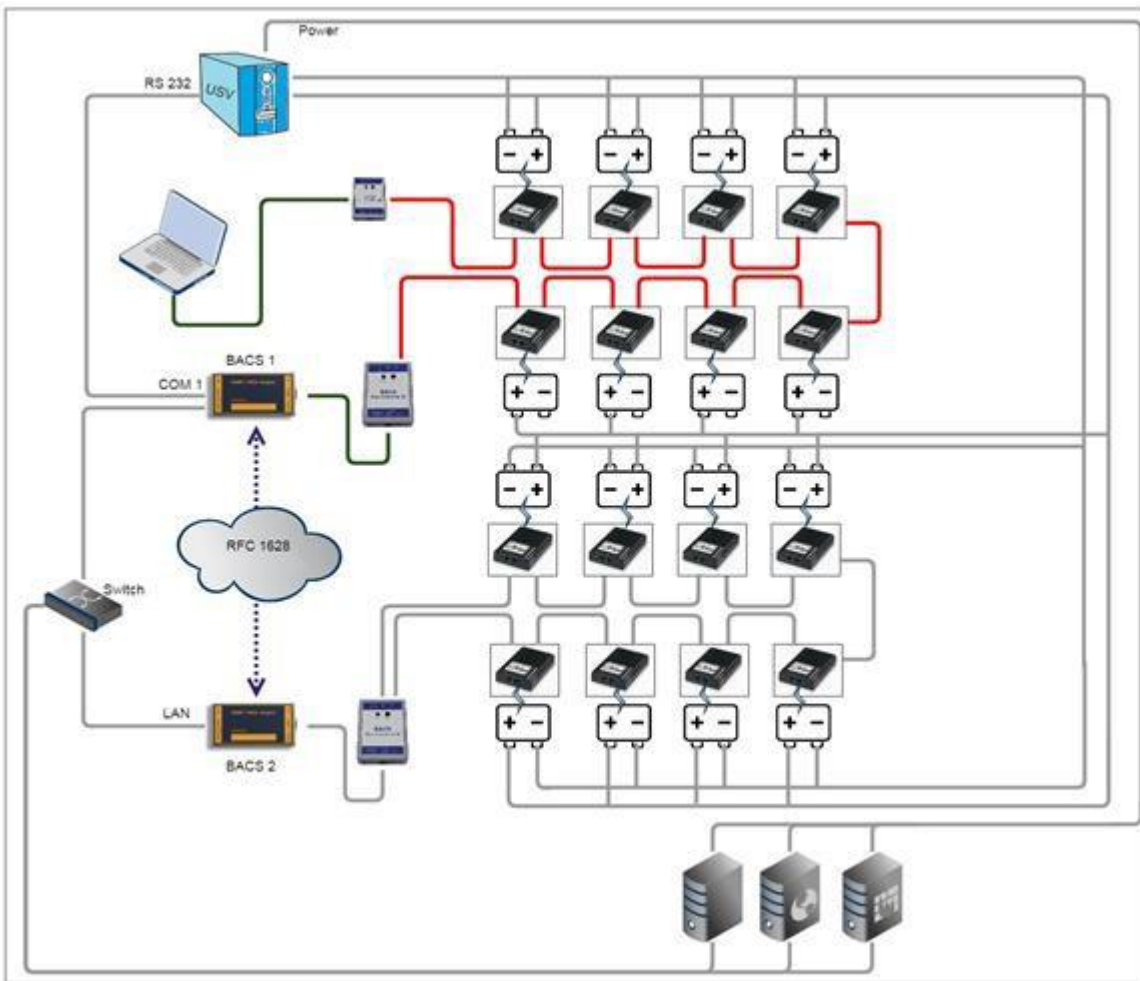

In this example, a cable was taken from the EQUALINK 1 and connected via a EQUALINK bus converter to the COM port of the laptop. In this constellation, both EQUALINK bus converters would disturb each other until the segment to be tested is completely decoupled andseparated:

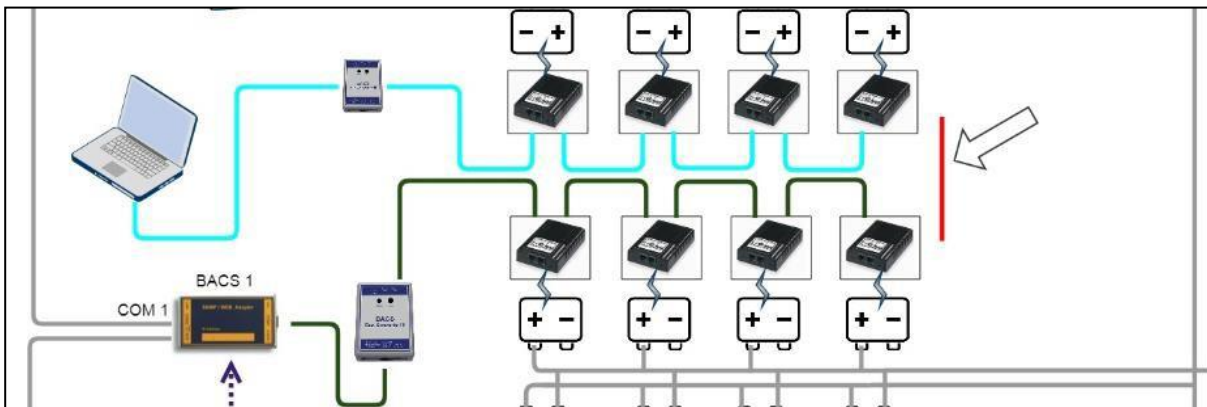

The number as well as the module ID's of EQUALINK modules that can be tested is determined by the technician who interrupts the dataconnection.

**Note**

WIf you are looking for a fault in the cabling, you should check with both, a simple and a ring cabling. If several modules are affected in the middle, you can determine the source of the error exactly from both sides. This allow you to find the affected section. However, if there is only one cable faulty, you will need the simple wiring to locate the faulty cable or module.

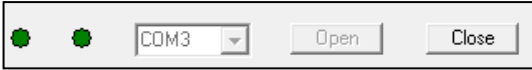

At EQUALINK II Programmer Tool, select the according COM-Port of your Computer the cable is connected to and press Open.

The button label will change to "close" and the EQUALINK Programmer will try to establish a connection to the EQUALINK Bus Converter via the serial connection.

### Toggle operating mode

#### Automatic Mode

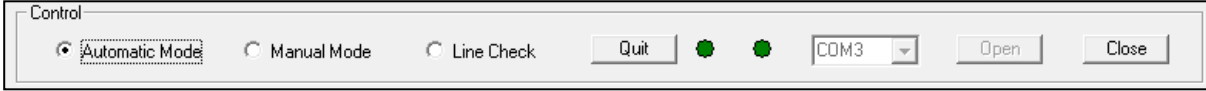

By default, the EQUALINK Programmer starts in Automatic Mode.

In order to prevent accidental incorrect entries, only the functions assigned to a specific operating mode are enabled. The automatic mode is designed for the automatic addressing of EQUALINK modules, the functionality is the same as in the EQUALINK Webmanager.

#### Manual Mode

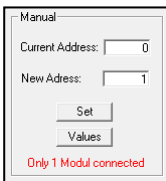
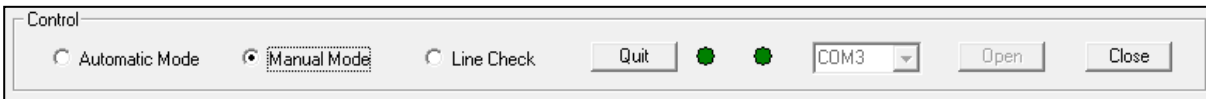

This mode describes similar functions like the single module address and search tools running on the EQUALINK Webmanager. Search for an address ID of a single module or change module addresses.



#### Searching for an installed module

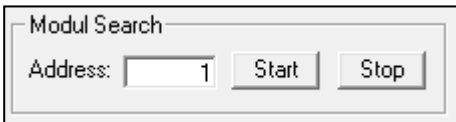

This feature will be interesting if you are inside a very large EQUALINK installation and, as an example, you are looking for the EQUALINK module with ID 378.

In this case, enter 378 and press Start. The requested module will respond with a red flash within the EQUALINK installation until you click Stop.

### Line Check

A premium feature of the EQUALINK programming software is the Line Check:

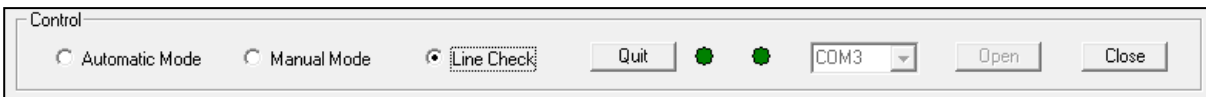

With the Line Check, EQUALINK cabling can be tested.

This test can help you to find points of weakness inside a cabling concept. As an example, this test is helpful, if

- the signal is partially disturbed caused by electromagnetic interferences (EMI) or other influences during installation not all modules are addressable.
- All modules are addressable but not found during initial start up.
- sporadic communication lost occurs

#### Operation modes of the line check

The EQUALINK Line Check offers two basic functional checks.

- Send Line Check
- Receive Line Check

### Note

For the line check tool, it is mandatory that all modules are set to factory default ID 0.



### How the send line test works

The Send Line Check is a test procedure in which all modules are addressed via a broad cast signal, starting from the EQUALINK BUSConverter.

As soon as you start this test, the Send Line Check specifies a current state that the LEDs on the EQUALINK modules should show:

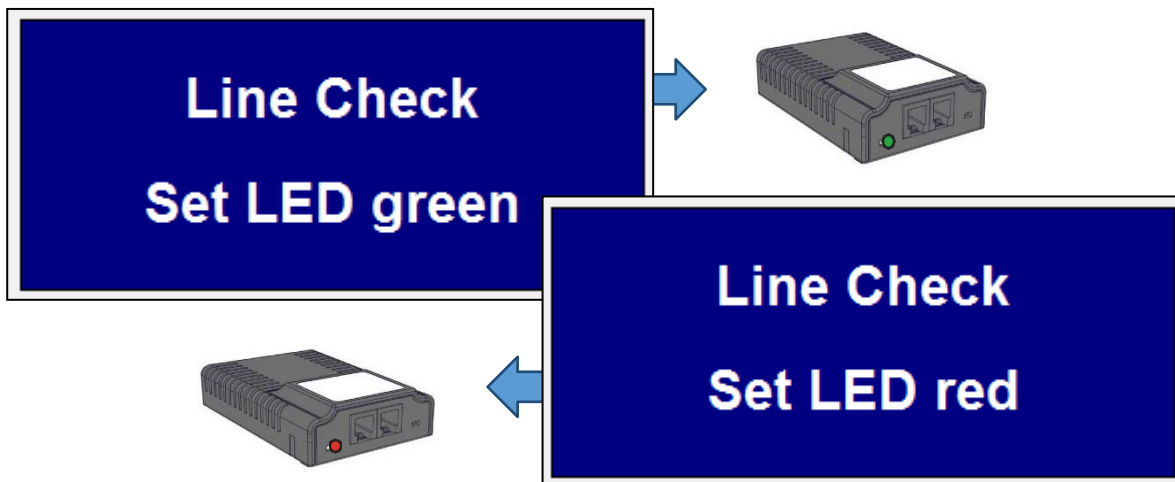

Modules that do not adhere to this guideline can be found easily. If several faults are found within a ring cabling, the outermost fault as well as a non-responding module chain is visible:

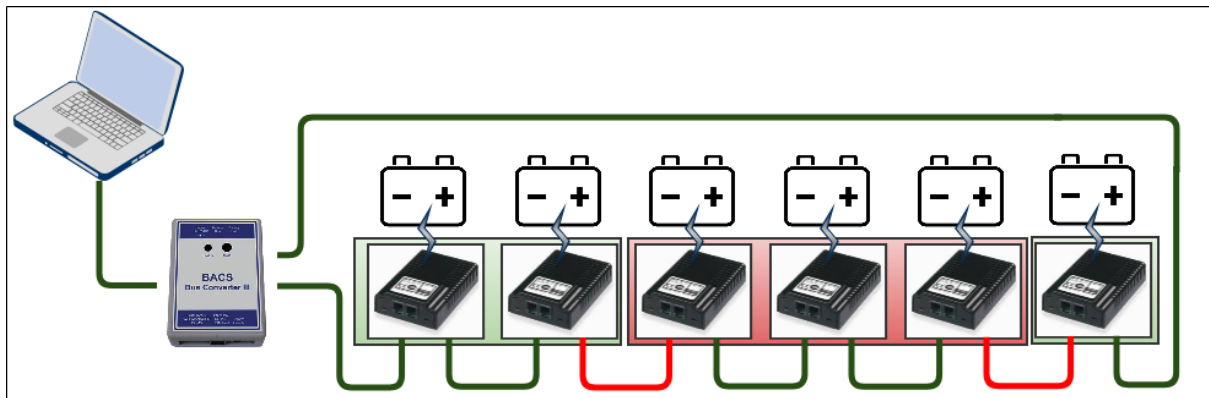

in this example, the red marked modules will show connection problems - everything between the broken cables will not be reachable. With this test, one can narrow down the sources of error, but do not clearly determine the reason for this problem. It may be...

- a broken cable
- a broken module port
- a broken port of the module before the error
- a broken module itself

The disadvantage of ring cabling while running this test, is the fact that a defective EQUALINK module would immediately attract attention, but a single defective cable or a EQUALINK module with a defective cable socket cannot appear. you need at least a completely broken module or two "half-broken" parts to find an issue:

By a single cabling defect, the redundancy behavior of the ring cabling would inevitably find all modules in the query.

### What you can do

You can perform a redundancy test on known defects and determine a general availability of all modules. By contrast, the same test running on a simple wiring:

You would only reveal the first problem inside a EQUALINK string.

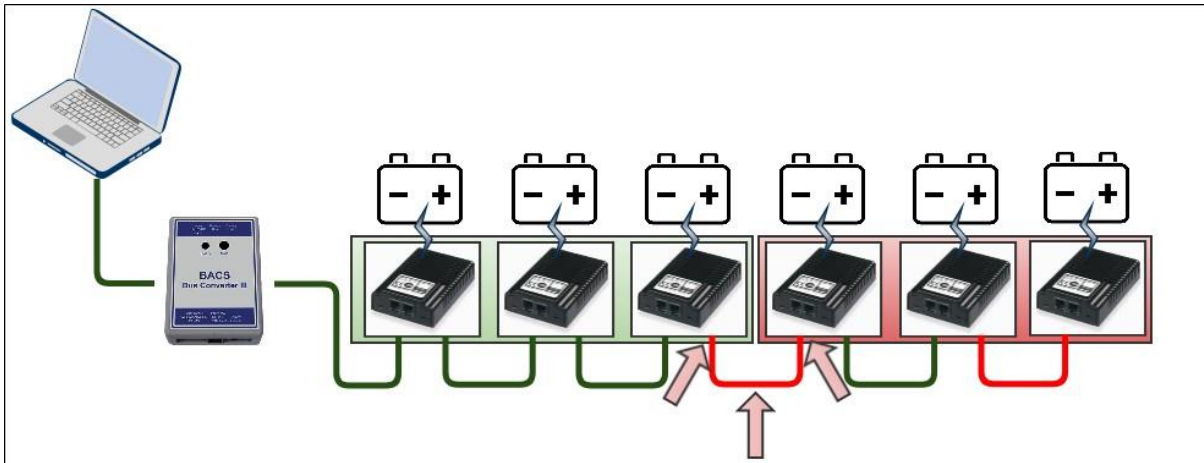

Again, you need to check whether the reason for the error can be found at the modules or the bus cables. This test reliably detects weaknesses inside an installation and will find all problems. The disadvantage is, you will always find only one problem after the other - this can take a long time.

**Note**

Both tests have their specific advantages and disadvantages. The send test coming with a ring cabling will show the general behavior and conveniently, but can only be used to find failures moderate system failures as well as broken single modules. The same test coming with a simple cabling method without a ring topology can then be used to find all problems but only the first issue in a row.

In combination, technicians can first ensure basic operations and guarantee basic availability.

**The Receive Line Test**

While the Send Line test will take care for general availability of modules and helps to find cabling issues, the Receive Line Test will take care for the quality of the data signal that will reach the EQUALINK Bus Converter.

In some cases, the cabling is well done, but the communication does not start or interrupts sporadically. This may cause as an example by strong electromagnetic interferences: EMI – In this case, the signal itself will be compromised by electromagnetic fields that will harm the conductor inside the cable and produces error bits that cannot be compensated. With the receive line test, you can take a look what happens if the last module far away from the EQUALINK Webmanager will send a data package.

*Preconditions of the test*

Please note that all modules must use the ID "0"! Otherwise this test will not work properly. If in doubt, use the Automatic Mode to set all modules to the ID "0" in advance. After resetting, proceed to the receive line test

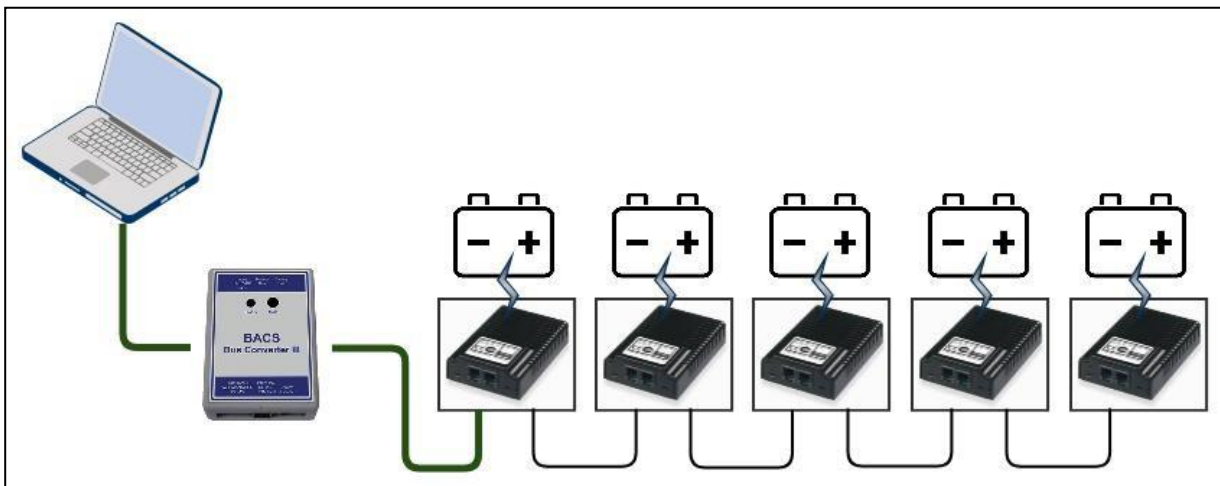

## Starting the Receive Line test

### Receive Line Check

The Receive Line Check is no longer supported by the EQUALINK modules with software version 3.4.2. Before the test, please check which hardware revision of EQUALINK modules you are using. You will find the according label on the underside of EQUALINK modules.

Please note that you cannot mix different versions within one EQUALINK bus.



the  
the

The Receive Line Check can be used to check the quality of the data signal starting from the last module in the chain.

The receive line test is a passive testing mode. The EQUALINK Programmer will not query but wait for a specially coded incoming datapacket.

When you start the test, you will not see animations or something like that, EQUALINK programmer will only show a blue center screen with white letters:

### Performing a Receive Line Check

Because you want to know something about a specific route to the EQUALINK programmer, this test will only run with a simple chain connection without any ring wiring.

1. To start the test, unplug the measuring cables to depower the EQUALINK module.

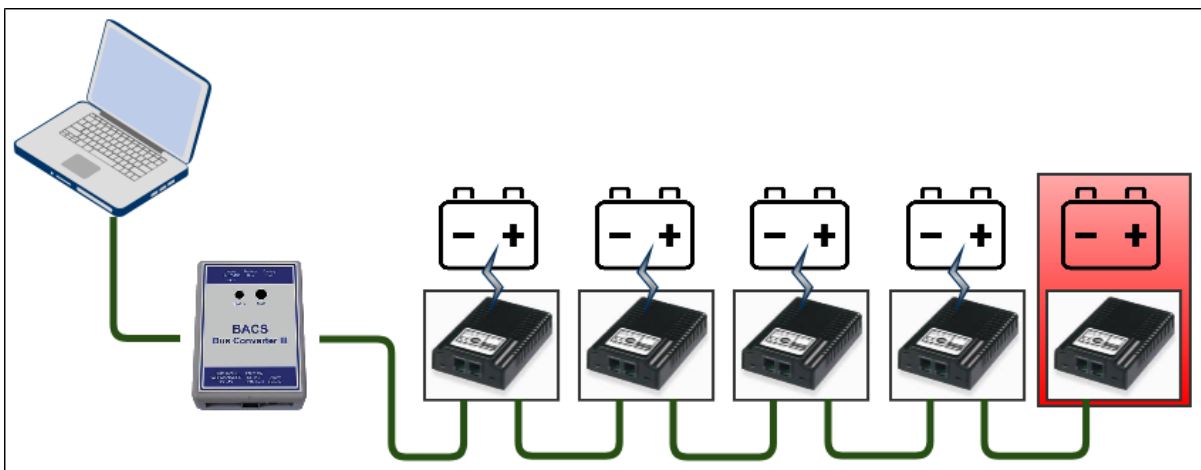
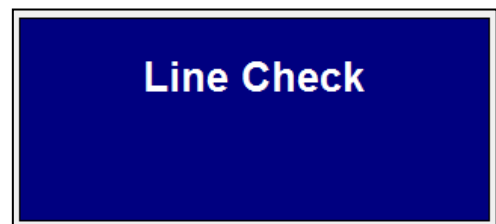

2. Press the button (yes dude, this is not the LED ...) and hold it.
3. Repower the module while holding the module button pressed.
4. Release the button. This will start the test.

### What happens:

This EQUALINK module will start sending 300 signed data through the cables to the EQUALINK Webmanager or a EQUALINK Bus Converter. This will be done sequential and evenly.

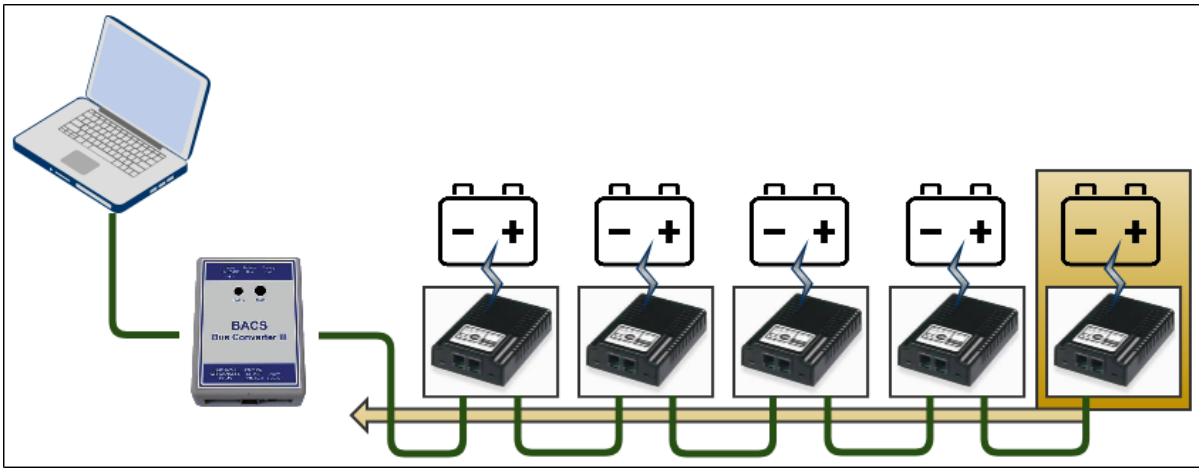

The EQUALINK programmer will notice this incoming data packets and show the number signature:

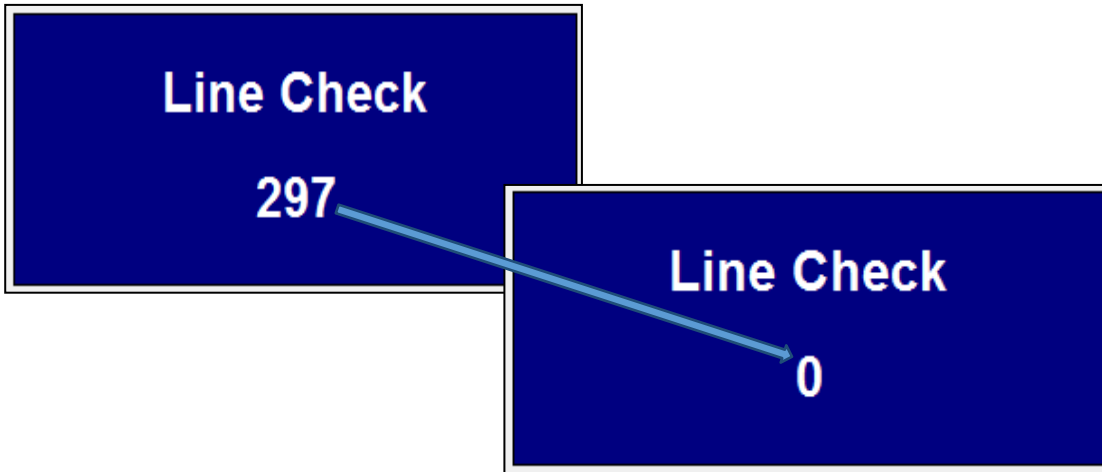

Due to the fact the data packages are signed with a unique number, it is possible to examine the quality of the data signal. In case the data packet is broken or invalid, it will be rejected.

Due to the fact you will notice following:

- The counter does not start, the screen is blank

In this case, no incoming data packets are noticed. If the send line test works as expected, please check if all modules are at default ID 0. Most common problem: Starting this test is a little bit tricky – you need to hold the button while inserting the measuring cables to repower the module. When you release the button, the test starts. If the test does not start, you cannot receive data packets.

- Jumping numbers

Yes, the test started and the last module inside the chain sends his 300 data packets. In this case there are missing or broken data packets. These packets are lost and will show, in general it may work but there is something wrong inside the cabling. To find the reason why, you may split the bac modules in two different strings and repeat the test until all numbers will be shown evenly.

- It starts counting evenly, but it suddenly stops.

This means, the chain is interrupted physically or something will block all data packets.

- It runs as expected

The numbers will be shown evenly and the countdown starts at 299 and stops with 0. Data quality is OK, all modules will respond.

Since the data packages are signed, a fault in the data line can be diagnosed very quickly because the display window counts irregularly or displays jumping numbers. If the meter stops at a number, it can be assumed that the data connection has collapsed.

**Note**

This test starts only if the trigger timing on the last BACS module is consistent. If the test does not start, first make sure that the test was triggered correctly. Otherwise, the Receive Line Check will indicate a fault in the BACS cabling.

## GX\_R\_AUX

The GX\_R\_AUX is the digital EQUALINK version of the former CON\_R\_AUX for the CS121series, which can be connected directly to the CS141. This device offers switching relays as Output and dry contacts as Input to connect external devices to the EQUALINK/CS141 system.

The overall configuration process is similar, but the GX\_R\_AUX provides some advantages like the option to integrate up to 4 of these devices into one EQUALINK bus -this will allow up to 16 inputs and outputs in total.

Due to the fact they are freely configurable, that can be used to switch and monitor many functions including other systems.

The GX\_R\_AUX devices are designed to be used a modular. They do not need to be installed all together at a single place - Install or move them during maintenance work anywhere within the installation inside the EQUALINK bus.

Due to the fact the GX\_R\_AUX is supplied with the necessary operating voltage via the EQUALINK bus cabling, there are no further livecables that need to be installed separately\*.

Thanks to the modular concept, the GX\_R\_AUX is an optional accessory to extend the scope of functions and activities of your EQUALINK installation by many additional possibilities and can be used for both – the EQUALINK installation as well as advanced CS141 configuration to communicate with child- and parent surveillance and monitoring systems as well as to trigger and monitor third-party devices. All you need to do is to put the GX\_R\_AUX to its own little EQUALINK strain.

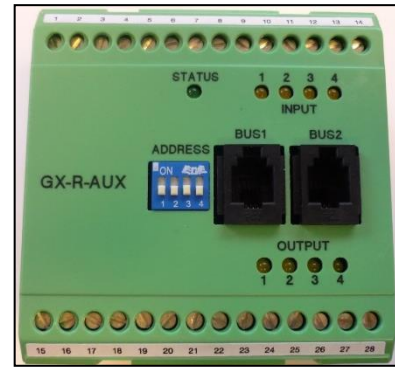

### Note

The GX\_R\_AUX makes it possible to configure battery systems according to the US standard "International Fire Code IFC 608.3". This standard defines, in case of a malfunction in coming with a possible impending Thermal Runaway threat, the batteries have to be completely isolated automatically. The use of the GX\_R\_AUX allows activation of battery separators and thus meets the requirements of the US Standard International Fire Code IFC 608.3. In case of an impending Thermal Runaway, the GX\_R\_AUX can trigger

battery separators or send an opening signal through alarm contacts in order to disconnect the battery system from the charger so the batteries cannot heat up anymore.

*\*) For more information, please refer the EQUALINK FAQ at the end of this manual.*

## Connectors

*Screwed Connections 1-14:*

*Ports 1-14 are located on the side marked as input. Port 1 is located on the left side when viewed directly from above.*



*Screw terminal layout pins 1 - 14*

1. Reserved for future developments.
2. Reserved for future developments
3. Digital Input 1
4. +12V (voltage for input 1)
5. Digital Input 2
6. +12V (voltage for input 2)
7. Digit input 3
8. +12V (voltage for input 3)
9. Digital input 4
10. +12V (Versorgung für Eingang 4)
11. Alternative EQUALINK bus +12V voltage
12. Alternative EQUALINK bus data input
13. Alternative EQUALINK bus data output
14. Alternative EQUALINK bus ground

*Pin 11 – 14: Alternative EQUALINK Bus*

In some cases, it may be necessary to connect EQUALINK devices directly via contacts. To provide this additional function, ports 11 to 14 can be used in case of the device is not connected to the EQUALINK bus via the "BUS 1" or "BUS 2" plug.

Center console

The address switch: The DIP bank "Address"



In contrast to the EQUALINK modules, the GX\_R\_AUX must be configured to its own ID. This will be done via the DIP switches. The following DIP settings are valid:

DIP 1	DIP2	DIP 3	DIP3	GX_R_AUX device ID
off	off	off	off	GX_R_AUX will be set to ID 1
ON	off	off	off	GX_R_AUX will be set to ID 2
off	ON	off	off	GX_R_AUX will be set to ID 3
ON	ON	off	off	GX_R_AUX will be set to ID 4

Please note that the ID, like a EQUALINK module, requires a unique ID, which must be set consecutively starting with ID 1. The difference to the EQUALINK module is that the GX\_R\_AUX ID is set directly via the DIP bank and can not be managed via the EQUALINK Web Manager - whereby the base address range used differs from the EQUALINK modules.

Therefore, the EQUALINK module with the ID 1 cannot be confused with the GX\_R\_AUX ID 1.

*Connecting the GX\_R\_AUX to the EQUALINK Bus*

The GX\_R\_AUX can be used everywhere inside a EQUALINK bus - Simply connect the module between two EQUALINK modules. The GX\_R\_AUX fits seamlessly into the EQUALINK bus and can be used immediately.

*Output connectors*

*Screwed connectors 15-28*

The ports 15-28 are on the side marked as output. Terminal 15 is in direct view from the top on the left side, in opposition to input 1.



*Screwed connectors 15 - 28*

- 15. Relay contact 1 No\*
- 16. Relay contact 1 NC\*\*
- 17. Relay contact 1 Common
- 18. Relay contact 2 NO\*
- 19. Relay contact 2 NC\*\*
- 20. Relay contact 2 Common
- 21. Relay contact 3 NO\*
- 22. Relay contact 3 NC\*\*
- 23. Relay contact 3 Common
- 24. Relay contact 4 NO\*
- 25. Relay contact 4 NC\*\*
- 26. Relay contact 4 Common
- 27. Relay contact
- 28. Relay contact

\*NO: normally open contact

\*\*NC: normally closed contact

## Note

If the labels and labels have been removed, you can still clearly identify the numbering of the screw terminals based on the position of the LEDs: On one side you have 5 LEDs - 4 grouped and one separated. The separate LED is the status indicator.

Align the GX\_R\_AUX in a way that the 5 LED's are in the upper side.

From now, you can easily numerate the terminals you are looking for:

The upper screw bar is numbered from left to right in ascending order, the first connection on the left outside defines 1. Furthermore, the upper bar defines the input bar.

The DIP switches are numbered from left to right in this orientation, from left to right: 1, 2, 3, 4

The bottom screw bar starts on the left side with the number 15 and is incremented to the right continuously. the bottom screw bar defines the outputs

## GX\_R\_AUX Configuration guide

For this configuration step, navigate to the following menu:

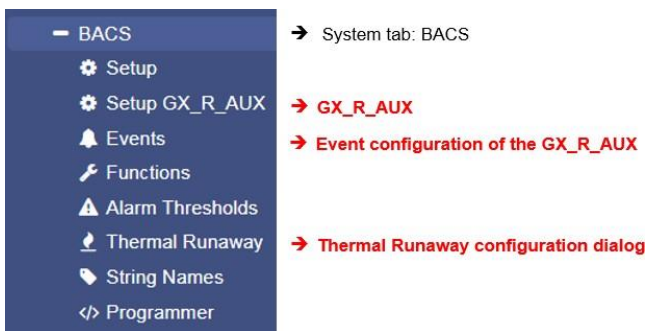

### Step 1 - Setting up a mandatory GX\_R\_AUX ID

Set up a corresponding ID - the ID's you choose has to start with 1 and ends with a number according to the number of GX\_R\_AUX you wish to use. Please note the following conditions:

- An ID may only be assigned once
- The first device receives the ID 1, then it is consecutively numbered
- Do not use more than the maximum of 4 GX\_R\_AUX within one EQUALINK installation.

### Step 2 - At EQUALINK Webmanager, open the GX\_R\_AUX configuration dialog

In the configuration dialog, you can use the EQUALINK Webmanager to specify the number of installed modules:

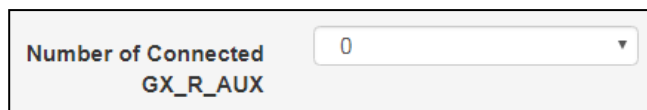

Enter "0" to disable the function. Otherwise, set the number of used GX\_R\_AUX modules and click Apply. Due to the fact new devices have been added to the EQUALINK bus, the web manager must reboot EQUALINK to find and initialize the new devices accordingly. This procedure will only restart required services, neither the Webmanager itself nor the UPS will reboot.

## Note

The BACS Webmanager will program the ID of a GX\_R\_AUX - the ID will be set by the DIP switch bank. After setting up the hardware ID of the GX\_R\_AUX, the Webmanager will be configured to search for the specific number of GX\_R\_AUX that are placed inside the BACS installation. If the estimated number of GX\_R\_AUX is not found, a corresponding error message will occur.

You can follow the success of the initialization in the upper task bar.



## How to set up the outputs of a GX\_R\_AUX as battery breaker

### Under Thermal Runaway, activate the battery breaker functionality

Before configuring the GX\_R\_AUX outputs and associated events, you need to decide if and how many battery breakers you need. Open the Thermal Runaway configuration dialog - the battery breaker configuration is mostly done automatically, which manifests itself in subsequent configurations:

1. According outputs will be labeled automatically
2. Events and jobs assigned to a Thermal Runaway are automatically entered

The total number of required battery breaker depends on the number of strings you configured at EQUALINK general setup.

Battery Disconnect

Do not trip Battery-Breakers

Trip single Battery-Breaker for all strings

Trip separate Battery-Breaker for each strings

If you want to use one battery breaker for the complete installation, select the option *Trip single Battery-Breaker for all strings*.

If you want to use a single battery System, select the option „Trip separate

Battery Disconnect

Do not trip Battery-Breakers

Trip single Battery-Breaker for all strings

Trip separate Battery-Breaker for each strings

breaker for each string installed in your EQUALINK Battery-Breaker for each string

Press *Apply* when ready.

### Under Setup GX\_R\_AUX, you will find new entries:

Output	Name	NC Contact
1	Trip Battery-Breaker String 1	<input type="checkbox"/>
2	Trip Battery-Breaker String 2	<input type="checkbox"/>
3	Trip Battery-Breaker String 3	<input type="checkbox"/>
4		<input type="checkbox"/>

As you can see, EQUALINK auto-labeled your GX\_R\_AUX Outputs according to your settings. You cannot re-label them - they are reserved for the battery breakers. Please note: If you use battery breaker, ensure, the NC Contact Flag is not set!

Again, press *Apply* when ready

### How the EQUALINK Webmanager will count the battery breaker:

The first battery breaker will be associated with output 1. From there onwards, all battery breaker will be counted one by one. If several AUX are in use, the 5th battery interrupter is configured on the 2nd AUX, Port 1. The classification as battery breaker will exclude any existing configuration - the configured output can only be used for the according battery breaker. Furthermore, depending on the number of GX\_R\_AUX devices, an individually configured additional configuration dialog will appear:

Name the inputs and outputs in free text. These labels can be found next to the inputs and outputs at the GX\_R\_AUX - Monitor:

GX_R_AUX Status						
GX_R_AUX 1						
Input	Name	Status	Output	Name	Status	
1	test	<span style="color: green;">●</span>	1	Trip Battery-Breaker String 1	<input type="radio"/>	Switch On
2		<span style="color: green;">●</span>	2	Trip Battery-Breaker String 2	<input type="radio"/>	Switch On
3		<span style="color: green;">●</span>	3	Trip Battery-Breaker String 3	<input type="radio"/>	Switch On
4		<span style="color: green;">●</span>	4		<input type="radio"/>	Switch On

### Normally Open / Normally Closed

If you do not use battery breaker you may use the outputs freely. Depending on your settings, the behavior of the EQUALINK Webmanager changes when dealing with contacts:

### NC / NO input configuration

The inputs provide to connect any potential-free switch contacts. It can be distinguished whether a contact must normally be closed (NC) or open (NO). By Changing from NO to NC behavior, it is possible to harmonize the contacts to third party devices.



A switching state in opposition to the configuration is provided with a red alarm marker:

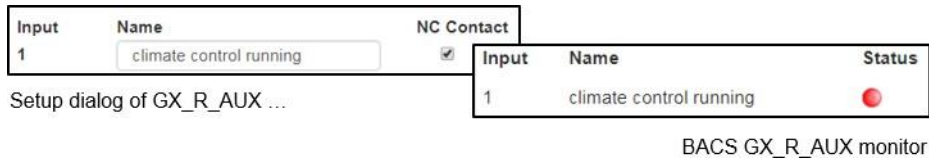

In this case, the climate control will close the contact if running. Otherwise the Status is marked red – the climate control is off.

*NC / NO output configuration*

The outputs can be assigned via the terminal strips 15-26. This option defines if a contact is generally closed and needs to be opened or open and has to be closed. During the EQUALINK initialization, the switches automatically take the correspondingly configured switching states.

Please note:

A NO - normally open - contact is open at system startup and **must be closed /turned on** accordingly:



An NC - normally closed - contact is closed at start up and **must be switched to off / open** accordingly

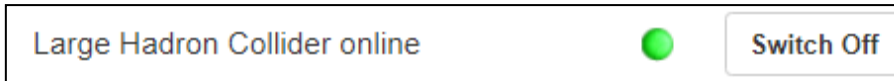

Depending on the configuration, the marker is green (active) or grey (disabled).

**Defining jobs to GX\_R\_AUX input events**

EQUALINK use a stand-alone event and job management.

This allows to use a EQUALINK system completely without a UPS connection in stand-alone operation and use its own sensors. To define a job, open the events menu in the EQUALINK configuration menu and search for the following entry:

>	<input type="checkbox"/>	+	<input type="checkbox"/>	BACS GX_R_AUX 1 Input 1 Alarm Off	3	1	0	1	0
>	<input type="checkbox"/>	+	<input type="checkbox"/>	BACS GX_R_AUX 1 Input 1 Alarm	3	1	0	1	0
>	<input type="checkbox"/>	+	<input type="checkbox"/>	BACS GX_R_AUX 1 Input 2 Alarm Off	3	1	0	1	0
>	<input type="checkbox"/>	+	<input type="checkbox"/>	BACS GX_R_AUX 1 Input 2 Alarm	3	1	0	1	0

EQUALINK GX\_R\_AUX 1 defines the module assigned with the ID 1 via the DIP bank. If you have more modules in use, they will be listed automatically as AUX 2, AUX 3, and AUX 4 inside the event menu.

The current alarm ON/Off state will be determined by NO / NC contacts definition at GX\_R\_AUX setup. At the event handling, it is possible to configure what will happen at the current contact state.

**Note**  
 The word "alarm" itself is relative meaning in this context. You can also communicate with other devices through the inputs and, for example, get switching confirmations - you are not forced to use this as an "alarm" notification.

*Setting up a job*

In this example, a log entry job is set to Input Port 1.

To enter a new job, select **+** at Input 1 Alarm – this will open the job configuration dialog:

1. As Job, choose „Log “:



The screenshot shows a configuration dialog with a label 'Job' and a dropdown menu. The dropdown menu is open, showing the word 'Log' as the selected option.

With the job type, the parameters will be adapted automatically. In this case, you can type a free text messages that will appear at the event log if GX\_R\_AUX 1 input port 1 reports a closed alarm contact position:

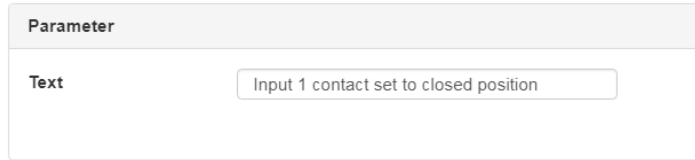

The screenshot shows a configuration dialog with a label 'Parameter' and a text input field. The text input field contains the text 'Input 1 contact set to closed position'.

Timing will allow to define when this job shall be executed. In this case, the job is executed once, at the precise moment when the defined alarm behavior occurs. For more information, please refer to the chapter event handling at part 1 of this manual.

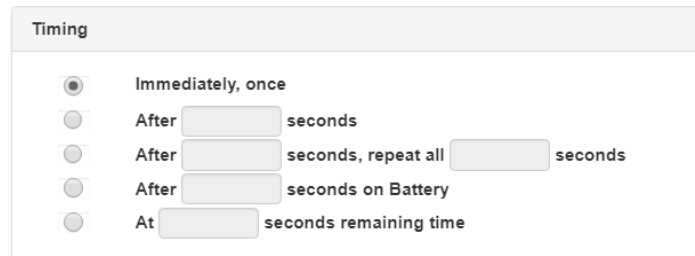

The screenshot shows a configuration dialog with a label 'Timing'. It contains five radio button options: 'Immediately, once' (selected), 'After [input] seconds', 'After [input] seconds, repeat all [input] seconds', 'After [input] seconds on Battery', and 'At [input] seconds remaining time'.

With save, the job will be written to the configuration file and executed as soon as the according event occurs. You do not need to restart the CS141 / EQUALINK Webmanager.

Checking the job configuration:

To test the job, unfold the event *BACS GX\_R\_AUX 1 Input 1 Alarm* by clicking



Your new job will be displayed:



The screenshot shows a summary bar for the job configuration. It contains three main sections: a left section with edit, delete, and play icons; a middle section with the text 'Log'; and a right section with the text 'Einmal, sofort' and a text message in curly braces: {"text": "An Input 1 wurde der Kontakt geschlossen!"}.

At this menu, you can edit, delete or test the job. More information can be found at event handling configuration in part 1 of this manual.

#### Communicate with third party devices via GX\_R\_AUX outputs

In this example, a third-party monitoring device shall be triggered by AUX output port 1.

1. Choose the event that shall trigger the output and press **+** to start the job configuration dialog
2. As job, choose AUX:

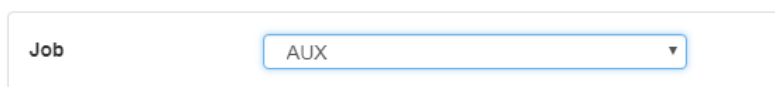

The screenshot shows a configuration dialog with a label 'Job' and a dropdown menu. The dropdown menu is open, showing the word 'AUX' as the selected option.

Depending on the number of installed GX\_R\_AUX modules, you can select an individual port from the list: In this example, GX\_R\_AUX 1, Port 3 is selected.

By doing so, use at GX\_R\_AUX output screw bar these screw connectors:

- 21 Relay contact 3 NO\*
- 22 Relay contact 3 NC\*\*
- 23 Relay contact Common

The wiring method determines what will happen in case of the command „Set High (On) “:

- NO <-> Common
- On trigger, the contact will be closed

NC <-> Common

On trigger, the contact will be opened

The standard configuration for these contacts is NO <-> Common. For this example, Port 3 will be closed as soon as the according event will occur.

Parameter	
Port Number	GX_R_AUX 1, Port 3
Command	Set High (On)

Timing will allow to define when this job shall be executed. In this case, the job is executed once, at the precise moment when the defined alarm behavior occurs. For more information, please refer to the chapter for advanced event handling at part 1 of this manual.



Timing	
<input checked="" type="radio"/>	Immediately, once
<input type="radio"/>	After <input type="text"/> seconds
<input type="radio"/>	After <input type="text"/> seconds, repeat all <input type="text"/> seconds
<input type="radio"/>	After <input type="text"/> seconds on Battery
<input type="radio"/>	At <input type="text"/> seconds remaining time

With save, the job will be written to the configuration file and executed as soon as the according event occurs. You do not need to restart the CS141 / EQUALINK Webmanager.

Checking the job configuration:

At the according event, click  to unfold the job list configured to this event:

The new job should be added accordingly:

			Log	Einmal, sofort	{ "text": "BACS started" }
			AUX	Einmal, sofort	{ "port": "102", "on_off": "1", "text": "BACS started" }

From here, you can edit, delete and test the job. Results can be seen at the GX\_R\_AUX monitor as well as event chains may be triggered.

**Note**

For the complete description of event handling including all symbols, please refer to page 58 of this manual, chapter:

***System event handling***

## EQUALINK Functions

For this configuration step, navigate to the following menu:

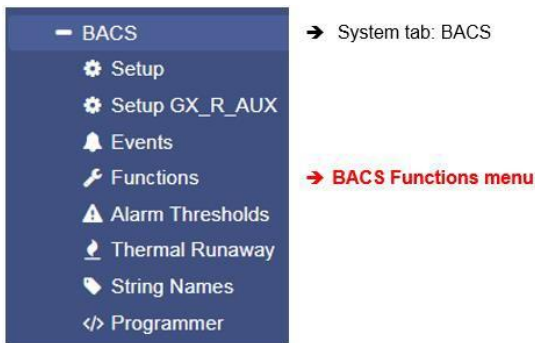

Each EQUALINK Webmanager offers basic functions that can be switched on or off remotely via the web interface.

### EQUALINK Buzzer

This internal alarm provides a clear audible warning signal as soon as there is a problem with your EQUALINK system or the connected sensors occurs or in the case of a so-called General Alarm.

As a default, the buzzer will be triggered in case of the event „EQUALINK General Alarm “.

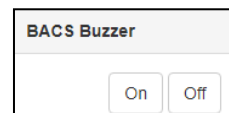

### EQUALINK Relay

Parallel to the alarm buzzer, EQUALINK provide an internal relay:

With this relay external monitoring systems can be informed that something went wrong. The internal EQUALINK alarm relay is linked to a general alarm and cannot be configured:

The relay is a pre-defined normally closed contact, which automatically picks up about 15-20 seconds after system startup and is only reopened in case of a system fault:

1. A EQUALINK General Alarm is in progress
2. The EQUALINK Webmanager or EQUALINK Bus Converter is depowered.



Master alarm will start, if ...

- Voltage alarm high/low,
- Temperature alarm high/low
- Impedance alarm high/low
- Communication lost to one or more modules or a system alarm is in progress
- Thermal Runaway alarm
- Equalizing / Balancing Error alarm
- String voltage alarm

#### Note:

If you manually open the relay, it remains open until one of the following conditions is met:

- The device restarts (by rebooting via software button or in case of a cold boot).
- An active BACS-alarm falls back to normal state (voltage measurements reach alarm levels and drops below).
- It will be closed via BACS relays functions menu.

### EQUALINK alarm thresholds

In principle, there are two points during usage, that may heavily damage the Batteries of a UPS system:

#### Overvoltaged Batteries

The overvoltage occurs if a UPS initiates a boost charging cycle to restore emergency power time as fast as possible after a discharge. As an example, the charging process will be done with a boost charge or operates with predefined charging voltage.

In both cases, the reference charging point is the slowest loading battery to rule the entire charging process.

As result, normal or fast charging Batteries are consequently overcharged, leading into average temperature issues and as a long-term consequence, overcharging the cells in the battery are damaged through the dehydration process coming with abnormal temperature usage. Overcharging will damage the battery, but this is not enough:

As a consequence of an overcharge, a battery will heat - this may lead into a dangerous battery overheating and fire issue. Conversely, a battery damaged by overvoltage can subsequently not meet the requirements set, which leads to different behavioral characteristics:

- Extended loading time
- Permanently performance decrease
- Temperature increasing with each charge/discharge cycle
- Sporadically dropping below the discharge end voltage
- Lapsing service time
- Overheating and acute fire hazard.

Which defects occur exactly depends on the type of battery as well as the basic conditions. Overloading should, if possible, be avoided for these reasons.

**Deep discharge**

During deep discharge, a cell of a battery is discharged during use until a complete depletion. In case of a deep discharge, the voltage drops below the final discharge voltage, a condition in which a wide variety of defects may occur. Depending on the type of battery even a single deep discharge can damage the battery internally so that it can lead into a total failure or even a polarity reversal of the battery contacts.

Reloading damaged battery can be very dangerous because the reaction to the charging current unpredictable:

Although the battery is faulty, it initially appears to be responding normally to the charging process initiated by the UPS - a creeping malfunction can appear up to 16 hours after charging is complete. Everything may happen, starting at an acute overheating when starting or during charging process as well as a seemingly sporadic phenomenon during charging that leads creeping into a fire issue many hours later.

**Note**

Typically, a UPS will stop operating in time to avoid this deep discharge, but overvoltage or undervoltage that weaken the cells, cannot be detected the UPS.

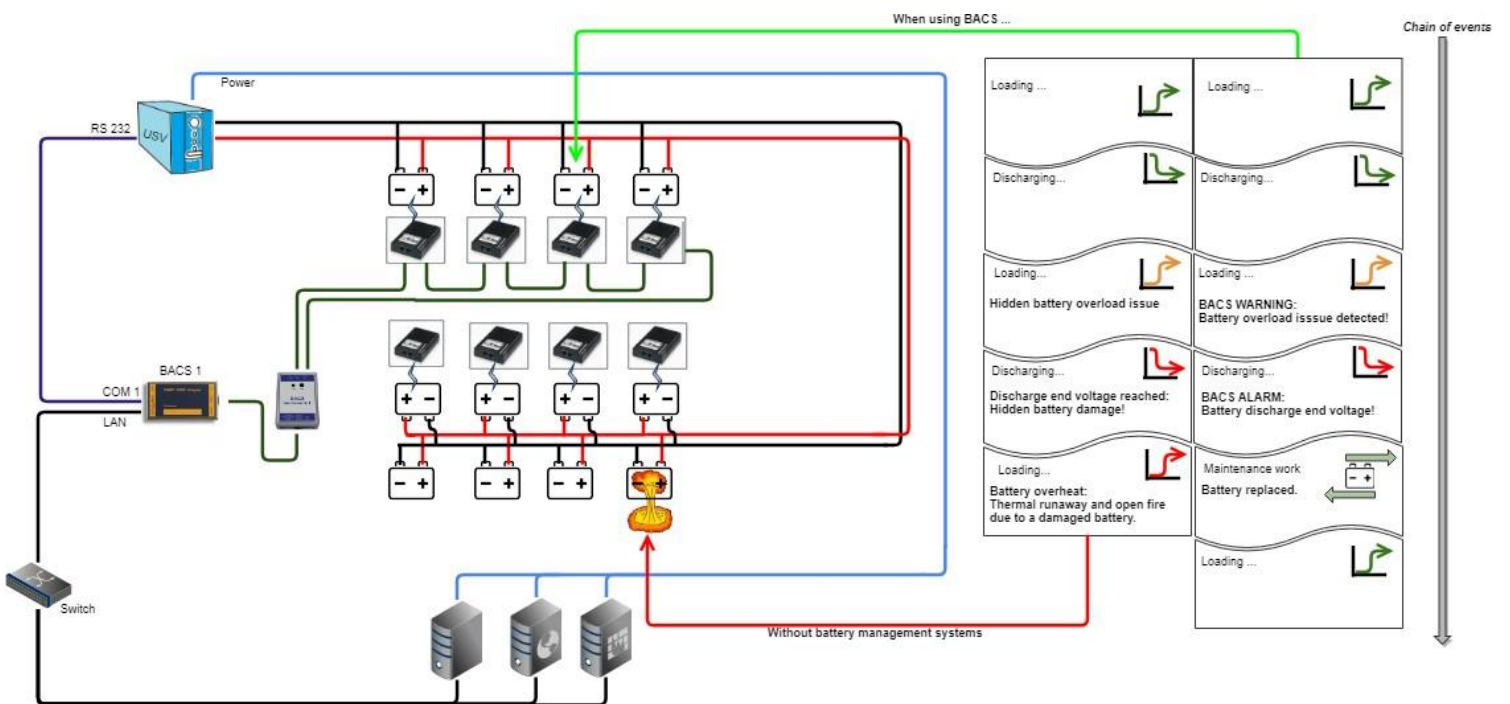

## Threshold definitions

For this configuration step, navigate to the following menu:

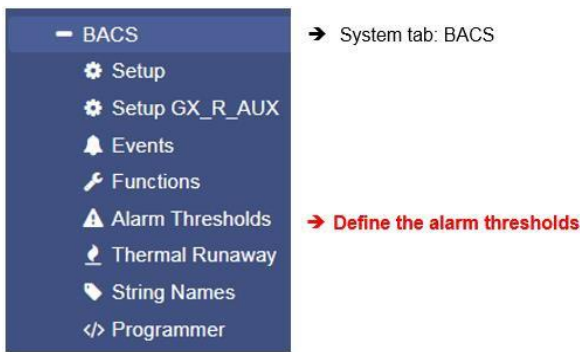

The EQUALINK thresholds define fixed points within the charge / discharge cycle where intervention becomes necessary before an acute incident arises.

The following values are monitored during the discharge / charge cycles:

Warning Levels			
	Min	Max	
Voltage	10,5 V	14,1 V	→ Battery voltage
Temperature	10 °C	30 °C	→ Battery temperature
Impedance	1,2 mΩ	40 mΩ	→ Internal resistance of the battery
Enable Max. Voltage Difference	<input checked="" type="checkbox"/>	0 V	→ Voltage deviation between batteries
Baseline Impedance	25 %		→ Baseline Impedance in %
Enable String Thresholds	<input type="checkbox"/>		
String Voltage	0 V	1000 V	→ Voltage deviation between battery strands
Enable Current Thresholds	<input type="checkbox"/>		
String Current	-10 A	10 A	→ Current deviation between the battery stands

### Battery voltage

The voltage measured by a battery during the charge / discharge cycle indicates whether the battery will soon become overcharged or will run into a deep discharge. These values may differ depending of the specifications made by the battery manufacturer. In case of the measurements exceed or drop below the pre-defined values, a warning will be issued.

Please note, the limits specified by the EQUALINK are correct for most Batteries and should only be changed after consultation with the battery manufacturer.

### Battery temperature

The temperature of a battery will influence the performance and the life of a battery. A battery will heat up during the charge and discharge cycle. However, if the temperature exceeds the limits, it may lead into different defects. How and when these defects will manifest, depends on the type of battery.

### Internal resistance of the battery

Depending on the design of the battery, the internal resistance changes, in some cases it increases abruptly, in other cases it drops abruptly. In case of using new Batteries, measured values of the internal resistance should always be equal at all Batteries. Thereby the measured value is determined by its carrier material - the type of battery. This means, a deviation of the internal resistance to other Batteries indicates a battery fault.

Why not using voltage measurements?

The voltage is not suited to be used as an indicator for battery failure, because measured voltages of the battery reacts and follows during a trickle charge the voltage behavior of the charger. With internal resistance (and the indicator for equalizing) measured values will indicate a problem of the Batteries' chemistry and thus allow to warn in case future problems can be assumed.

The internal resistance of a battery indicates upcoming problems and should be used for long term monitoring.

For warning level, we recommend 25% deviation from the average value of all Batteries.

For alarm levels, we recommend 50 % deviation from the average value of all Batteries.

**Attention:**

Each battery manufacturer uses an own measuring method to get the impedance values for a data sheet. As a consequence, it is possible that taking impedance values from the battery manufacturer's data sheet is not suitable to configurate BACS thresholds:

To ensure save operation, determine impedance values for BACS as described in this manual.

*Maximum Voltage deviation between Batteries*

Batteries must be used regularly, the charge / discharge process is very important for optimal operation.

Despite equalizing / balancing, an unused battery loses its target voltage over time, although it receives a trickle charge from the UPS. This is a natural process and not a malfunction:

If the fluids in the battery come to rest, gravity affects the fluids inside the battery:

Basically, liquids of different molecular weight in a standing system tend to be arranged according to their molecular weight over time. The heavy liquid slowly sinks down while the light liquid migrates upwards. As a consequence, the overall concentration ratio of liquids changes, which impairs the efficiency. How much this natural process will take effect, depends strongly on the chemicals used as well as the size of a battery - as bigger the battery as stronger this phenomenon will take effect.

The target voltage can be normalized by regular battery use due to the fact the chemical processes cause a circulation and even distribution of all chemicals. The EQUALINK Webmanager can measure the deviation in 0.1-volt increments and give an indication if the measured voltage and the target voltage are too drifting apart.

*Voltage deviation per string*

This feature is similar to comparing individual EQUALINK voltage measurements. However, this function compares the individual strings within a EQUALINK installation.

*Current deviation per string*

Unlike the voltage, the charging current divides evenly into the different strings - but the total current will not change. Since all battery strings work evenly in the network, defects in one string will have a negative impact on all strings. EQUALINK can be adviced to measure this effect and give feedback to technical staff.

Please note, this setting requires current sensors on each string

**Note**

What is the difference between warning and alarm?

BACS distinguish between a definitive alarm that requires intervention and a warning:

Both states are quite similar, the different jobs can be freely defined for the corresponding warning or alarm level. Depending on optional parts and devices attached to BACS as well as the configuration, very delicate automatic processes can be initiated, ranging from information to the initiation of active emergency measures up to switching and controlling of systems, etc.

In the event of an alarm condition, the acoustic alarm is additionally activated, the alarm LED changes its status and the alarm contact on the BACS Webmanager is actively opened.

The values are freely definable, but care should be taken to ensure that the values for the warning are always reached well in advance of the values for an alarm so that there is still enough time for an adequate response.

**Alarm Delay**

**Alarm Delay**

Enable Discharge Volt Alarm Delay

1 Minutes

As a consequence of a used emergency power or an extended battery test, battery voltage is in low condition. If the UPS takes the maximum time for autonomous operation, it possible that the minimum values for the EQUALINK alarm will be triggered.

This option allows to set up an alarm time delay to prevent EQUALINK from sending a false alarm.

## Define EQUALINK Battery strings

For this configuration step please navigate to the following menus

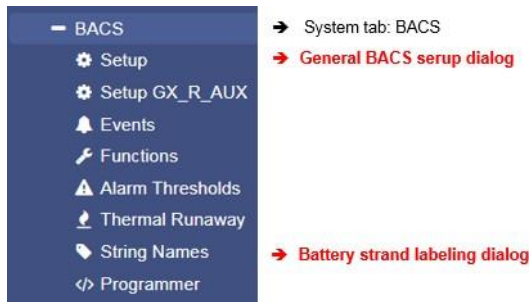

EQUALINK offers the logical assignment of the individual Batteries to so-called Battery strings.

The number of Batteries is divided by the number of specified strings. The result is the logical assignment of the EQUALINK module in singlestrings.

Example:

They have 72 Batteries and define 6 single strings. The EQUALINK system will present you with 6 battery strings of 12 Batteries each, asentered after initialization. Basically, the assignment is made according as followed:

72 Batteries divided by 6 strings will take 12 Batteries per

standBatteries 1 - 12	String 1
Batteries 13 - 24	String 2
Batteries 25 - 36	String 3
Batteries 37 - 48	String 4
Batteries 49 – 60	String 5
Batteries 61 - 72	String 6

After initialization, you will notice that EQUALINK has renamed the modules:

If you have successfully included module 49, it would now be listed at battery strings 5 as module 1.

### Note

The ID of the module has not changed, it remains the BACS module with the unique ID 49. What changed is the display context at the monitoring screen as well as general presentation of the data. Usually, the installation site and the string are coordinated so that module and string accordingly fit together.

If no project documentation exists, you can use this to identify the individual strings and search via the BACS Programmer.

Please note: The numbers of current sensors will be defined by the number of strings you define and label. You cannot define a specified number of current sensors, but you can:

- Use a current sensor for each single EQUALINK string
- Use one current sensor for all EQUALINK strings if installed at the master string
- Use one current sensor installed in one single string and use the multiplier to get information about all strings

### EQUALINK strings vs battery breaker

Furthermore, setting up EQUALINK strings will harm the battery breaker setup:

The EQUALINK Webmanager offers two options:

- One battery breaker for all strings
- One battery breaker for each string

Please note, depending on the number of strings, you may need up to 4 GX\_R\_AUX modules. The maximum number of battery breaker is 16.



## Thermal Runaway

For this configuration step, navigate to the following menu:



A "Thermal Runaway" is one of the most dangerous events that can happen when using battery systems:

The battery overheats. This incident leads into trouble with unpredictable effects:

Overheated Batteries can expel explosive, corrosive, or oxygen-displacing gases, catch fire, explode as well as damaging neighboring Batteries. Furthermore, battery caused fire also contains toxic and unpredictable mixture of chemicals, whose combustion gases, in addition to special extinguishing agents, make special protective clothing indispensable.

For this reason, some countries all around the world require in case of clear signs for a beginning thermal runaway, the Batteries can be completely separated from the UPS or the battery charging system.

### How to configure a thermal runaway

For this step, the following pre-conditions are mandatory:

1. The number of Batteries is configured
2. The number of battery strings is configured
3. Ideally, the strings are named
4. All EQUALINK modules are registered, found and EQUALINK is initialized and running.
5. Battery breaker are installed
6. GX\_R\_AUX are installed and ready to use

Open the tab „Thermal Runaway “:

At first, define the condition a EQUALINK Webmanager shall assume a Thermal Runaway:

Max. Module Temperature Difference	<input type="text" value="20"/>	*C	→ temperature difference between BACS modules
Optional: Max. Current per String	<input type="text" value="10"/>	A	→ Current difference between strands*
Optional: Above Conditions Are True Since	<input type="text" value="30"/>	Minutes	→ Reference time: above should be fulfilled*

\* Additional options based on the configuration and hardware-level of your EQUALINK system

### Max. Module Temperature Difference

Problems usually indicates in dramatic temperature increasments of individual Batteries. The EQUALINK Webmanager therefore measuresthe temperature of the individual Batteries on each module.

This results in a basic statistical value from which individual Batteries can deviate.

If boundary conditions are met, there is a clear indication of a thermal runaway. Depending on the hardware constellation, the protection circuitry physically disconnects affected string or all Batteries from UPS / battery charger.

### Max Current per String

Optionally, an additional conspicuousness can be included in the thermal runaway detection as soon as each string can use its own current sensor. Via the current sensor, a deviation of individual strings in relation to other strings can be measured:

Ideally, the strings are evenly loaded and unloaded. Irregularities and short-term deviations are familiar phenomena when dealing with Batteries, large and long-term deviations are an indication of a broken battery, endangered for leading into a thermal runaway...

### Above Conditions Are True Since

This feature defines timer that must be expired before the EQUALINK Webmanager considers a thermal runaway is proven. Among otherthings, this feature can be used to calculate local peculiarities and roughly predictable environmental influences.

When finished with configuration, open the GX\_R\_AUX configuration dialog

Your settings changed thee entries and fixed them to a special functionality:

**GX\_R\_AUX 1**

Input	Name	NC Contact	Output	Name	NC Contact
1	Warpkern	<input type="checkbox"/>	1	Trip Battery-Breaker String 1	<input type="checkbox"/>
2	Materie Injektor	<input checked="" type="checkbox"/>	2	Trip Battery-Breaker String 2	<input type="checkbox"/>
3	Antimaterie Injektor	<input type="checkbox"/>	3	Trip Battery-Breaker String 3	<input type="checkbox"/>
4	Magnetische Eindämmung	<input checked="" type="checkbox"/>	4	Captain Picard fragen...	<input type="checkbox"/>

Apply Cancel

All you need to do is the definition whether the battery breaker you are using are Normally Open (NO) Contacts or Normally Closed (NC) contacts. Due to the fact, both concepts are in use, EQUALINK cannot know which type of battery breakers are currently in use.

Open EQUALINK event handling and search for EQUALINK thermal Runaway String 1, 2 und 3 and unfold them:

Job Type	When	Parameter
Log	Once, immediately	{"text":"BACS Thermal Runaway String 1"}
RCCMD Trap	Once, immediately	{"text":"BACS Thermal Runaway String 1 in #LOCATION"}
EEmail Trap	Once, immediately	{}
AUX	Once, immediately	{"port":"100","on_off":"1","text":"BACS Thermal Runaway String 100"}

The EQUALINK Webmanager automatically added an AUX-Job to switch the battery breaker.

Press the test button to check whether the battery breaker will be triggered and opens accordingly. If not, you need to configure the NC/NO-Contacts of the EQUALINK GXR\_AUX to the correct position and check wiring at the device itself.

**Note**

If you configure the Thermal Runaway after configuring GX\_R\_AUX outputs, be sure to check for previously entered events for plausibility:

You may also need to open the battery interrupters for other reasons, the Thermal Runaway configuration dialog will only work on a specific scenario and configuration routine automatically:

The outputs are renamed and a preconfigured job is automatically added to the corresponding events. Since the BACS Web Manager cannot know why you entered these additional conditions, BACS will not remove all your configurations automatically-

It is up to you to check them manually.

## Maintenance: Replacing EQUALINK modules

Unfortunately, even in the best systems, it can occasionally happen that a module shows an abnormality that makes it necessary to replace it.

Replacing a EQUALINK module is easy, but you need to follow these few rules:

1. Find the module ID of the module you plan to replace  
Normally, the EQUALINK WEBMANAGER tells you which module is defect.
2. Program the module to the ID the old module uses.  
Programmieren Sie das Austausch-Modul auf die korrekte ID. Ab Werk können ist die ID 0 voreingestellt, daher können Sie entsprechend einfach über den Single Mode die ID 0 auf die gewünschte ID setzen
3. Altes Modul durch neues Modul ersetzen  
Entfernen Sie das defekte EQUALINK Modul und schließen Sie das neue EQUALINK Modul an.
4. Überprüfen Sie, ob die ID richtig ist  
Beim Start von EQUALINK dürfen
  - a. keine ID-Doubletten im EQUALINK-Bus vorhanden sein,
  - b. keine ID-Löcher im EQUALINK Bus vorhanden sein
5. Starten Sie EQUALINK neu – das neue Modul wird automatisch erkannt und abgefragt werden.

### Which EQUALINK module can be used as spare part?

In principle, you can re-arrange all EQUALINK modules as you wish as long as you use only one battery string.

But you cannot mix different hardware revisions of the EQUALINK modules! At the EQUALINK Monitor, the EQUALINK module hardware revision is provided:

Module info		Batte
Module type	C20	Manu
Hardware Version	03.02	Type
Software Version	03.02.02	Capa
Number of Blocks	3	Instal
Number of Strings	1	Phon
Contact Person		Locat
IP Address	10.10.10.10	Mac #

### Why is the revision number for this EQUALINK system correct?

During initialization phase of EQUALINK after configuration work is done, the module with ID 1 is read in and all subsequent modules are compared with this hardware revision version.

By doing so, the EQUALINK system quickly finds the wrong modules.

For more information, please refer to the chapter *EQUALINK Error: HW / Calibration error*

## EQUALINK LOG files

The EQUALINK log files provide extensive information about your Batteries managed by EQUALINK:

- temperature values
- Charge / discharge cycles
- Internal resistance of the Batteries
- Current fluctuations
- Operating time
- etc

These log files allow deep battery analyzes for both, the current system states and for any single battery state within a battery string.

In addition, these valuable data can be used to track the battery life cycle since installation and even make reliable predictions about impending failures - important information for planning of maintenance intervals.

The EQUALINK web manager has 30 MB of exclusively reserved memory in order to reliably save all EQUALINK log data.

### Rotating memory management provides maximizing available log files

With rotating storage management, the data is initially stored continuously up to the maximum usable storage size.

If the maximum available storage space is reached, the oldest entry is deleted in order to obtain the necessary space for the new data. By doing so, the EQUALINK WEBMANAGER grants a continuous data history.

### Size of the time window before the oldest log files will be erased

You can actually only estimate an average time window, because the amount of data is shaped not only by the number of modules, but also by the type of use in combination with unforeseeable incidents.

As an example:

- One single EQUALINK module ...

generates about 700 bytes in one day in normal operation without battery discharge cycles. If your system consists of only 1 module, the memory would need more than 29,000 days before the first day will be deleted to save the latest data.:

The local saved battery data log would show about 80 years - this is nearly an average human lifetime.

- A standard UPS system with 40 Batteries...

will generate with 40 \* 700 bytes about 28000 bytes per day in normal operation. The EQUALINK web manager could therefore hold and provide over 1000 days. You can assume that the 2 - 2 1/2 years are available

The crux of the standard application, however, can be found within the definition and the details of a memory calculation. In case of a discharge cycle, the data logging frequency increases in order to ensure traceability and analysis of the discharge:

Due to the increased measuring frequency during the discharge cycle, each EQUALINK module generates approx. 9300 bytes. When we assume a special and very theoretical discharge scenario (normally the Batteries are depleted long before), the EQUALINK web manager could record the discharge for a standard UPS with 40-60 Batteries in this scenario up to 17-18 hours continuously.

#### **Note:**

What is such a „theoretical discharge scenario“?

Usually, a power failure itself cannot be planned, but the batteries can be found at a foreseeable site when this happens. As soon as the EDP has been shut down, the UPS can also be switched off. How long the UPS will grant emergency power depends on the capacity of the UPS as well as the number of devices that must be fed with emergency power.

However, there is also the possibility that you have a mobile EDP system with limited main power usage that comes with the problem a hardware shutdown is not an option (e.g. a tectonic sensor grid). Minor power usage may lead into a very long emergency power operating time via the UPS. In this special scenario, the battery data can provide valuable insights to improve reliability with some limitations.

- A large UPS solution with 120 managed Batteries...

When normal operation is active, the EQUALINK WEBMANAGER would generate with 700byte \* 120 units an impressive amount of data of up to 84,000 bytes - Keep in mind that these data are not "image files", we are talking about numerical values that are in a table and can be converted into graphic tables if necessary.

In this case, the EQUALINK WEBMANAGER B4 can keep this immense amount of battery data for up to 238 days before the oldest files have to be overwritten.

The data will be available for about 7-9 months.

During a discharge, the measuring frequency is increased as described above. In a very large battery system with up to 120 Batteries, a EQUALINK web manager can still hold records of the discharging process between 8-12 hours, the amount of collected data is difficult to imagine.

To save the data permanently, the log files can be exported. How often this is necessary depends on the size and use of the entire system:

In the case of very large systems, it is usually sufficient to back up the data about once a month in order to have a closed history of all battery data in an emergency. Data from a very large system, which very often changes to the discharge state due to usage, should be saved more frequently accordingly.

What are all these data used for?

Yes, why should you keep the data ... a good question!

As already mentioned, deep analyzes and a qualified current battery system health status can be generated as well as status reports for time windows needed for the maintenance work. Indicators such as a steadily increasing internal resistance reflect the natural aging process of a battery and indicate the end of use. In case of system malfunction, all these data are also useful for a reconstruction of the incident, because the battery data help to classify the malfunction in a clear and unambiguous timeline.

They provide valuable additional insights and help to improve the safety net and demonstrate weak points within the UPS solution.

Special applications, on the other hand, can be better planned and implemented because, for example, the findings could be used within a simulation program and proof-of-concept studies can be carried out for future UPS concepts.

So there are a few reasons to back up this data - the value of this data depends on what you want to do with it.

**Note:**

After a long discharge cycle, it takes a some time for the batteries to be recharged. We recommend picking up and analyzing the data after charging process is finished:

Not only for saving data, you can also see directly whether the batteries have been correctly recharged - you will get valuable information about the current state of health of the entire system. You can instruct the BACS WEBMANAGER to inform you as soon as the batteries are fully charged.

BACS will inform you if:

- ... there are complications in which an intervention is inevitable or imminent.
- ... the loading process was successfully completed.

Retrieve EQUALINK log data

There are different options to get the EQUALINK log files

*Via Web interface*

*For this step you need the following menu:*



The EQUALINK log files can be downloaded directly from the EQUALINKLog menu.

For the evaluation, we recommend the professional analysis tool EQUALINK Viewer, which is available as freeware in the download area of our website [www.Exponential Power.de](http://www.Exponential Power.de).

*The EQUALINK WEBMANAGER provides two different options:*

:

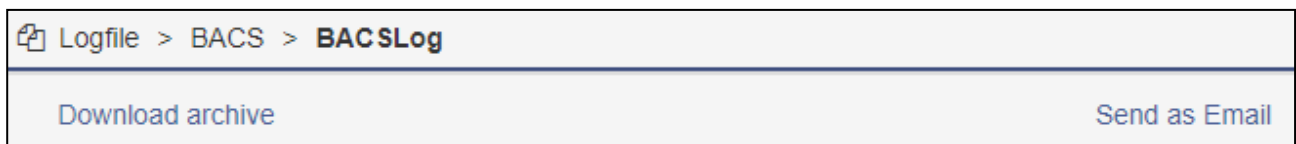

*Download archive*

You can call up all available log files directly via the integrated web interface. The data is packed in real time and the download starts automatically as soon as the file is available. Please note, that the time window to generate the data strongly depends on the amount of available data.

### Send as Email

For this function, you need to configure the build-in mail client before using this function.

The EQUALINK web manager offers you sending available log files via email to any email address. Since the data attachment can be up to 20 MB, it is recommended to limit the amount of data accordingly:

Send a compressed archive with BACS logs via email		
To	<input type="text" value="jean-luc@piccard.com"/>	→ Mailadresse des Empfängers
Subject	<input type="text" value="BACS-Log_2019-09-15"/>	→ Titel der Mail
Limit file amount	<input type="text" value="Leave blank to archive all daily log files."/>	→ Eingrenzen der Datenmenge
<input type="button" value="Send"/> <input type="button" value="Cancel"/>		→ Mail absenden/ abbrechen

Mail servers are now sensitive to large attachments, since many users have lost the feeling for file sizes - attaching content with more than 10 MB to emails may cause problems when sending and receiving emails. As a consequence, administrators and service providers have often reduced the size of the attachments. If the attachment is too large, the email will be sent without the attachments or emails will be simply refused by the incoming mail server...

With this function you can - based on a daily report - enter the desired number of hours. If you e.g. enter a 7, the EQUALINK will mail the last 7 hours.

### Note

The maximum size of the packed file is 20 MB - the real size of the file and the amount of hours that could be found within the log file depends on the type of use and the size of the files.

### Direct download via SFTP

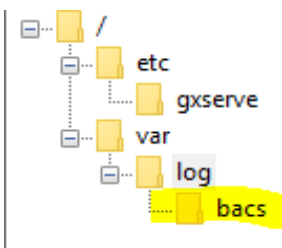

You can access the data directly via the integrated download server of the EQUALINK WEBMANAGER - use any SFTP client - there is no limitation which client you should use.

### Access data:

IP: <die IP address of your WEBMANAGER>  
Port: SFTP / Port 22  
User: admin  
Passwort: cs141-snmp or your specific admin password

After logging in, open the directory var/log - here you will find all EQUALINK log files. Simply copy the files to your hard drive - you can later evaluate the log files with professional battery analyzing tool EQUALINK-Viewer.

### Direct download and evaluation via EQUALINK-

Viewer You may also use

the SFTP client that is an integrated part of the EQUALINK Viewer. To do this, enter the IP address and the desired time window.

The EQUALINK viewer will automatically connect to the corresponding EQUALINK web manager and collect the corresponding files.

If wanted the EQUALINK viewer can be instructed to automatically query all registered EQUALINK web manager when the software starts..

### Note:

The BACS viewer software is a powerful freeware battery analysis tool.

You can download the software and manuals from our download area at [www.generex.de](http://www.generex.de).

## Pause Equalization on schedule

For this configuration step, you need the following menu:

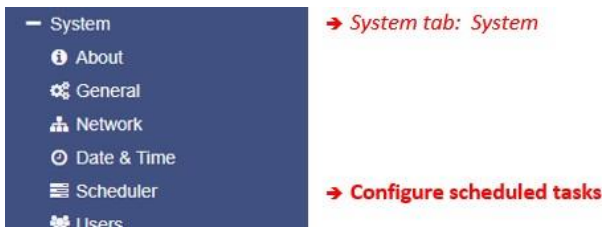

This hidden function is a little bit difficult to explain without basic information about the production process of a battery – please read the following information carefully, it will explain you why this function is very powerful and how set up the most effective configuration that fits to your Batteries ...

Depending on the manufacturer and production process, AGM Batteries require a few charge / discharge cycles to achieve the optimum performance for a standby mode of a UPS. The number of charges / discharge cycles you need to form up your Batteries is a technical puzzler:

Basically, there are two different production methods for Batteries:

### Formed Batteries

As a post production process, formed Batteries were repeatedly charged and discharged. By doing so, the battery chemistry itself will perform a so-called recombination. Caused by the entropy during the charge / discharge cycle, the recombination of the battery chemistry will stabilize the internal resistance of the entire Battery. As a side effect, the Battery's capacity will be maximized.

### Unformed Batteries

These Batteries are produced, packed and sold directly without any post production service. The entire forming process is a part of the final installation on site. The forming process will be performed by the customer during first months of usage - as an example, while running battery stress tests or by random power failures. In the end, these Batteries will also reach full capacity as well as a stabilized internal resistance, but it will take much longer than Batteries that are formed before installation on site.

### OK, but why does unformed Batteries exist?

There is no legal standard that dictates forming - accordingly, it is a service of battery manufacturers and is a quality feature of recently produced Batteries. As a consequence, it is up to the manufacturer how he wants to produce and sell his Batteries:

While some manufacturer only supplies formed Batteries as a quality standard, other manufacturer design two different product lines or produce as cheap as possible.

### **Note**

From a technical point of view, no differences can be observed between the formed and unformed batteries during commissioning - all accumulators that have been assembled to a battery system have to perform such a formation process. The difference is that already pre-formed accumulators can finish this process much faster. Please note, the "formation is finished" can only be seen when evaluating the battery data collected by BACS.

### In principle, EQUALINK eliminates generally harmful voltage fluctuations.

As a result, formed Batteries are spared and can be used over a very long time - sometimes even beyond the manufacturer's specifications about the design life of a battery. However, if Batteries are unformed at start-up, balancing or equalizing, especially in the early days, could slow down the formation process enormously, because the Batteries need these voltage fluctuations.

Determining the optimal time from to hand over the equalization of your EQUALINK system completely, depends, among other things, on the basic operating mode:

### *Scenarios with a cyclic usage*

In the case of cycling applications, formation takes place automatically as there is generally a regular charge / discharge cycle. This means EQUALINK can run immediately and your Batteries will reach their maximum capacity very quickly.

### *Scenarios with a stand-by usage*

In case of standby applications, the situation differs:

Because there is no cyclic discharge, the formation is carried out by natural voltage fluctuations of the UPS. As a consequence, a system that mostly eliminates voltage fluctuations slows down the entire formation process.

## How to use „Pause Equalization“

As you can see, only Chuck Norris has an automatic battery forming process because his roundhouse kick will teach the Batteries what they want to do... In all other cases it is technically not possible because the Batteries can vary enormously depending on batch, grade, manufacturer, chemical composition, storage time after production, storage location, etc. It can actually happen that two Batteries from the same manufacturer need completely different time windows until they reach the formed state - New EQUALINK-controlled UPS systems must be observed individually.

Pause Equalization is thus a kind of "pause function" to facilitate the structured formation or reformation of Batteries. To use this function, open the scheduler and select the job Pause Equalizing:

The screenshot shows the 'Add/Edit Scheduler Task' form with the following fields and annotations:

- Job:** A dropdown menu with 'Pause Equalizing' selected. Annotation: → Select the job "Pause Equalization"
- Parameter:** A section containing 'Hours' with a text input field containing '2'. Annotation: → Toggle the time in hours the equalization process shall pause
- Timing:** A section containing 'Start' (date/time: 09/03/2019 02:50 PM), 'Repeat' (dropdown: One Time), and 'Triggers' (text: At 02:50 PM on 09/03/2019 - one time). Annotation: → Set up the job timing
- Buttons:** 'Save' and 'Cancel' buttons. Annotation: → Save changes / discard changes

## Setting up Hours and job timing

How many hours you want to pause equalizing is difficult to answer - EQUALINK can facilitate and accompany the formation process in many ways. Here are 3 examples how to configure the EQUALINK function pause equalizing:

### *Method 1: As easy as possible*

Pause Equalizing for 5 days and repeat the job:

In this case, choose 120 hours and advise the CS141 to repeat once in a week:

The EQUALINK Webmanager will pause equalizing for 120 hours or 5 days. The UPS is thus given the chance to advance the battery formation 5 days a week. Then the EQUALINK Webmanager will enable Equalizing for 2 days and generate comparable data. After an overall period of 7 days, the job will be re-run ... The EQUALINK Web Manager Monitoring will always inform you if something with the Batteries is not working as expected, even if Equalizing is temporarily disabled or pausing.

*Use a second job to get status information about the forming process:*

On initial start, the EQUALINK Webmanagers integrated monitoring system starts collecting all required battery data for a detailed forming status evaluation. Just add a scheduled mail and the EQUALINK Webmanager will send your regular status reports including necessary log files. You do not need daily reports, getting a statusmail once a month should be enough to decide if the forming process is finished. If there is an additional problem occurs:

EQUALINK will inform you immediately....

*During data evaluation, what are you looking for?*

As an example, if you start with 40 unformed Batteries, you will notice that each battery will show individual charge/discharge voltages. This is not an issue, it is natural for both, pre-formed and unformed Batteries. With each discharge / charge cycle, the voltage curves of all Batteries approach each other until they are only about 1V apart. If this can be seen, Batteries are in sync and the forming process is largely completed. You may quit and delete the scheduled job "Pause Equalizing" and EQUALINK begins its work.

With this method, you can evaluate the battery data once a month and are informed about the current state of health of the Batteries. As soon as the battery data reaches formation parameters and indicates that the formation has been completed successfully, the Pause Equalizing job can be adjusted or removed accordingly.

The screenshot shows the 'Add/Edit Scheduler Task' form with the following fields and annotations:

- Job:** A dropdown menu with 'Email' selected.
- Parameter:** A section containing 'Receiver' (text: techniker@tardis.de), 'Text' (text: Job Pause Equalizing läuft aus...), and three checked checkboxes: 'Use text as subject', 'Eventlog', 'Datalog', and 'Bacsllog'.



### Method 2 – during running – faster but time-consuming

You can also instruct the EQUALINK web manager to take control step by step.

If you choose running this way, equalizing is configured to pause each day for a specific time window. The advantage is that your UPS system is not on its own for the first few weeks. EQUALINK has an eye on it and equalizing is most of the week enabled.

This method allows to plan special charge/discharge cycles without EQUALINK equalizing provides and speed up the forming process. As an example, if your Batteries have a discharge/charge cycle of about 6 hours, you can plan a “not-equalized time window of 6 hours” daily, weekly – you can customize this time window to fit your conditions.

In this example, the job Pause Equalizing will stop the equalizing process from 6:00pm Uhr to 11:00pm.

This will provide a unique time window to run a custom discharge / charge cycle and log the voltage behavior of the Batteries. This method could be very interesting if you change some Batteries and mix some new with old Batteries. Equalizing will save your existing, already formed Batteries and your new Batteries have the chance to form up with all other Batteries.

Timing	
Start	<input type="text" value="06:00 PM"/>
Repeat	<input type="text" value="Daily"/>
Triggers	At 06:00 PM - every day

In this example, we will use a periodic message reporting - if you know that equalizing pauses from 6:00 pm to 11:00 pm, you could create a “formation report” and get the according log files by mail:

Timing	
Start	<input type="text" value="23:15 PM"/>
Repeat	<input type="text" value="Weekly"/>
Triggers	<input type="checkbox" value="Sun"/> <input checked="" type="checkbox" value="Mon"/> <input type="checkbox" value="Tue"/> <input checked="" type="checkbox" value="Wed"/> <input type="checkbox" value="Thu"/> <input checked="" type="checkbox" value="Fri"/> <input type="checkbox" value="Sat"/>
Triggers	At 11:15 PM - every Monday, Wednesday, Friday

In this case, set the je-mail job timing to Weekly and instruct the EQUALINK WEBMANAGER to generate a status mail with the current battery data at 23:15 on Mondays, Wednesdays and Fridays.

As a consequence of a scheduled hour-by-hour formation of Batteries, the entire formation process will take some more time:

Technically, the internal battery chemistry is calmed by eliminating the necessary voltage fluctuations associated with equalization - this will slow down the forming process.

On the other hand, evaluating of data is easier because you can directly compare how the Batteries behave. This will allow you to determine very precisely when there will be no improvement in the voltage values and fully activate the equalization with pinpoint accuracy. As a side effect, you may train to spot strange measuring data.

### Method 3 – Completely scheduled with unique single jobs

If you choose to climb this way, you need some experiences about using Batteries and their behavior when equalize them. In general, the sense of scheduled tasks is to plan jobs and execute them automatically when the time has come to trigger a function. You may choose between cyclic jobs like sending mails with log files or single jobs like a small text message to your RCCMD client to remember yourself a single event is pending.

However, the advantage of this method is, that you can design and configure a general road map to form the Batteries. As an example, it may look like this job list:

- Enable Equalizing for 2 days
- Send an email with log files for data evaluation
- Pause Equalizing for 7 days
- Send an email for data evaluation
- Enable Equalisation for 3 days
- Pause Equalizing for 5 days
- Send a mail with log files for data evaluation
- Pause Equalizing the next 7 days for some hours
- Send a mail with log files for data evaluation
- [...]

This will allow you to create a normalized 6-month battery forming procedure. To abort this scheduled task list because the forming process is finished earlier than expected, just delete this job list.

#### Note:

Forming new battery systems is an individual matter that largely bases on experience. In general, you can say:

Unformed high-quality batteries reach the final operating state faster than unformed less-quality batteries. But it is also possible that pre-formed low-quality batteries may surprise you very much.

Please keep in mind, each battery system is a unique installation that needs an individual point of view.

## Tutorial: EQUALINK deactivated by System

BACS - BIT-2A - UPS-B4																							
Warning: Equalizing deactivated by System																							
Status: Charging																							
String 1 Pos						String 1 Neg						String 2 Pos				String 2 Neg							
No.	Volt. [V]	Temp. [°C]	Ri. [mΩ]	Equalize	Status	No.	Volt. [V]	Temp. [°C]	Ri. [mΩ]	Equalize	Status	No.	Volt. [V]	Temp. [°C]	Ri. [mΩ]	Equalize	Status	No.	Volt. [V]	Temp. [°C]	Ri. [mΩ]	Equalize	Status
1	13.63	24.5	10.96	█	●	21	13.28	27.4	9.20	█	●	41	13.63	25.0	11.21	█	●	61	13.61	26.5	9.76	█	●
2	13.63	25.0	11.70	█	●	22	13.49	27.0	11.39	█	●	42	13.63	23.6	10.39	█	●	62	13.61	26.5	10.31	█	●
3	13.63	24.5	11.39	█	●	23	13.64	25.4	6.05	█	●	43	13.63	25.5	12.01	█	●	63	13.61	26.9	12.11	█	●
4	13.63	24.3	5.70	█	●	24	13.41	25.5	11.46	█	●	44	13.63	25.5	11.19	█	●	64	13.61	25.1	12.04	█	●

With its management functions, EQUALINK actively intervenes in the control process and thus guarantees the optimal charging conditions for each individual battery within the corresponding battery string.

The equalizing level is active for 3 of 4 battery strings. EQUALINK manages each single Batteries individually and adjusted them perfectly to the target voltage. However, for the 4th battery string called "String 1 Neg", EQUALINK displays that the equalizing functions was disabled for some reason.

### Why does EQUALINK disable balancing?

EQUALINK regularly checks whether there is an improvement in the voltage - by doing so, balancing (equalizing) makes sense to the EQUALINK WEBMANAGER, and he will continue with balancing. With some operating conditions, however, it can always happen that EQUALINK would be able to manage the charging current individual to each battery in the battery string, but not without permanent 100% balancing (equalization) and only without any measurable improvements.

In addition to the classic that a battery simply becomes stubborn for literally inexplicable and incomprehensible reasons, there are usually 3 scenarios in which EQUALINK can conclude that equalizing is theoretically possible, but practically examining the Batteries should be:

#### 1. New and old Batteries or Batteries from different manufacturers were mixed

Since EQUALINK adjusts the charging currents individually to the needs of the battery through balancing, a special feature of EQUALINK is that individual Batteries can in principle be exchanged as you wish. If you decide to use another manufacturer, the performance data and battery type can be similar, but the internal battery chemistry differs depending on the grade and mixing ratio or how redox reaction runs during the charging process, etc. Finally, this can lead into big differences between the stock Batteries that simply cannot be balanced over a long period of time – EQUALINK will assume that exact this single battery will never fit to the desired battery string.

#### 2. Damaged Batteries and wiring problems

While a hidden battery damage can appear again and again as an unpredictable factor, with this warning message you should take another look at the Batteries and the cabling, especially after maintenance work. Even if the system itself could run without error notification in its existing configuration, the values collected indicate that something is fundamentally wrong, because at least one module is always running on 100%.

#### 3. Old Batteries

With ongoing aging, Batteries will take over a very individual voltage, charging and capacity behavior and drift apart - in this case, a core task of EQUALINK is to intervene in the charging

cycle and thus create an individually optimized charging environment. As a consequence, the age of the Batteries also increases the intensity with which balancing has to be carried out.

When the Batteries reach the calculated design life, it may become noticeable that EQUALINK has run its balancing up to 100% for some Batteries within a battery string, but without any significant improvements. Although everything is set correctly, EQUALINK will report this information as "Equalizing deactivated by system" and pauses the equalizing accordingly.

String 1 Neg						
No.	Volt. [V]	Temp. [°C]	Ri. [mΩ]	Equalize	Status	
21	13.28	27.4	9.20	█	●	
22	13.49	27.0	11.39	█	●	
23	13.64	25.4	6.05	█	●	
24	13.41	25.5	11.46	█	●	
25	14.10	26.7	11.58	█	●	
26	13.42	25.5	10.76	█	●	
27	13.46	26.0	10.82	█	●	
28	13.42	25.5	10.49	█	●	
29	14.01	26.0	12.26	█	●	
30	14.14	25.5	12.26	█	●	
31	13.40	26.0	11.86	█	●	
32	13.50	25.5	5.83	█	●	
33	13.42	26.5	10.77	█	●	
34	13.43	25.5	12.21	█	●	
35	13.97	25.0	11.25	█	●	
36	13.38	24.7	12.30	█	●	
37	14.00	26.1	11.77	█	●	
38	14.08	25.8	11.68	█	●	
39	13.63	25.5	11.84	█	●	
40	13.39	25.0	10.76	█	●	
Σ Voltage 272.58 V						
13.63 [V] Target Voltage						
-1 [A] Current -0.27 [KW] Real Power						

## Trouble Shooting List

This table shows an event overview and generally recommended actions for helping with maintenance work.

EVENT Name	Event description	Explanation	Recommended reaction
EQUALINK started	Battery monitoring started	EQUALINK System has started and is now managing Batteries	For your information.
EQUALINK Discharging Phase	Battery discharging	EQUALINK System noted that a discharge has started	Check Charger output status and Battery Breaker
EQUALINK ChargingPhase	Battery charging	EQUALINK System is back to normal from a previous discharge.	For your information. Watch if Batteries charge correctly.
<b>EQUALINK SystemAlarm</b>	<b>Module communication is lost and the system is in Alarm mode! React immediately!</b>	<b>EQUALINK system is not functional at this status and needs attention</b>	<b>Intervention required: Check communication cable and addressing</b>
EQUALINK SystemAlarm off	Module communication restored	EQUALINK System communication problems cleared	For your information
EQUALINK VoltageHigh Alarm	EQUALINK Voltage High Alarm	EQUALINK System detected one or more Batteries with voltage out of the configured alarm threshold.	Check battery health and charger
EQUALINK VoltageHigh Alarm off	EQUALINK Voltage High Alarm reset	EQUALINK System High Alarm cleared	For your information.
EQUALINK VoltageLow Alarm	EQUALINK Voltage Low Alarm	EQUALINK System detected one or more Batteries with voltage out of the configured alarm threshold	Check battery health and charger
EQUALINK VoltageLow Alarm off	EQUALINK Voltage Low Alarm reset	EQUALINK System Low Alarm cleared	For your information
<b>EQUALINK Temperature High Alarm</b>	<b>EQUALINK Temperature High Alarm</b>	<b>EQUALINK System detected one or more Batteries with temperature out of the configured alarm threshold</b>	<b>Intervention required: Check charger and environmental conditions and watch if temperature increases or comes back to normal. Check if balancing is active and if ampere rating of battery is correctly configured. If both are correct, check battery health to avoid a thermal runaway.</b>
EQUALINK Temperature High Alarm off	EQUALINK Temperature High Alarm reset	EQUALINK System High Alarm cleared - No action	For your information.
EQUALINK Temperature Low Alarm	EQUALINK Temperature Low Alarm	Temperature of one or more modules are beyond the configured alarm threshold.	Check environmental conditions
EQUALINK Temperature Low Alarm off	EQUALINK Temperature Low Alarm reset	EQUALINK System Low Alarm cleared - No action	For your information.
EQUALINK ResistorHigh Alarm	EQUALINK Resistor High Alarm	Resistance/Impedance of one or more modules are beyond the configured alarm threshold.	Check battery health and voltage level
EQUALINK ResistorHigh Alarm off	EQUALINK Resistor High Alarm reset	EQUALINK System High Alarm cleared.	For your information.
EQUALINK ResistorLow Alarm	EQUALINK Resistor Low Alarm	Resistance/Impedance of one or more modules are beyond the configured alarm threshold	Check battery health and voltage level
EQUALINK ResistorLow Alarm off	EQUALINK Resistor Low Alarm reset	EQUALINK System Low Alarm cleared - No action	For your information.
EQUALINK Voltage Diff High Warning	Voltage difference between single Batteries/cells to high	Battery Voltage difference within one or more battery strings are beyond the configured threshold.	check battery health
EQUALINK Voltage Diff High Warning off	Voltage difference between single Batteries/cells reset	Battery Voltage difference within one or more battery strings are back to normal	For your information
<b>EQUALINK Battery Breaker open Alarm</b>	<b>Battery breaker/fuse open, no battery protection active!</b>	<b>Battery breaker or Battery fuse has been opened.</b>	<b>Intervention required: Check battery breaker/fuse status immediately in order to prevent loss of load in case of a power outage.</b>
EQUALINK Battery Breaker open Alarm off	Battery breaker/fuse closed	Battery breaker/fuse is normal again, Batteries should again pick up charge - no action	For your information, it is recommended to check the battery breakers and fuses
EQUALINK EqualizingError Alarm	Equalisation error	EQUALINK Equalisation Failure automatically stops all balancing functions	Reboot/Coldboot the system and wait for clearance. If the problem cannot be solved by the EQUALINK itself after some hours, call EQUALINK support.
EQUALINK EqualizingError Alarm off	Equalisation error reset	EQUALINK Equalisation Failure cleared	For your information.

EQUALINK VoltageHigh Warning	EQUALINK Voltage HighWarning	EQUALINK System detected one or more Batteries with voltage out of configuredwarning threshold	1. Check if voltage increases or comes back to normal. 2. Check if balancing is active and ampere rating of battery is correctly configured. If both are correct, check battery health
EQUALINK Voltage High Warning off	EQUALINK Voltage HighWarning reset	EQUALINK System High Warning cleared.	For your information.
EQUALINK VoltageLow Warning	EQUALINK Voltage Low Warning	EQUALINK System detected one or more Batteries with voltage out of configuredwarning threshold.	1. Check if voltage decreases or comes back to normal. 2. Check if balancing is active and ampere rating of battery is correctly configured. If both are correct, check battery health
EQUALINK Voltage Low Warning off	EQUALINK Voltage Low Warning reset	EQUALINK System Low Warning cleared.	For your information.
EQUALINK Temperature High Warning	EQUALINK Temperature HighWarning	EQUALINK System detected one or moreBatteries with temperature out of configured warning threshold.	Check charger and environmental conditions and watch if temperature increases or comes back to normal. Check if balancing is active and ampere rating of battery is correctly configured.
EQUALINK Temperature High Warning off	EQUALINK Temperature HighWarning reset	EQUALINK System High Warning cleared.	For your information.
EQUALINK Temperature Low Warning	EQUALINK Temperature Low Warning	EQUALINK System detected one or moreBatteries with temperature out of configured warning threshold.	1. Check if temperature decreases or comes back to normal. 2. Check charger and battery breaker and environmental conditions.
EQUALINK Temperature Low Warning off	EQUALINK Temperature Low Warning reset	EQUALINK System Low Warning cleared.	For your information.
EQUALINK ResistorHigh Warning	EQUALINK Resistor HighWarning	EQUALINK System detected one or moreBatteries with impedance out of configured warning threshold	Check if voltage and temperature is correct. If problem persists, call battery service to check battery health
EQUALINK Resistor High Warning off	EQUALINK Resistor HighWarning reset	EQUALINK System High Warning cleared	For your information.
EQUALINK ResistorLow Warning	EQUALINK Resistor Low Warning	EQUALINK System detected one or moreBatteries with impedance out of configured warning threshold.	Check if voltage and temperature is correct. If problem persists, call battery service to check battery health
EQUALINK Resistor Low Warning off	EQUALINK Resistor Low Warning reset	EQUALINK System Low Warning cleared.	For your information.
EQUALINK GeneralAlarm	General failure/alarm, check website EQUALINK for Alarm details	EQUALINK System detected an Alarm, whattrigger always the general alarm.	Check EQUALINK Webinterface and Logfile forAlarm detail and take a look to the recommended action for it.
EQUALINK GeneralAlarm off	General failure/alarm reset	EQUALINK System general alarm cleared.	For your information.
<b>EQUALINK Thermal Runaway Alarm</b>	<b>Thermal Runaway conditions TRUE</b>	<b>Thermal runaway risk at this string.</b>	<b>Intervention required: Check temperature and voltage and battery health.If battery breaker has been opened, check battery health before closing the breaker</b>
EQUALINK Thermal Runaway Alarm off	Thermal Runaway conditions FALSE - Normal	Thermal runaway alarm cleared	For your information: Evaluate data to find the reason why a thermal runaway alarm happened.
EQUALINK Discharge Counter Alarm	Discharge Counter beyond configured threshold	Configured number of discharges reached.	Check battery health and decide if more cycles can be accepted
EQUALINK Discharge Counter Alarm off	Discharge Counter reset	Discharge Counter has been reset to 0	For your information.
EQUALINK GX_R_AUX 1 Input 1 Alarm Off	GX_R_AUX DigitalInput 1 LOW	Connected dry contact closed/opened, action depends upon connected application.	Action depends on connected application.
EQUALINK GX_R_AUX 1 Input 1 Alarm	GX_R_AUX DigitalInput 1 HIGH	Connected dry contact closed/opened,	action depends upon connected application.
EQUALINK Baseline Impedance Alarm	EQUALINK Baseline ResistorHigh Alarm	Resistance/Impedance of one or more modules are out of the percentual baseline alarm threshold.	Check battery health and voltage level

EQUALINK Baseline Impedance Alarm Off	EQUALINK Baseline ResistorHigh Alarm reset	Alarm / warning cleared.	For your information.
EQUALINK Baseline Impedance Warning	EQUALINK Baseline ResistorHigh Warning	Resistance/Impedance of one or more modules are out of the percentual baseline warning threshold.	check battery health and voltage level
EQUALINK Baseline Impedance Warning Off	EQUALINK Baseline ResistorHigh Warning reset	alarm / warning cleared.	For your information.
EQUALINK String Voltage High Alarm	String voltage too high	String voltage out of configured threshold.	Check Charger and battery health
EQUALINK String Voltage High Alarm Off	String voltage alarm reset	alarm / warning cleared.	For your information.
EQUALINK String Voltage Low Alarm	String voltage too low	String voltage out of configured threshold.	Check Charger and battery health
EQUALINK String Voltage Low Alarm Off	String voltage alarm reset	alarm / warning cleared	For your information.
EQUALINK String Voltage High Warning	String voltage high	String voltage out of configured threshold.	Check Charger and battery health
EQUALINK String Voltage High Warning Off	String voltage warning reset	alarm / warning cleared	For your information.
EQUALINK String Voltage Low Warning	String voltage low	String voltage out of configured threshold.	Check Charger and battery health
EQUALINK String Voltage Low Warning Off	String voltage warning reset	alarm / warning cleared.	For your information.
EQUALINK String Current High Alarm	Positive (Charging) String current too high	String current out of configured alarm threshold. Check Charger and battery health	Check Charger and battery health
EQUALINK String Current High Alarm Off	String current alarm reset	alarm / warning cleared	For your information.
EQUALINK String Current Low Alarm	Negative (Discharging) String current too high	String current out of configured alarm threshold.	Check Charger and battery health
EQUALINK String Current Low Alarm Off	String current alarm reset	alarm / warning cleared	For your information.
EQUALINK String Current High Warning	Positive (Charging) String current high	String current out of configured warning threshold.	Check Charger and battery health
EQUALINK String Current High Warning Off	String current warning reset	alarm / warning cleared - no action	For your information.
EQUALINK String Current Low Warning	Negative (Discharging) String current high	String current out of configured warning threshold.	Check Charger and battery health
EQUALINK String Current Low Warning Off	String current warning reset	alarm / warning cleared.	For your information
EQUALINK Module Revision Alarm	Wrong/Incompatible module revision in EQUALINK bus found	Installation of different EQUALINK modulerevisions or missing module revision information may trigger this alarm.	This is an installation error, different hardware revision modules has been used. Contact EQUALINK support.
EQUALINK Module Revision Alarm Off	Module revision alarm reset	alarm / warning cleared	For your information.

EQUALINK Equalizing deactivated by System	Balancing/Equalization does not take effect for up to 4 days.	If the balancing/equalisation does not show any effect on one or more modules/Batteries, it will be turned off after some time and this warning is triggered	Check battery health
EQUALINK Equalizing deactivated by System Off	Balancing/Equalization restarted - warning reset	alarm / warning cleared	For your information.
EQUALINK String Current Deviation Discharge Alarm	Discharge Current difference between strings too high	EQUALINK has noticed there is a problem when string current measurements deviates compared to other strings during a discharge cycle.	Check Charger and battery string health
EQUALINK String Current Deviation	Discharge Current difference between	alarm / warning cleared - no action	For your information.

Discharge Alarm Off	strings Alarm reset		
EQUALINK String Current Deviation Charge Alarm	Charge Current difference between strings too high	EQUALINK has noticed there is a problem when string current measurements deviates compared to other strings during a charge cycle after discharging.	Check Charger and battery string health
EQUALINK String Current Deviation Charge Alarm Off	Charge Current difference between strings too high reset	alarm / warning cleared	For your information.
EQUALINK String Current Deviation Discharge Warning	Discharge Current difference between strings high	EQUALINK has noticed an unusual high current difference within the battery strings during a discharge cycle.	Check Charger and battery string health
EQUALINK String Current Deviation Discharge Warning Off	Discharge Current difference between strings high reset	alarm / warning cleared	For your information.
EQUALINK String Current Deviation Charge Warning	Charge Current difference between strings high	EQUALINK has noticed an unusual high current difference within the battery strings during a charge cycle.	Check Charger and battery string health

## Copyright and licenses

*The copyright authorization from Exponential Power and other relevant software suppliers must be respected. Exponential Power and their suppliers reserve the rights to the software components. In particular the following are prohibited:*

- *copying and distribution,*
- *modifications and derivations,*
- *decompilation, reverse engineering,*

*Components which fall under GNU General Public License and further Open Source licenses are integrated into the software. An overview of the integrated Open Source components and a copy of the current license can be obtained at [www.Exponentialpower.com](http://www.Exponentialpower.com)*

*Exponential Power will provide the source code for all components of software licensed under the GNU GeneralPublic License and comparable Open Source licenses.*

*For source code requests, please email [te@Exponentialpower.com](mailto:te@Exponentialpower.com)*



## FAQ

### CS141 FAQ-Frequently asked questions

#### *What does system error 500 / 503 mean?*

This error occurs if the web server of the CS141 is not running correctly. If the problem persists after restarting the adapter, the firmware must be updated / re-imported. This is recommended in conjunction with a reset to factory settings

#### *What does error 422 mean?*

This error occurs when trying to adjust the configuration of certain values while using older firmware versions. Updating to the current firmware version shall fix it.

#### *Was bedeutet Fehler 400 / 420/ 522?*

This issue can occur if the firmware has been updated but the browser uses data cached from previous versions. Clearing browser cache should fix it. In rare cases the CS141 needs a cold reboot. Please note, a cold reboot of the CS141 will not affect the UPS.

#### *Der USV status shows „Paused“.*

When CS141 accesses the Alert History of the UPS, the normal connection must be temporarily stopped. By switching to another page inside CS141 menu and pressing F5 to restore the display status (if not done automatically) this should be fixed.

#### *What does issue -1 mean?*

This error occurs if no connection to CS141 is currently possible (CS141 reboots, network lost, etc.), but the user tries to access configuration screen. In this case the browser uses cached data to show the screen without the possibility to enter values. In case of a reboot just give the CS141 a little bit more time.

#### *A little bit awkward, but I forgot my password...*

This happens to everyone now and then. Take a look at the "Rescue system" chapter - this might help you. If not, contact support@Exponential Power.de and we want to find a way to help you.

#### *Why am I logged out when I disable the http tooltips?*

Because the tooltips are related to the http service. Changing some values need to redirect the user after restarting the build-in http service.

#### *The CON\_R\_AUX does not establish a connection!*

This device is not supported by the CS141. You need to use the CON\_R\_AUX4.

#### *I have entries in the log file called "UPSMAN started"*

This entry is generated whenever there was a change in the event configuration: Because the changes are applied immediately, the "UPSMAN service" must be restarted - this will be protocolled.

#### *When accessing the Alert History, I only get an error!*

Maybe this function is not supported by the selected UPS. The fact the CS141 supports your UPS does not mean, your UPS supports all function available at the CS141 for this UPS. This is a little bit complicated to explain: sometimes the UPS should support a command, but ignores it consequently.

#### *I get the error "Backend busy" when I try to log in!*

Please wait a moment and try again with another browser. If the problem persists after 5 minutes, use the / reboot function. Refer the chapter If nothing works ...

#### *Does the CS141 supports SNMP v1 queries?*

Maybe ... yes or no ...

The CS141 has never or will officially support SNMP queries v1.0. On the other hand it does not mean that it can not if you wish to do that. The only issue that might prevent you using the CS141 the way you want: Due to the fact this is officially not supported, there will be no official bug fix if you have problems. Inofficially maybe our developers can do something if they know somethings not working as it should ...

#### *I have questions that are not explained in the manual.*

We always strive to improve our documentation. If you have something that is not or insufficiently explained, please send us a short message to support@Exponential Power.de - We are happy to help you as fast as possible.

**Q: Why the GX\_R\_AUX need to be in it's own strain:**

In principle, you can put the GX\_R\_AUX directly into a EQUALINK bus, it would work too. However, in larger installations with many EQUALINK modules in one string, this could be a problem:

Each EQUALINK module has a galvanic isolation between the control and the communication module. The communication module is supplied with the necessary operating voltage by the EQUALINK bus. However, the GX\_R\_AUX requires more power than the EQUALINK modules, which could cause communication problems inside the complete string. The limit of installed modules before this occurs is fluent and depends heavily on where in the string you placed the GX\_R\_AUX during installation. Therefore, this type of installation is only conditionally recommendable.

**Q I have 34 EQUALINK modules and unfortunately 38 Batteries... Can I just set up 34 Batteries?**

Well... in the end, yes, EQUALINK will monitor and equalize 34 Batteries. The last 4 Batteries will be just loaded. But this is not recommendable. It will lead into problems with the 4 Batteries left:

- No monitoring
- No battery management

The problem is normally not that you can add 4 modules later, the problem is, if EQUALINK is running and working, you may forget to add the last 4 Batteries.

**Appendix:***Hardware Layout CS141*

1. Slide-Switch for network configuration
2. Network Interface
3. COM2 MINIDIN Connector for RS232
4. COM2 Phoenix Connector for RS485
5. Green and Red Status LED
6. AUX Interface
7. PoE Header
8. Debug Adapter
9. Rescue Jumper: Open = Normal Boot, Close = Rescue Boot
10. NAND Flash
11. CPU
12. RAM
13. USB Interface
14. COM1
15. Slot Interface
16. Power Supply
17. DIP Switch
18. Fuse

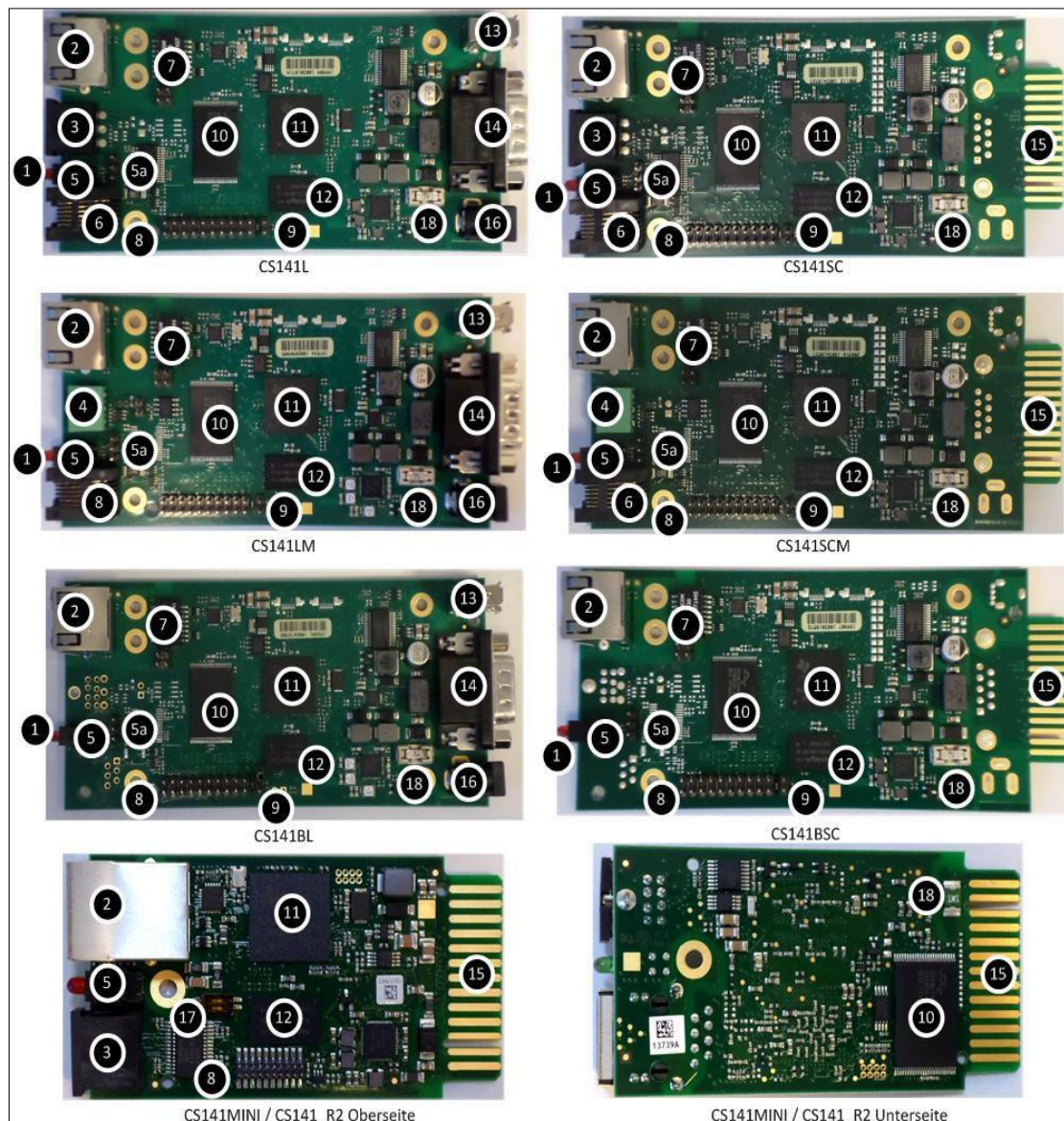

## Interface Description

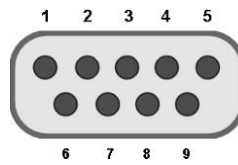

External D-SUB 9-polig male

Pin1:	DCD	Pin6:	DSR
Pin2:	RxD	Pin7:	RTS
Pin3:	TxD	Pin8:	CTS
Pin4:	DTR	Pin9:	RI
Pin5:	GND		

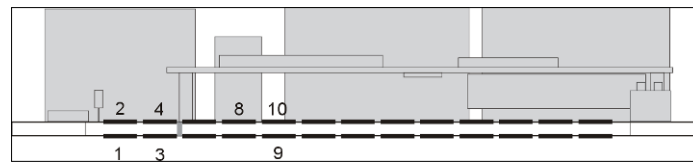

Slot version: Circuit board connection

Pin	Signal name	Level	Function
1	GND		Power Ground
2	8 – 34V DC		Power Input
3	COM1 TXD	V24	COM1 Transmit Data
4	COM1 RXD	V24	COM1 Receive Data
5	SW_GPIO_1 1) 2)	3,3V TTL	CS141DMINI: Functionality of DIP-Switch 1
6	SW_GPIO_2 1) 2)	3,3V TTL	CS141DMINI: Functionality of DIP-Switch 2
7	POW# Input 1)	3,3V TTL	Enable power supply (active low)
8	Bridged with Pin 10		
9	GND		Signal Ground
10	Bridged with Pin 8		
11	COM1 DTR 1)	V24	COM1 Data Transmit Ready
12	COM1 RI 1)	V24	COM1 Ring Indicator
13	COM3 RXD 1) 2)	5V TTL	COM3 Receive Data
14	COM3 TXD 1) 2)	5V TTL	COM3 Transmit Data
15	COM2 TXD 1) 2)	3,3V TTL	COM2 Transmit Data
16	COM2 RXD 1) 2)	3,3V TTL	COM2 Receive Data
17-26	-		n.c.

1) Connectable with solder bridge (MINI: resistor bridge)

2) Input with Pull-Up

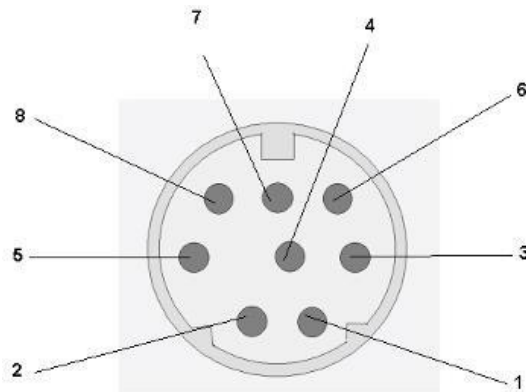
*Pin COM2 Mini-DIN 8 pol*

## Mini DIN 8 socket RS-232:

Pin1: -> DCD  
 Pin2: -> RxD  
 Pin3: -> TxD  
 Pin4: -> DTR  
 Pin5: -> DSR  
 Pin6: -> RTS  
 Pin7: -> CTS  
 Pin8: -> RI  
 shield -> GND

## RS-485 (optional):

Pin1 → GND  
 Pin2 -> RS485/A  
 Pin3 -> RS485/B(-)

AUX-Port (Hardware Revision 1.1 = from Serial numbers 0121-1203, 0122-00198, 0123-00564 onwards) RJ11 6-pol

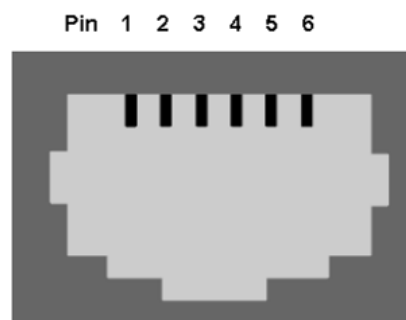

Pin1: -> +3,3V  
 Pin2: ->  
 Pin3: ->  
 Pin4: -> RxD (COM3 Input)  
 Pin5: -> TxD (COM3 Output)  
 Pin6: -> GND

**Modbus addresses**

OEM MODBUS Defaultaddress (for all products/OEMS, not specified further down in this modbus manual)

Address	Type	Function	Name	Description	Length
97	U	3 / 4	OUTPUT_VOLT0	Output Voltage Phase 1 in V	1
98	U	3 / 4	OUTPUT_VOLT1	Output Voltage Phase 2 in V	1
99	U	3 / 4	OUTPUT_VOLT2	Output Voltage Phase 3 in V	1
100	U	3 / 4	OUTPOWER0	Outpower Phase 1 %	1
101	U	3 / 4	OUTPOWER1	Outpower Phase 2 %	1
102	U	3 / 4	OUTPOWER2	Outpower Phase 3 %	1
103	U	3 / 4	BATTCAP	Battery Capacity %	1
104	S	3 / 4	INVOLT0	Input Voltage Phase 1 V	1
105	S	3 / 4	INVOLT1	Input Voltage Phase 2 V	1
106	S	3 / 4	INVOLT2	Input Voltage Phase 3 V	1
107	S	3 / 4	TEMPDEG	Temperature C°	1
108	S	3 / 4	AUTONOMTIME	Autonomy Time minutes	1
109	U	3 / 4	STATUS (e. g. UPS normal = "4", Powerfail = "12", Battery test running = "68", Bypass = "5" )	UPS Status (ASCII HEX) Please note UPSMAN status bytes table below	1
110	S	3 / 4	BATTVOLT	Battery Voltage V	1
111	U	3 / 4	INFREQ0	Input Frequency Hz Phase 1	1
112	U	3 / 4	INFREQ1	Input Frequency Hz Phase 2	1
113	U	3 / 4	INFREQ2	Input Frequency Hz Phase 3	1
114	U	3 / 4	CNT_PF	Powerfail Counter	1
115	U	3 / 4	Alarm Battery Bad	1 = active; 0 = not active	1
116	U	3 / 4	Alarm: On Battery	1 = active; 0 = not active	1
117	U	3 / 4	Alarm: Battery Low	1 = active; 0 = not active	1
118	U	3 / 4	Alarm: Battery Depleted	1 = active; 0 = not active	1
119	U	3 / 4	Alarm: Over temperature	1 = active; 0 = not active	1
120	U	3 / 4	Alarm: Input Bad	1 = active; 0 = not active	1
121	U	3 / 4	Alarm: Output Bad	1 = active; 0 = not active	1
122	U	3 / 4	Alarm: Output Overload	1 = active; 0 = not active	1
123	U	3 / 4	Alarm: On Bypass	1 = active; 0 = not active	1
124	U	3 / 4	Alarm: Bypass Bad	1 = active; 0 = not active	1
125	U	3 / 4	Alarm: Output Off as requested.	1 = active; 0 = not active	1
126	U	3 / 4	Alarm: UPS Off as requested.	1 = active; 0 = not active	1
127	U	3 / 4	Alarm: Charger Failed	1 = active; 0 = not active	1

128	U	3 / 4	Alarm: UPS Output Off	1 = active; 0 = not active	1
129	U	3 / 4	Alarm: UPS System Off	1 = active; 0 = not active	1
130	U	3 / 4	Alarm: Fan Failure	1 = active; 0 = not active	1
131	U	3 / 4	Alarm: fuse failure	1 = active; 0 = not active	1
132	U	3 / 4	Alarm: general fault	1 = active; 0 = not active	1
133	U	3 / 4	Alarm: diagnose test failed	1 = active; 0 = not active	1
134	U	3 / 4	Alarm: communication lost	1 = active; 0 = not active	1
135	U	3 / 4	Alarm: awaiting power	1 = active; 0 = not active	1
136	U	3 / 4	Alarm: shutdown pending	1 = active; 0 = not active	1
137	U	3 / 4	Alarm: shutdown imminent	1 = active; 0 = not active	1
138	U	3 / 4	Alarm: test in progress	1 = active; 0 = not active	1
139	U	3 / 4	AUX Port 1	1 = active (high), 0 = not active (low)	1
140	U	3 / 4	AUX Port 2	1 = active (high), 0 = not active (low)	1
141	U	3 / 4	AUX Port 3	1 = active (high), 0 = not active (low)	1
142	U	3 / 4	AUX Port 4	1 = active (high), 0 = not active (low)	1
143	U	3 / 4	Sensormanager/SMTCOM sensor 1	Analog value	1
144	U	3 / 4	Sensormanager/SMTHCOM sensor 2	Analog value	1
145	U	3 / 4	Sensormanager sensor 3	Analog value	1
146	U	3 / 4	Sensormanager sensor 4	Analog value	1
147	U	3 / 4	Sensormanager sensor 5	Analog value	1
148	U	3 / 4	Sensormanager sensor 6	Analog value	1
149	U	3 / 4	Sensormanager sensor 7	Analog value	1
150	U	3 / 4	Sensormanager sensor 8	Analog value	1

## Section OEM: ABB/NEWAVE UPS Type Concept Power

Address	Type	Function	Name	Description	Length
100	U	3 / 4	OUTPOWER0	Outpower Phase 1 %	1
101	U	3 / 4	OUTPOWER1	Outpower Phase 2 %	1
102	U	3 / 4	OUTPOWER2	Outpower Phase 3 %	1
103	U	3 / 4	BATTCAP	Battery Capacity %	1
104	S	3 / 4	INVOLT0	Input Voltage Phase 1 V	1
105	S	3 / 4	INVOLT1	Input Voltage Phase 2 V	1
106	S	3 / 4	INVOLT2	Input Voltage Phase 3 V	1
107	S	3 / 4	TEMPDEG	Temperature C°	1
108	S	3 / 4	AUTONOMTIME	Autonomy Time minutes	1
109	U	3 / 4	STATUS (e. g. UPS normal = "4", Powerfail = "12", Battery test running = "68", Bypass = "5" )	UPS Status (ASCII HEX) Please note UPSMAN status bytes table below	1
110	S	3 / 4	BATTVOLT	Battery Voltage V	1
111	U	3 / 4	INFREQ0	Input Frequency Hz Phase 1	1
112	U	3 / 4	INFREQ1	Input Frequency Hz Phase 2	1
113	U	3 / 4	INFREQ2	Input Frequency Hz Phase 3	1
114	U	3 / 4	CNT_PF	Powerfail Counter	1
115	U	3 / 4	Alarm Battery Bad	1 = active; 0 = not active	1
116	U	3 / 4	Alarm: On Battery	1 = active; 0 = not active	1
117	U	3 / 4	Alarm: Battery Low	1 = active; 0 = not active	1
118	U	3 / 4	Alarm: Battery Depleted	1 = active; 0 = not active	1
119	U	3 / 4	Alarm: Over temperature	1 = active; 0 = not active	1
120	U	3 / 4	Alarm: Input Bad	1 = active; 0 = not active	1
121	U	3 / 4	Alarm: Output Bad	1 = active; 0 = not active	1
122	U	3 / 4	Alarm: Output Overload	1 = active; 0 = not active	1
123	U	3 / 4	Alarm: On Bypass	1 = active; 0 = not active	1
124	U	3 / 4	Alarm: Bypass Bad	1 = active; 0 = not active	1
125	U	3 / 4	Alarm: Output Off as requested.	1 = active; 0 = not active	1
126	U	3 / 4	Alarm: UPS Off as requested.	1 = active; 0 = not active	1
127	U	3 / 4	Alarm: Charger Failed	1 = active; 0 = not active	1
128	U	3 / 4	Alarm: UPS Output Off	1 = active; 0 = not active	1
129	U	3 / 4	Alarm: UPS System Off	1 = active; 0 = not active	1
130	U	3 / 4	Alarm: Fan Failure	1 = active; 0 = not active	1
131	U	3 / 4	Alarm: fuse failure	1 = active; 0 = not active	1
132	U	3 / 4	Alarm: general fault	1 = active; 0 = not active	1



Address	Type	Function	Name	Description	Length
133	U	3 / 4	Alarm: diagnose test failed	1 = active; 0 = not active	1
134	U	3 / 4	Alarm: communication lost	1 = active; 0 = not active	1
135	U	3 / 4	Alarm: awaiting power	1 = active; 0 = not active	1
136	U	3 / 4	Alarm: shutdown pending	1 = active; 0 = not active	1
137	U	3 / 4	Alarm: shutdown imminent	1 = active; 0 = not active	1
138	U	3 / 4	Alarm: test in progress	1 = active; 0 = not active	1
139	U	3 / 4	Manual Bypass Switch Closed	0 = open 1 = closed	1
140	U	3 / 4	OUTPUT_VOLT0	Outputvoltage Phase 1	1
141	U	3 / 4	OUTPUT_VOLT1	Outputvoltage Phase 2	1
142	U	3 / 4	OUTPUT_VOLT2	Outputvoltage Phase 3	1
143	U	3 / 4	OutputCurrent Phase A * 10	Output Current Phase 1 in Ampere devided by 10	1
144	U	3 / 4	OutputCurrent Phase B * 10	Output Current Phase 1 in Ampere devided by 10	1
145	U	3 / 4	OutputCurrent Phase C * 10	Output Current Phase 1 in Ampere devided by10	1
146	U	3 / 4	xid3017 Bits 0-15	Statusbit, for details please contact NEWAVE	1
147	U	3 / 4	xid3017 Bits 16-31	Statusbit, for details please contact ABB/NEWAVE	1
148	U	3 / 4	xid645 Bits 0-15	Alarmbit, for details please contact ABB/NEWAVE	1
149	U	3 / 4	xid645 Bits 16-31	Alarmbit, for details please contact ABB/NEWAVE	1
150	U	3 / 4	xid645 Bits 32-47	Alarmbit, for details please contact ABB/NEWAVE	1
151	U	3 / 4	xid645 Bits 48-63	Alarmbit, for details please contact ABB/NEWAVE	1
152	U	3 / 4	Sensormanager/SMTCOM sensor 1	Analog value	1
153	U	3 / 4	Sensormanager/SMTHCOM sensor 2	Analog value	1
154	U	3 / 4	Sensormanager sensor 3	Analog value	1
155	U	3 / 4	Sensormanager sensor 4	Analog value	1
156	U	3 / 4	Sensormanager sensor 5	Analog value	1
157	U	3 / 4	Sensormanager sensor 6	Analog value	1
158	U	3 / 4	Sensormanager sensor 7	Analog value	1
159	U	3 / 4	Sensormanager sensor 8	Analog value	1
160	U	3 / 4	TrueOutputPower Phase A in KW	True Output Power Current Phase 1 in Kilowatt	1
161	U	3 / 4	TrueOutputPower Phase A in KW	True Output Power Current Phase 1 in Kilowatt	1
162	U	3 / 4	TrueOutputPower Phase A in KW	True Output Power Current Phase 1 in	1

Address	Type	Function	Name	Description	Length
Kilowatt					
163	U	3 / 4	AUX Port 1	1 = active (high), 0 = not active (low)	1
164	U	3 / 4	AUX Port 2	1 = active (high), 0 = not active (low)	1
165	U	3 / 4	AUX Port 3	1 = active (high), 0 = not active (low)	1
166	U	3 / 4	AUX Port 4	1 = active (high), 0 = not active (low)	1
167	U	3 / 4	BATTERYCURRENT	Battery Current in Ampere	1
168	U	3 / 4	OUTFREQ0	Output Frequency Phase 1 in Hz	1
169	U	3 / 4	UPSIDMASK&0xFFFF	for details please contact NEWAVE	1
170	U	3 / 4	(UPSIDMASK&0xFFFF0000)>>16	for details please contact NEWAVE	1
171	U	3 / 4	AUXINPFREQ0	Auxiliary Input Frequency Phase 1	1
172	U	3 / 4	AUXINPFREQ1	Auxiliary Input Frequency Phase 2	1
173	U	3 / 4	AUXINPFREQ2	Auxiliary Input Frequency Phase 3	1
174	U	3 / 4	AUXINPVOLT0	Auxiliary Input Voltage Phase 1	1
175	U	3 / 4	AUXINPVOLT1	Auxiliary Input Voltage Phase 2	1
176	U	3 / 4	AUXINPVOLT2	Auxiliary Input Voltage Phase 3	1
177	U	3 / 4	BP_FREQ0	Bypass Frequency	1
178	U	3 / 4	BP_VOLT0	Bypass Voltage Phase 1	1
179	U	3 / 4	BP_VOLT1	Bypass Voltage Phase 1	1
180	U	3 / 4	BP_VOLT2	Bypass Voltage Phase 3	1
181	U	3 / 4	(RAWSTATEB&0x8)!=0x8	Statusbit, for details please contact ABB/NEWAVE	1

## Section OEM: MASTERGUARD

Address	Type	Function	Name	Description	Length
97	U	3 / 4	OUTPUT_VOLT0	Output Voltage Phase 1 in V	1
98	U	3 / 4	OUTPUT_VOLT1	Output Voltage Phase 2 in V	1
99	U	3 / 4	OUTPUT_VOLT2	Output Voltage Phase 3 in V	1
100	U	3 / 4	OUTPOWER0	Outpower Phase 1 %	1
101	U	3 / 4	OUTPOWER1	Outpower Phase 2 %	1
102	U	3 / 4	OUTPOWER2	Outpower Phase 3 %	1
103	U	3 / 4	BATTCAP	Battery Capacity %	1
104	S	3 / 4	INVOLT0	Input Voltage Phase 1 V	1
105	S	3 / 4	INVOLT1	Input Voltage Phase 2 V	1
106	S	3 / 4	INVOLT2	Input Voltage Phase 3 V	1
107	S	3 / 4	TEMPDEG	Temperature C°	1
108	S	3 / 4	AUTONOMTIME	Autonomy Time minutes	1

109	U	3 / 4	STATUS (e. g. UPS normal = "4", Powerfail = "12", Battery test running = "68", Bypass = "5" )	UPS Status (ASCII HEX) Please note UPSMAN status bytes table below	1
110	S	3 / 4	BATTVOLT	Battery Voltage V	1
111	U	3 / 4	INFREQ0	Input Frequency Hz Phase 1	1
112	U	3 / 4	INFREQ1	Input Frequency Hz Phase 2	1
113	U	3 / 4	INFREQ2	Input Frequency Hz Phase 3	1
114	U	3 / 4	CNT_PF	Powerfail Counter	1
115	U	3 / 4	Alarm Battery Bad	1 = active; 0 = not active	1
116	U	3 / 4	Alarm: On Battery	1 = active; 0 = not active	1
117	U	3 / 4	Alarm: Battery Low	1 = active; 0 = not active	1
118	U	3 / 4	Alarm: Battery Depleted	1 = active; 0 = not active	1
119	U	3 / 4	Alarm: Over temperature	1 = active; 0 = not active	1
120	U	3 / 4	Alarm: Input Bad	1 = active; 0 = not active	1
121	U	3 / 4	Alarm: Output Bad	1 = active; 0 = not active	1
122	U	3 / 4	Alarm: Output Overload	1 = active; 0 = not active	1
123	U	3 / 4	Alarm: On Bypass	1 = active; 0 = not active	1
124	U	3 / 4	Alarm: Bypass Bad	1 = active; 0 = not active	1
125	U	3 / 4	Alarm: Output Off as requested.	1 = active; 0 = not active	1
126	U	3 / 4	Alarm: UPS Off as requested.	1 = active; 0 = not active	1
127	U	3 / 4	Alarm: Charger Failed	1 = active; 0 = not active	1
128	U	3 / 4	Alarm: UPS Output Off	1 = active; 0 = not active	1
129	U	3 / 4	Alarm: UPS System Off	1 = active; 0 = not active	1
130	U	3 / 4	Alarm: Fan Failure	1 = active; 0 = not active	1
131	U	3 / 4	Alarm: fuse failure	1 = active; 0 = not active	1
132	U	3 / 4	Alarm: general fault	1 = active; 0 = not active	1
133	U	3 / 4	Alarm: diagnose test failed	1 = active; 0 = not active	1
134	U	3 / 4	Alarm: communication lost	1 = active; 0 = not active	1
135	U	3 / 4	Alarm: awaiting power	1 = active; 0 = not active	1
136	U	3 / 4	Alarm: shutdown pending	1 = active; 0 = not active	1
137	U	3 / 4	Alarm: shutdown imminent	1 = active; 0 = not active	1
138	U	3 / 4	Alarm: test in progress	1 = active; 0 = not active	1
139	U	3 / 4	PXWARN		2
141	U	3 / 4	FAULT CODE 1		1
142	U	3 / 4	FAULT CODE 2		1
143	U	3 / 4	FAULT CODE 3		1
144	U	3 / 4	FAULT CODE 4		1

145	U	3 / 4	BADBATTBLOCK 1	1
146	U	3 / 4	BADBATTBLOCK 1	1
147	U	3 / 4	BADBATTBLOCK 1	1
148	U	3 / 4	BADBATTBLOCK 1	1
149	U	3 / 4	BADBATTBLOCK 1	1
150	U	3 / 4	BADBATTBLOCK 1	1

## Section OEM: RITTAL PMC Extension

Address	Type	Function	Name	Description	Length
<b>Digital Input Status(DI)</b>					
0	bit	2	Bypass working	Status 0: Normal, Status 1: Alert	1
1	bit	2	Bypass Interruption	Status 0: Normal, Status 1: Alert	1
2	bit	2	Rectifier Failure	Status 0: Normal, Status 1: Alert	1
3	bit	2	Inverter Failure	Status 0: Normal, Status 1: Alert	1
4	bit	2	Over Temperature	Status 0: Normal, Status 1: Alert	1
5	bit	2	Over Load	Status 0: Normal, Status 1: Alert	1
6	bit	2	0	Status 0: Normal, Status 1: Alert	1
7	bit	2	Battery Voltage too Low	Status 0: Normal, Status 1: Alert	1
8	bit	2	Fuse broken	Status 0: Normal, Status 1: Alert	1
9	bit	2	Battery discharging	Status 0: Normal, Status 1: Alert	1
10	bit	2	0	Status 0: Floating charge, Status 1: Instant charging	1
11~30	bit	2	For future expansion		1
After 31	bit	2	Venders own definition		1
<b>Analog Measurement point (AI)</b>					
00	word	4	U in R phase input voltage	0.1 Volt	
01	word	4	U in S phase input voltage	0.1 Volt	
02	word	4	U in T phase input voltage	0.1 Volt	
03	word	4	I in R phase input current	0.1A	
04	word	4	I in S phase input current	0.1A	
05	word	4	I in T phase input current	0.1A	
06	word	4	F input frequency	0.1Hz	
07	word	4	U out R phase output voltage	0.1 Volt	
08	word	4	U out S phase output voltage	0.1 Volt	
09	word	4	U out T phase output voltage	0.1 Volt	
10	word	4	I out R phase output current	0.1A	
11	word	4	I out S phase output current	0.1A	

12	word	4	I out T phase output current	0.1A
13	word	4	P out output power	0.1kVA
14	word	4	P out output power	0.1kW
15	word	4	PF output power factor	0.01Cos
16	word	4	U Bypass, R phase voltage	0.1 Volt
17	word	4	U Bypass, S phase voltage	0.1 Volt
18	word	4	U Bypass, T phase voltage	0.1 Volt
19	word	4	F out output frequency	0.1Hz
20	word	4	U Bat battery voltage	0.1 Volt
21	word	4	I charch Bat battery charging/discharging	0.1A
22	word	4	Temp 1 battery temperature	0.1degC
23	word	4	Temp 2 battery temperature	0.1degC
24	word	4	Temp 3 battery temperature	0.1degC
25	word	4	Temp 4 battery temperature	0.1degC
26	word	4	Temp 5 UPS shelf temperature	0.1degC
<b>Digital output (DO) (Function 1 to read data; 5 to control the function)</b>				
0	bit	1 / 5	UPS Turn On	
1	bit	1 / 5	UPS Shut down	
2	bit	1 / 5	Alarm Reset	
3	bit	1 / 5	Battery Instant Charging	
4	bit	1 / 5	Battery Floating Charging	
5~10	bit		For future expansion	
After			Vender self-definition	

Address	Type	Function	Name	Description	Length
100	U	3 / 4	OUTPOWER0	True Output Power Current Phase 1 in Kilowatt	1
101	U	3 / 4	OUTPOWER1	True Output Power Current Phase 2 in Kilowatt	1
102	U	3 / 4	OUTPOWER2	True Output Power Current Phase 3 in Kilowatt	1
103	U	3 / 4	BATTCAP	Battery Capacity in %	1
104	U	3 / 4	INVOLT0	Input Voltage Phase 1	1
105	U	3 / 4	INVOLT1	Input Voltage Phase 2	1
106	U	3 / 4	INVOLT2	Input Voltage Phase 3	1
107	U	3 / 4	TEMPDEG	Temperature in Degree C°	1
108	U	3 / 4	AUTONOMTIME	Autonomy Time in Minutes	1

Address	Type	Function	Name	Description	Length
109	U	3 / 4	STATUS	UPS Status (ASCII HEX)  Please note UPSMAN status bytes table below	1
110	U	3 / 4	BATTVOLT	Battery Voltage	1
111	U	3 / 4	INFREQ0	Input Frequency Phase 1 in Hz	1
112	U	3 / 4	INFREQ1	Input Frequency Phase 2 in Hz	1
113	U	3 / 4	INFREQ2	Input Frequency Phase 3 in Hz	1
114	U	3 / 4	CNT_PF	Powerfail Counter	1
115	U	3 / 4	SNMP Alarm	Alarmbit, for details please contact NEWAVE	1
116	U	3 / 4	SNMP Alarm	Alarmbit, for details please contact NEWAVE	1
117	U	3 / 4	SNMP Alarm	Alarmbit, for details please contact NEWAVE	1
118	U	3 / 4	SNMP Alarm	Alarmbit, for details please contact NEWAVE	1
119	U	3 / 4	SNMP Alarm	Alarmbit, for details please contact NEWAVE	1
120	U	3 / 4	SNMP Alarm	Alarmbit, for details please contact NEWAVE	1
121	U	3 / 4	SNMP Alarm	Alarmbit, for details please contact NEWAVE	1
122	U	3 / 4	SNMP Alarm	Alarmbit, for details please contact NEWAVE	1
123	U	3 / 4	SNMP Alarm	Alarmbit, for details please contact NEWAVE	1
124	U	3 / 4	SNMP Alarm	Alarmbit, for details please contact NEWAVE	1
125	U	3 / 4	SNMP Alarm	Alarmbit, for details please contact NEWAVE	1
126	U	3 / 4	SNMP Alarm	Alarmbit, for details please contact NEWAVE	1
127	U	3 / 4	SNMP Alarm	Alarmbit, for details please contact NEWAVE	1
128	U	3 / 4	SNMP Alarm	Alarmbit, for details please contact NEWAVE	1
129	U	3 / 4	SNMP Alarm	Alarmbit, for details please contact NEWAVE	1
130	U	3 / 4	SNMP Alarm	Alarmbit, for details please contact NEWAVE	1
131	U	3 / 4	SNMP Alarm	Alarmbit, for details please contact NEWAVE	1
132	U	3 / 4	SNMP Alarm	Alarmbit, for details please contact NEWAVE	1
133	U	3 / 4	SNMP Alarm	Alarmbit, for details please contact NEWAVE	1
134	U	3 / 4	SNMP Alarm	Alarmbit, for details please contact NEWAVE	1
135	U	3 / 4	SNMP Alarm	Alarmbit, for details please contact NEWAVE	1
136	U	3 / 4	SNMP Alarm	Alarmbit, for details please contact NEWAVE	1
137	U	3 / 4	SNMP Alarm	Alarmbit, for details please contact NEWAVE	1
138	U	3 / 4	SNMP Alarm	Alarmbit, for details please contact NEWAVE	1
139	U	3 / 4	Status Bit	Statusbit, for details please contact NEWAVE	1
140	U	3 / 4	OUTPUT_VOLT0	Output Voltage Phase 1	1
141	U	3 / 4	OUTPUT_VOLT1	Output Voltage Phase 2	1
142	U	3 / 4	OUTPUT_VOLT2	Output Voltage Phase 3	1
143	U	3 / 4	OUTPUT_CURR0	Output Current Phase 1 in KW	1

Address	Type	Function	Name	Description	Length
144	U	3 / 4	OUTPUT_CURR1	Output Current Phase 2 in KW	1
145	U	3 / 4	OUTPUT_CURR2	Output Current Phase 3 in KW	1
146	U	3 / 4	Status Bit	Statusbit, for details please contact NEWAVE	1
147	U	3 / 4	Status Bit	Statusbit, for details please contact NEWAVE	1
148	U	3 / 4	Status Bit	Statusbit, for details please contact NEWAVE	1
149	U	3 / 4	Status Bit	Statusbit, for details please contact NEWAVE	1
150	U	3 / 4	Status Bit	Statusbit, for details please contact NEWAVE	1
151	U	3 / 4	Status Bit	Statusbit, for details please contact NEWAVE	1
152	U	3 / 4	TEMP1	SensorManager/SM_T_H_COM Analog Value	1
153	U	3 / 4	TEMP2	SensorManager/SM_T_H_COM Analog Value	1
154	U	3 / 4	TEMP3	SensorManager Analog Value	1
155	U	3 / 4	TEMP4	SensorManager Analog Value	1
156	U	3 / 4	TEMP5	SensorManager Analog Value	1
157	U	3 / 4	TEMP6	SensorManager Analog Value	1
158	U	3 / 4	TEMP7	SensorManager Analog Value	1
159	U	3 / 4	TEMP8	SensorManager Analog Value	1
160	U	3 / 4	LOADKVA0	Load Phase 1 in KW	1
161	U	3 / 4	LOADKVA1	Load Phase 2 in KW	1
162	U	3 / 4	LOADKVA2	Load Phase 3 in KW	1

## Section OEM: Netminder for all LT and MD types

Address	Type	Function	Name	Description	Length
100	U	3/4	INVOLT	Input Voltage	1
101	U	3/4	OUTPUTVOLT	Output Voltage	1
102	U	3/4	BATTVOLT	Battery Voltage	1
103	U	3/4	OUTPUTCURR	Output Current	1
104	U	3/4	LOADPERC	Load (%)	1
105	U	3/4	OUTPUTPOW	Output Power in W	1
106	U	3/4	KVA	KVA	1
107	U	3/4	FREQUENCY	Frequency	1
108	U	3/4	CS141UPSSTAT	CS141 UPS Status	1
109	U	3/4	Alarm: Battery Bad	1 = active; 0 = not active	1
110	U	3/4	Alarm: On Battery	1 = active; 0 = not active	1
111	U	3/4	Alarm: Battery Low	1 = active; 0 = not active	1
112	U	3/4	Alarm: Battery Depleted	1 = active; 0 = not active	1

113	U	3/4	Alarm: Overtemperature	1 = active; 0 = not active	1
114	U	3/4	Alarm: Input Bad	1 = active; 0 = not active	1
115	U	3/4	Alarm: Output Bad	1 = active; 0 = not active	1
116	U	3/4	Alarm: Output Overload	1 = active; 0 = not active	1
117	U	3/4	Alarm: On Bypass	1 = active; 0 = not active	1
118	U	3/4	Alarm: Bypass Bad	1 = active; 0 = not active	1
119	U	3/4	Alarm: Ouput Off As Requested	1 = active; 0 = not active	1
120	U	3/4	Alarm: UPS Off As Requested	1 = active; 0 = not active	1
121	U	3/4	Alarm: Charger Failed	1 = active; 0 = not active	1
122	U	3/4	Alarm: UPS Output Off	1 = active; 0 = not active	1
123	U	3/4	Alarm: UPS System Off	1 = active; 0 = not active	1
124	U	3/4	Alarm: Fan Failure	1 = active; 0 = not active	1
125	U	3/4	Alarm: Fuse Failure	1 = active; 0 = not active	1
126	U	3/4	Alarm: General Fault	1 = active; 0 = not active	1
127	U	3/4	Alarm: Diagnosis Test Failed	1 = active; 0 = not active	1
128	U	3/4	Alarm: Communication Lost	1 = active; 0 = not active	1
129	U	3/4	Alarm: Awaiting Power	1 = active; 0 = not active	1
130	U	3/4	Alarm: Shutdown Pending	1 = active; 0 = not active	1
131	U	3/4	Alarm: Shutdown Imminent	1 = active; 0 = not active	1
132	U	3/4	Alarm: Test In Progress	1 = active ; 0 = not active	1
133	U	3/4	AUX Port 1	1 = active (high) ; 0 = not active (low)	1
134	U	3/4	AUX Port 2	1 = active (high) ; 0 = not active (low)	1
135	U	3/4	AUX Port 3	1 = active (high) ; 0 = not active (low)	1
136	U	3/4	AUX Port 4	1 = active (high) ; 0 = not active (low)	1
137	U	3/4	SensorManager/SMTH_COM, Sensor 1	Analog Value	1
138	U	3/4	SensorManager/SMTH_COM, Sensor 2	Analog Value	1
139	U	3/4	SensorManager/Sensor 3	Analog Value	1
140	U	3/4	SensorManager/Sensor 4	Analog Value	1
141	U	3/4	SensorManager/Sensor 5	Analog Value	1
142	U	3/4	SensorManager/Sensor 6	Analog Value	1
143	U	3/4	SensorManager/Sensor 7	Analog Value	1
144	U	3/4	SensorManager/Sensor 8	Analog Value	1
145	U	3/4	Result of the last Battery Test	Value 3 = Battery Test passed, Value 4 = Battery Test failed	1



Address	Type	Function	Name	Description	Length
11	U	3 / 4	Manufacturer	Manufacturer	1
27	U	3 / 4	Version	Version	1
43	U	3 / 4	Identification	Identification	1
75	U	3 / 4	MODEL	UPS Model	1
107	U	3 / 4	AUTONOMTIME	Autonomy time in minutes	1
108	U	3 / 4	BATTCAP	Battery capacity in percent	1
109	U	3 / 4	OUTFREQ0	Output Frequency	1
110	U	3 / 4	OUTPUTVOLT0	Output Voltage Phase 1	1
111	U	3 / 4	OUTPUTVOLT1	Output Voltage Phase 2	1
112	U	3 / 4	OUTPUTVOLT1	Output Voltage Phase 3	1
113	U	3 / 4	OUTPOWER0	Outpower Phase 1 in %	1
114	U	3 / 4	OUTPOWER1	Outpower Phase 2 in %	1
115	U	3 / 4	OUTPOWER2	Outpower Phase 3 in %	1
116	U	3 / 4	OUTPOWER0	Outpower Phase 1 in VA	1
117	U	3 / 4	OUTPOWER1	Outpower Phase 2 in VA	1
118	U	3 / 4	OUTPOWER2	Outpower Phase 3 in VA	1
119	U	3 / 4	INPUTFREQ0	Input Frequency Phase 1 in Hz	1
120	U	3 / 4	INPUTFREQ1	Input Frequency Phase 2 in Hz	1
121	U	3 / 4	INPUTFREQ2	Input Frequency Phase 3 in Hz	1
122	U	3 / 4	INPUTVOLT0	Input Voltage Phase 1 in V	1
123	U	3 / 4	INPUTVOLT1	Input Voltage Phase 2 in V	1
124	U	3 / 4	INPUTVOLT2	Input Voltage Phase 3 in V	1
125	U	3 / 4	INPUTCURR0	Input Current Phase 1 in A	1
126	U	3 / 4	INPUTCURR1	Input Current Phase 2 in A	1
127	U	3 / 4	INPUTCURR2	Input Current Phase 3 in A	1
128	U	3 / 4	INPUTPOW0	Input Power Phase 1 in W	1
129	U	3 / 4	INPUTPOW1	Input Power Phase 2 in W	1
130	U	3 / 4	INPUTPOW1	Input Power Phase 3 in W	1
131	U	3 / 4	BATTVOLT	Battery Voltage in V	1
132	U	3 / 4	BATTTEMPDEG	Battery Temperature in Degree Celsius	1
133	U	3 / 4	BATTSEC	Seconds on Battery	1
134	U	3 / 4	Battery Condition	Battery Condition	1
135	U	3 / 4	Amount of Input Phases	Amount of Input Phases	1
136	U	3 / 4	Amount of Output Phases	Amount of Output Phases	1
137	U	3 / 4	Results of Battery Test	1:Ok, 2: Active, 3: Canceled, 4: Failed, else: not started yet	1

138	U	3 / 4	Powerfail	Powerfail	1
139	U	3 / 4	System Shutdown	System Shutdown	1
140	U	3 / 4	UPSMAN started	UPSMAN started	1
141	U	3 / 4	UPS Connection lost	UPS connection lost	1
142	U	3 / 4	UPS Battery old	UPS Battery old	1
143	U	3 / 4	Load >80%	Load >80%	1
144	U	3 / 4	Load >90%	Load >90%	1
145	U	3 / 4	Overload	Overload	1
146	U	3 / 4	Overtemperature Condition	Overtemperature Condition	1
147	U	3 / 4	Bypass on	Bypass on	1
148	U	3 / 4	Battery low	Battery low	1
149	U	3 / 4	Batteries are weak	Batteries are weak	1
150	U	3 / 4	General Alarm Condition	General Alarm Condition	1
151	U	3 / 4	Input Bad Condition	Input Bad Condition	1
152	U	3 / 4	Output Bad Condition	Output Bad Condition	1
153	U	3 / 4	Bypass Not Available	Bypass Not Available	1
154	U	3 / 4	Low Battery Shutdown	Low Battery Shutdown	1
155	U	3 / 4	System off	System off	1
156	U	3 / 4	System Shutdown	System Shutdown	1
157	U	3 / 4	Charger Failure	Charger Failure	1
158	U	3 / 4	Manual Restart Required	Manual Restart Required	1
159	U	3 / 4	Output Circuit Breaker Open	Output Circuit Breaker Open	1
160	U	3 / 4	Remote Emergency Power off	Remote Emergency Power off	1
161	U	3 / 4	Shutdown imminent	Shutdown imminent	1

## Section OEM: Netminder for all other types

Address	Type	Function	Name	Description	Length
100	U	3/4	INVOLT	Input Voltage (I1-n)	1
101	U	3/4	INVOLT	Input Voltage (I2-n)	1
102	U	3/4	INVOLT	Input Voltage (I1-I2)	1
103	U	3/4	OUTPUTVOLT	Output Voltage (I1-n)	1
104	U	3/4	OUTPUTVOLT	Output Voltage (I2-n)	1
105	U	3/4	OUTPUTVOLT	Output Voltage /(I1-I2)	1
106	U	3/4	OUTPUTCURR	Output Current (I1-n)	1
107	U	3/4	OUTPUTCURR	Output Current (I2-n)	1
108	U	3/4	OUTPUTWAT	Output Watts (I1-n)	1
109	U	3/4	OUTPUTWAT	Output Watts (I2-n)	1

110	U	3/4	OUTPUTWAT	Output Watts (I1-I2)	1
111	U	3/4	OUTPUTWATTOT	Output watts (total)	1
112	U	3/4	OUTPUTVA	Output VA (I1-n)	1
113	U	3/4	OUTPUTVA	Output VA (I2-n)	1
114	U	3/4	OUTPUTVA	Output VA (I1-I2)	1
115	U	3/4	OUTPUTVATOT	Output VA (total)	1
116	U	3/4	OUTPUTLOAD	Output Load (I1-n)	1
117	U	3/4	OUTPUTLOAD	Output Load (I2-n)	1
118	U	3/4	OUTPUTFREQ	Output Frequency	1
119	U	3/4	BATTVOLT	Battery Voltage	1
120	U	3/4	PERCBATT	Percentage Battery	1
121	U	3/4	DCCHARGECURR	DC Charging Current	1
122	U	3/4	CS141UPSSTAT	CS141 UPS Status	1
123	U	3/4	Alarm: Battery Bad	1 = active; 0 = not active	1
124	U	3/4	Alarm: On Battery	1 = active; 0 = not active	1
125	U	3/4	Alarm: Battery Low	1 = active; 0 = not active	1
126	U	3/4	Alarm: Battery Depleted	1 = active; 0 = not active	1
127	U	3/4	Alarm: Overtemperature	1 = active; 0 = not active	1
128	U	3/4	Alarm: Input Bad	1 = active; 0 = not active	1
129	U	3/4	Alarm: Output Bad	1 = active; 0 = not active	1
130	U	3/4	Alarm: Output Overload	1 = active; 0 = not active	1
131	U	3/4	Alarm: On Bypass	1 = active; 0 = not active	1
132	U	3/4	Alarm: Bypass Bad	1 = active; 0 = not active	1
133	U	3/4	Alarm: Ouput Off As Requested	1 = active; 0 = not active	1
134	U	3/4	Alarm: UPS Off As Requested	1 = active; 0 = not active	1
135	U	3/4	Alarm: Charger Failed	1 = active; 0 = not active	1
136	U	3/4	Alarm: UPS Output Off	1 = active; 0 = not active	1
137	U	3/4	Alarm: UPS System Off	1 = active; 0 = not active	1
138	U	3/4	Alarm: Fan Failure	1 = active; 0 = not active	1
139	U	3/4	Alarm: Fuse Failure	1 = active; 0 = not active	1
140	U	3/4	Alarm: General Fault	1 = active; 0 = not active	1
141	U	3/4	Alarm: Diagnosis Test Failed	1 = active; 0 = not active	1
142	U	3/4	Alarm: Communication Lost	1 = active; 0 = not active	1
143	U	3/4	Alarm: Awaiting Power	1 = active; 0 = not active	1
144	U	3/4	Alarm: Shutdown Pending	1 = active; 0 = not active	1
145	U	3/4	Alarm: Shutdown Imminent	1 = active; 0 = not active	1
146	U	3/4	Alarm: Test In Progress	1 = active; 0 = not active	1
147	U	3/4	AUX Port 1	1 = active (high) ; 0 = not active (low)	1

148	U	3/4	AUX Port 2	1 = active (high) ; 0 = not active (low)	1
149	U	3/4	AUX Port 3	1 = active (high) ; 0 = not active (low)	1
150	U	3/4	AUX Port 4	1 = active (high) ; 0 = not active (low)	1
151	U	3/4	Sensormngr 1 / SMT_COM,	Analog Value	1
152	U	3/4	Sensormngr 2 / SMTH_COM,	Analog Value	1
153	U	3/4	SensorManager/Sensor 3	Analog Value	1
154	U	3/4	SensorManager/Sensor 4	Analog Value	1
155	U	3/4	SensorManager/Sensor 5	Analog Value	1
156	U	3/4	SensorManager/Sensor 6	Analog Value	1
157	U	3/4	SensorManager/Sensor 7	Analog Value	1
158	U	3/4	SensorManager/Sensor 8	Analog Value	1
159	U	3/4	Result of the last Battery Test	Value 3 = Battery Test passd Value 4 = Battery Test failed	1

## Section OEM : AEG Protect 3. M 2.0

Address	Type	Function	Name	Description	Length
100	U	3/4	(SNMPALARMS&0x6102)==0	Normal Operation	1
101	U	3/4	(SNMPALARMS&0x100)>>8	On Bypass	1
102	U	3/4	(SNMPALARMS&0x2)>>1	On Battery	1
103	U	3/4	(SNMPALARMS&0x4000)>>14	UPS System Off	1
104	U	3/4	(SNMPALARMS&0x20000)>>17	General Fault	1
105	U	3/4	(SNMPALARMS&0x80000)>>19	Communication Lost	1
106	U	3/4	(SNMPALARMS&0x20)>>5	Input Bad	1
107	U	3/4	(SNMPALARMS&0x1000)>>12	Charger Failed	1
108	U	3/4	(SNMPALARMS&0x1)	Battery Bad	1
109	U	3/4	(SNMPALARMS&0x40)>>6	Output Bad	1
110	U	3/4	(SNMPALARMS&0x200)>>9	Bypass Bad	1
111	U	3/4	(SNMPALARMS&0x4)>>2	Low Battery	1
				Depleted Battery	
112	U	3/4	(SNMPALARMS&0x8)>>3		1
113	U	3/4	(SNMPALARMS&0x10)>>4	Temperature Bad	1
114	U	3/4	(SNMPALARMS&0x80)>>7	Output Overload	1
115	U	3/4	(SNMPALARMS&0x8000)>>15	Fan Failure	1
116	U	3/4	(SNMPALARMS&0x2000)>>13	UPS Output Off	1
117	U	3/4	AUX1STATE	1 = active (high) ; 0 = not active (low)	1
118	U	3/4	AUX2STATE	1 = active (high) ; 0 = not active (low)	1
119	U	3/4	AUX3STATE	1 = active (high) ; 0 = not active (low)	1

120	U	3/4	AUX4STATE	1 = active (high) ; 0 = not active (low)	1
121	U	3/4	AMBTEMP		1
122	U	3/4	INFREQ0	Input Frequency Hz Phase 1	1
123	U	3/4	INVOLT0	Input Voltage Phase 1 V	1
124	U	3/4	INVOLT1	Input Voltage Phase 2 V	1
125	U	3/4	INVOLT1	Input Voltage Phase 3 V	1
126	U	3/4	INCURR0	Input Current Phase 1 in Ampere	1
127	U	3/4	INCURR1	Input Current Phase 2 in Ampere	1
128	U	3/4	INCURR2	Input Current Phase 3 in Ampere	1
129	U	3/4	EX_BYP_FREQ		1
130	U	3/4	EX_BYP_VOLT0		1
131	U	3/4	EX_BYP_VOLT1		1
132	U	3/4	EX_BYP_VOLT2		1
133	U	3/4	(EX_BATT_VOLTNEG+EX_BATT_VOLTPOS)*10.0		1
134	U	3/4	(EX_BATT_CURRNEG+EX_BATT_CURRPOS)*5.0		1
135	U	3/4	MIN(ftoi(BATTCAP),ftoi(EX_BATT_CAPNEG))		1
136	U	3/4	AUTONOMTIME	Autonomy Time Minutes	1
137	U	3/4	TEMPDEG	Temperature C°	1
138	U	3/4	OUTFREQ0	Output Frequency Hz	1
139	U	3/4	OUTPUT_VOLT0	Output Voltage Phase 1 V	1
140	U	3/4	OUTPUT_VOLT1	Output Voltage Phase 2 V	1
141	U	3/4	OUTPUT_VOLT2	Output Voltage Phase 3 V	1
142	U	3/4	OUTPOWER0	Outpower Phase 1 %	1
143	U	3/4	OUTPOWER1	Outpower Phase 2 %	1
144	U	3/4	OUTPOWER2	Outpower Phase 3 %	1
145	U	3/4	EX_OUT_CURR0		1
146	U	3/4	EX_OUT_CURR1		1
147	U	3/4	EX_OUT_CURR2		1
148	U	3/4	EX_OUT_WATT0		1
149	U	3/4	EX_OUT_WATT1		1
150	U	3/4	EX_OUT_WATT2		1

## Section OEM: AEG Protect 3.31, 5.31, 8.31

Address	Type	Function	Name	Description	Length
100	U	3/4	(FKTSTATUS&0x4102)==0	Normal Operation	1
101	U	3/4	SNMPALARMS&0x100)>>8	On Bypass	1
102	U	3/4	(SNMPALARMS&0x2)>>1	On Battery	1
103	U	3/4	(SNMPALARMS&0x4000)>>14	UPS System Off	1
104	U	3/4	CNT_PF	Powerfail Counter	1
105	U	3/4	(SNMPALARMS&0x20000)>>17	General Fault	1
106	U	3/4	(SNMPALARMS&0x80000)>>19	Communication Lost	1
107	U	3/4	(SNMPALARMS&0x20)>>5	Input Bad	1
108	U	3/4	(SNMPALARMS&0x1000)>>12	Charger Failed	1
109	U	3/4	(SNMPALARMS&0x1)	Battery Bad	1
110	U	3/4	(SNMPALARMS&0x40)>>6	Output Bad	1
111	U	3/4	(SNMPALARMS&0x200)>>9	Bypass Bad	1
112	U	3/4	(SNMPALARMS&0x4)>>2	Low Battery	1
113	U	3/4	(SNMPALARMS&0x8)>>3	Depleted Battery	1
114	U	3/4	(SNMPALARMS&0x10)>>4	Temperature Bad	1
115	U	3/4	(SNMPALARMS&0x80)>>7	Output Overload	1
116	U	3/4	(SNMPALARMS&0x8000)>>15	Fan Failure	1
117	U	3/4	(SNMPALARMS&0x2000)>>13	UPS Output Off	1
118	U	3/4	AUX1STATE	State AUX Port 1 1 = active (high) ; 0 = not active (low)	1
119	U	3/4	AUX2STATE	State AUX Port 2 1 = active (high) ; 0 = not active (low)	1
120	U	3/4	AUX3STATE	State AUX Port 3 1 = active (high) ; 0 = not active (low)	1
121	U	3/4	AUX4STATE	State AUX Port 4 1 = active (high) ; 0 = not active (low)	1
122	U	3/4	INFREQ0*10.0	Input Frequency Hz Phase 1	1
123	U	3/4	INVOLT0	Input Voltage Phase 1 V	1
124	U	3/4	INVOLT1	Input Voltage Phase 2 V	1
125	U	3/4	INVOLT2	Input Voltage Phase 3 V	1
126	U	3/4	BP_FREQ0*10.0	Output Frequency [Hz]	1
127	U	3/4	BP_VOLT0	Bypass Voltage Phase 1 [V]	1
128	U	3/4	BATTVOLT*10.0	Battery Voltage [V] x 10	1
129	U	3/4	SOLABATTC*10.0	Battery Current [A] x 10	1
130	U	3/4	AUTONOMTIME	Autonomy Time in Minutes	1
131	U	3/4	BATTCAP	Battery Capacity	1

132	U	3/4	TEMPDEG*10.0	Temperature [°C] x 10	1
133	U	3/4	OUTFREQ0*10.0	Output Frequency [Hz] x 10	1
134	U	3/4	OUTPUT_VOLT0	Output Voltage Phase 1 [V]	1
135	U	3/4	OUTPOWER0	Outpower Phase 1 [%]	1
136	U	3/4	OUTPUT_CUR0	Output Current Phase 1 [A]	1
137	U	3/4	OUTPUT_POW0	Outpower Phase 1 [W]	1

## Section OEM: AEG Protect 2.33, 3.33, 4.33, 5.33, 8.33, blue

Address	Type	Function	Name	Description	Length
100	U	3/4	(FKTSTATUS&0x4102)==0	Normal Operation	1
101	U	3/4	SNMPALARMS&0x100)>>8	On Bypass	1
102	U	3/4	(SNMPALARMS&0x2)>>1	On Battery	1
103	U	3/4	(SNMPALARMS&0x4000)>>14	UPS System Off	1
104	U	3/4	CNT_PF	Powerfail Counter	1
105	U	3/4	(SNMPALARMS&0x20000)>>17	General Fault	1
106	U	3/4	(SNMPALARMS&0x80000)>>19	Communication Lost	1
107	U	3/4	(SNMPALARMS&0x20)>>5	Input Bad	1
108	U	3/4	(SNMPALARMS&0x1000)>>12	Charger Failed	1
109	U	3/4	(SNMPALARMS&0x1)	Battery Bad	1
110	U	3/4	(SNMPALARMS&0x40)>>6	Output Bad	1
111	U	3/4	(SNMPALARMS&0x200)>>9	Bypass Bad	1
112	U	3/4	(SNMPALARMS&0x4)>>2	Low Battery	1
113	U	3/4	(SNMPALARMS&0x8)>>3	Depleted Battery	1
114	U	3/4	(SNMPALARMS&0x10)>>4	Temperature Bad	1
115	U	3/4	(SNMPALARMS&0x80)>>7	Output Overload	1
116	U	3/4	(SNMPALARMS&0x8000)>>15	Fan Failure	1
117	U	3/4	(SNMPALARMS&0x2000)>>13	UPS Output Off	1
118	U	3/4	AUX1STATE	State AUX Port 1 1 = active (high) ; 0 = not active (low)	1
119	U	3/4	AUX2STATE	State AUX Port 2 1 = active (high) ; 0 = not active (low)	1
120	U	3/4	AUX3STATE	State AUX Port 3 1 = active (high) ; 0 = not active (low)	1
121	U	3/4	AUX4STATE	State AUX Port 4 1 = active (high) ; 0 = not active (low)	1
122	U	3/4	INFREQ0*10.0	Input Frequency Hz Phase 1	1
123	U	3/4	INVOLT0	Input Voltage Phase 1 V	1
124	U	3/4	INVOLT1	Input Voltage Phase 2 V	1

125	U	3/4	INVOLT2	Input Voltage Phase 3 V	1
126	U	3/4	BP_FREQ0*10.0	Output Frequency [Hz]	1
127	U	3/4	BP_VOLT0	Bypass Voltage Phase 1 [V]	1
128	U	3/4	BP_VOLT1	Bypass Voltage Phase 2 [V]	1
129	U	3/4	BP_VOLT2	Bypass Voltage Phase 3 [V]	1
130	U	3/4	BATTVOLT*10.0	Battery Voltage [V] x 10	1
131	U	3/4	SOLABATTC*10.0	Battery Current [A] x 10	1
132	U	3/4	AUTONOMTIME	Autonomy Time in Minutes	1
133	U	3/4	BATTCAP	Battery Capacity	1
134	U	3/4	TEMPDEG*10.0	Temperature [°C] x 10	1
135	U	3/4	OUTFREQ0*10.0	Output Frequency [Hz] x 10	1
136	U	3/4	OUTPUT_VOLT0	Output Voltage Phase 1 [V]	1
137	U	3/4	OUTPOWER0	Outpower Phase 1 [%]	1
138	U	3/4	OUTPUT_CUR0	Output Current Phase 1 [A]	1
139	U	3/4	OUTPUT_POW0	Outpower Phase 1 [W]	1
140	U	3/4	OUTPUT_VOLT1	Output Voltage Phase 2 [V]	1
141	U	3/4	OUTPOWER1	Outpower Phase 2 [%]	1
142	U	3/4	OUTPUT_CUR1	Output Current Phase 2 [A]	1
143	U	3/4	OUTPUT_POW1	Outpower Phase 2 [W]	1
144	U	3/4	OUTPUT_VOLT2	Output Voltage Phase 3 [V]	1
145	U	3/4	OUTPOWER2	Outpower Phase 3 [%]	1
146	U	3/4	OUTPUT_CUR2	Output Current Phase 3 [A]	1
147	U	3/4	OUTPUT_POW2	Outpower Phase 3 [W]	1

## Section OEM: POWERTRONIX

Adress	Name	MIZAR ALCOR	QUASAR	SUPERNOVAE
100	Outpower Phase 1 %	x	x	x
101	Outpower Phase 2 %	x	x	x
102	Outpower Phase 3 %	x	x	x
103	Battery Capacity %	x	x	x
104	Input Voltage Phase 1 V	x	x	x
105	Input Voltage Phase 2 V	x	x	x
106	Input Voltage Phase 3 V	x	x	x
107	Temperature °C	not supported	x	x
108	Autonomy Time minutes	x	x	x
109	UPS Status (ASCII Hex)	x	x	x
110	Battery Voltage V	x	x	x



111	Input Frequency Phase 1 Hz	not supported	x	not supported
112	Input Frequency Phase 2 Hz	not supported	x	not supported
113	Input Frequency Phase 3 Hz	not supported	x	not supported
114	Powerfail Counter	x	x	x
115	Alarm: Battery Bad	x	x	x
116	Alarm: On Battery	x	x	x
117	Alarm: Battery Low	not supported	not supported	x
118	Alarm: Battery Depleted	x	not supported	x
119	Alarm: Overtemperature	x	not supported	x
120	Alarm: Input Bad	x	x	x
121	Alarm: Output Bad	not supported	x	not supported
122	Alarm: Output Overload	x	x	x
123	Alarm: On Bypass	x	x	x
124	Alarm: Bypass Bad	x	x	x
125	Alarm: Output Off As Requested	x	x	x
126	Alarm: UPS Off As Requested	x	x	x
127	Alarm: Charger Failed		x	x
128	Alarm: UPS Output Off	x	x	x
129	Alarm: UPS Sytem Off	not supported	x	not supported
130	Alarm: Fan Failure	x	not supported	x
131	Alarm: Fuse Failure	not supported	not supported	not supported
132	Alarm: General Fault	x	x	x
133	Alarm: Diagnose Test Failed	not supported	not supported	not supported
134	Alarm: Communication Lost	x	x	x
135	Alarm: Awaiting Power	not supported	not supported	not supported
136	Alarm: Shutdown Pending	not supported	not supported	not supported
137	Alarm: Shutdown Imminent	not supported	not supported	not supported
138	Alarm: Test In Progress	x	not supported	not supported
139	AUX Port 1	x	x	x
140	AUX Port 2	x	x	x
141	AUX Port 3	x	x	x
142	AUX Port 4	x	x	x

## Section OEM: Socomec UPS

Address	Type	Function	Name	Description	Length
97	U	3 / 4	OUTPUT_VOLT0	Output Voltage Phase 1 in V	1
98	U	3 / 4	OUTPUT_VOLT1	Output Voltage Phase 2 in V	1

Address	Type	Function	Name	Description	Length
99	U	3 / 4	OUTPUT_VOLT2	Output Voltage Phase 3 in V	1
100	U	3 / 4	OUTPOWER0	Outpower Phase 1 %	1
101	U	3 / 4	OUTPOWER1	Outpower Phase 2 %	1
102	U	3 / 4	OUTPOWER2	Outpower Phase 3 %	1
103	U	3 / 4	BATTCAP	Battery Capacity %	1
104	S	3 / 4	INVOLT0	Input Voltage Phase 1 V	1
105	S	3 / 4	INVOLT1	Input Voltage Phase 2 V	1
106	S	3 / 4	INVOLT2	Input Voltage Phase 3 V	1
107	S	3 / 4	TEMPDEG	Temperature C°	1
108	S	3 / 4	AUTONOMTIME	Autonomy Time minutes	1
109	U	3 / 4	STATUS	UPS Status (ASCII HEX) Please note UPSMAN status bytes table below (e. g. UPS normal = "4", Powerfail = "12", Battery test running = "68", Bypass = "5" )	1
110	S	3 / 4	BATTVOLT	Battery Voltage V	1
111	U	3 / 4	INFREQ0	Input Frequency Hz Phase 1	1
112	U	3 / 4	INFREQ1	Input Frequency Hz Phase 2	1
113	U	3 / 4	INFREQ2	Input Frequency Hz Phase 3	1
114	U	3 / 4	CNT_PF	Powerfail Counter	1
115	U	3 / 4	Alarm Battery Bad	1 = active; 0 = not active	1
116	U	3 / 4	Alarm: On Battery	1 = active; 0 = not active	1
117	U	3 / 4	Alarm: Battery Low	1 = active; 0 = not active	1
118	U	3 / 4	Alarm: Battery Depleted	1 = active; 0 = not active	1
119	U	3 / 4	Alarm: Over temperature	1 = active; 0 = not active	1
120	U	3 / 4	Alarm: Input Bad	1 = active; 0 = not active	1
121	U	3 / 4	Alarm: Output Bad	1 = active; 0 = not active	1
122	U	3 / 4	Alarm: Output Overload	1 = active; 0 = not active	1
123	U	3 / 4	Alarm: On Bypass	1 = active; 0 = not active	1
124	U	3 / 4	Alarm: Bypass Bad	1 = active; 0 = not active	1
125	U	3 / 4	Alarm: Output Off as requested.	1 = active; 0 = not active	1
126	U	3 / 4	Alarm: UPS Off as requested.	1 = active; 0 = not active	1
127	U	3 / 4	Alarm: Charger Failed	1 = active; 0 = not active	1
128	U	3 / 4	Alarm: UPS Output Off	1 = active; 0 = not active	1
129	U	3 / 4	Alarm: UPS System Off	1 = active; 0 = not active	1
130	U	3 / 4	Alarm: Fan Failure	1 = active; 0 = not active	1
131	U	3 / 4	Alarm: fuse failure	1 = active; 0 = not active	1
132	U	3 / 4	Alarm: general fault	1 = active; 0 = not active	1
133	U	3 / 4	Alarm: diagnose test failed	1 = active; 0 = not active	1

Address	Type	Function	Name	Description	Length
134	U	3 / 4	Alarm: communication lost	1 = active; 0 = not active	1
135	U	3 / 4	Alarm: awaiting power	1 = active; 0 = not active	1
136	U	3 / 4	Alarm: shutdown pending	1 = active; 0 = not active	1
137	U	3 / 4	Alarm: shutdown imminent	1 = active; 0 = not active	1
138	U	3 / 4	Alarm: test in progress	1 = active; 0 = not active	1
139	U	3 / 4	AUX Port 1	1 = active (high), 0 = not active (low)	1
140	U	3 / 4	AUX Port 2	1 = active (high), 0 = not active (low)	1
141	U	3 / 4	AUX Port 3	1 = active (high), 0 = not active (low)	1
142	U	3 / 4	AUX Port 4	1 = active (high), 0 = not active (low)	1
143	U	3 / 4	Sensormanager/SMTCOM sensor 1	Analog value	1
144	U	3 / 4	Sensormanager/SMTHCOM sensor 2	Analog value	1
145	U	3 / 4	Sensormanager sensor 3	Analog value	1
146	U	3 / 4	Sensormanager sensor 4	Analog value	1
147	U	3 / 4	Sensormanager sensor 5	Analog value	1
148	U	3 / 4	Sensormanager sensor 6	Analog value	1
149	U	3 / 4	Sensormanager sensor 7	Analog value	1
150	U	3 / 4	Sensormanager sensor 8	Analog value	1
151	U	3 / 4	INCURR0	Input Current Phase 1	1
152	U	3 / 4	INCURR1	Input Current Phase 2	1
153	U	3 / 4	INCURR2	Input Current Phase 3	1
154	U	3 / 4	OUTFREQ0	Output Frequency Phase 1	1
155	U	3 / 4	EX_OUT_CURR0	External Output Current Phase 1	1
156	U	3 / 4	EX_OUT_CURR1	External Output Current Phase 2	1
157	U	3 / 4	EX_OUT_CURR2	External Output Current Phase 3	1

## Section MHD Modular / Multimatic Modular / AEG Protect 1. Modular, ENIGMA

Address	Type	Function	Name	Description	Length
100	U	3 / 4	OUTPOWER0	Outpower Phase 1 %	1
101	U	3 / 4	OUTPOWER1	Outpower Phase 2 %	1
102	U	3 / 4	OUTPOWER2	Outpower Phase 3 %	1
103	U	3 / 4	BATTCAP	Battery Capacity %	1
104	S	3 / 4	INVOLT0	Input Voltage Phase 1 V	1
105	S	3 / 4	INVOLT1	Input Voltage Phase 2 V	1
106	S	3 / 4	INVOLT2	Input Voltage Phase 3 V	1
107	S	3 / 4	TEMPDEG	Temperature C°	1
108	S	3 / 4	AUTONOMTIME	Autonomy Time minutes	1
109	U	3 / 4	STATUS (e. g. UPS normal = "4", Powerfail = "12", Battery test running = "68", Bypass = "5")	UPS Status (ASCII HEX), please note UPSMAN status bytes table below	1

Address	Type	Function	Name	Description	Length
110	U	3 / 4	BATTVOLT	Battery Voltage V	1
111	U	3 / 4	INFREQ0	Input Frequency Hz Phase 1	1
112	U	3 / 4	INFREQ1	Input Frequency Hz Phase 2	1
113	U	3 / 4	INFREQ2	Input Frequency Hz Phase 3	1
114	U	3 / 4	CNT_PF	Powerfail Counter	1
115	U	3 / 4	(SNMPALARMS&0x1)	Alarm Battery Bad	1
116	U	3 / 4	(SNMPALARMS&0x2)>>1	Alarm: On Battery	1
117	U	3 / 4	(SNMPALARMS&0x4)>>2	Alarm: Battery Low	1
118	U	3 / 4	(SNMPALARMS&0x8)>>3	Alarm: Battery Depleted	1
119	U	3 / 4	(SNMPALARMS&0x10)>>4	Alarm: Over temperature	1
120	U	3 / 4	(SNMPALARMS&0x20)>>5	Alarm: Input Bad	1
121	U	3 / 4	(SNMPALARMS&0x40)>>6	Alarm: Output Bad	1
122	U	3 / 4	(SNMPALARMS&0x80)>>7	Alarm: Output Overload	1
123	U	3 / 4	(SNMPALARMS&0x100)>>8	Alarm: On Bypass	1
124	U	3 / 4	(SNMPALARMS&0x200)>>9	Alarm: Bypass Bad	1
125	U	3 / 4	(SNMPALARMS&0x400)>>10	Alarm: Output Off as requested.	1
126	U	3 / 4	(SNMPALARMS&0x800)>>11	Alarm: UPS Off as requested.	1
127	U	3 / 4	(SNMPALARMS&0x1000)>>12	Alarm: Charger Failed	1
128	U	3 / 4	(SNMPALARMS&0x2000)>>13	Alarm: UPS Output Off	1
129	U	3 / 4	(SNMPALARMS&0x4000)>>14	Alarm: UPS System Off	1
130	U	3 / 4	(SNMPALARMS&0x8000)>>15	Alarm: Fan Failure	1
131	U	3 / 4	(SNMPALARMS&0x10000)>>1	Alarm: fuse failure	1
132	U	3 / 4	(SNMPALARMS&0x20000)>>1	Alarm: general fault	1
133	U	3 / 4	(SNMPALARMS&0x40000)>>1	Alarm: diagnose test failed	1
134	U	3 / 4	(SNMPALARMS&0x80000)>>1	Alarm: communication lost	1
135	U	3 / 4	(SNMPALARMS&0x100000)>>	Alarm: awaiting power	1
136	U	3 / 4	(SNMPALARMS&0x200000)>>	Alarm: shutdown pending	1
137	U	3 / 4	(SNMPALARMS&0x400000)>>	Alarm: shutdown imminent	1
138	U	3 / 4	(SNMPALARMS&0x800000)>>	Alarm: test in progress	1
139	U	3 / 4	AUX1STATE	AUX Port 1	1
140	U	3 / 4	AUX2STATE	AUX Port 2	1
141	U	3 / 4	AUX3STATE	AUX Port 3	1
142	U	3 / 4	AUX4STATE	AUX Port 4	1
143	U	3 / 4	TEMP1	Sensormanager/SMTCOM sensor 1	1
144	U	3 / 4	TEMP2	Sensormanager/SMTHCOM sensor 2	1
145	U	3 / 4	TEMP3	Sensormanager sensor 3	1
146	U	3 / 4	TEMP4	Sensormanager sensor 4	1
147	U	3 / 4	TEMP5	Sensormanager sensor 5	1
148	U	3 / 4	TEMP6	Sensormanager sensor 6	1
149	U	3 / 4	TEMP7	Sensormanager sensor 7	1
150	U	3 / 4	TEMP8	Sensormanager sensor 8	1
151	U	3 / 4	AEESerModulePresent(1)	Status data, for details contact Effekta	1
152	U	3 / 4	AEESerModulePresent(2)	Status data, for details contact Effekta	1
153	U	3 / 4	AEESerModulePresent(3)	Status data, for details contact Effekta	1
154	U	3 / 4	AEESerModulePresent(4)	Status data, for details contact Effekta	1
155	U	3 / 4	AEESerModulePresent(5)	Status data, for details contact Effekta	1
156	U	3 / 4	AEESerModulePresent(6)	Status data, for details contact Effekta	1
157	U	3 / 4	AEESerModuleError(1,1)	Status data, for details contact Effekta	1
158	U	3 / 4	AEESerModuleError(1,2)	Status data, for details contact Effekta	1
159	U	3 / 4	AEESerModuleError(1,3)	Status data, for details contact Effekta	1
160	U	3 / 4	AEESerModuleError(1,4)	Status data, for details contact Effekta	1

Address	Type	Function	Name	Description	Length
161	U	3 / 4	AEESerModuleError(2,1)	Status data, for details contact Effekta	1
162	U	3 / 4	AEESerModuleError(2,2)	Status data, for details contact Effekta	1
163	U	3 / 4	AEESerModuleError(2,3)	Status data, for details contact Effekta	1
164	U	3 / 4	AEESerModuleError(2,4)	Status data, for details contact Effekta	1
165	U	3 / 4	AEESerModuleError(3,1)	Status data, for details contact Effekta	1
166	U	3 / 4	AEESerModuleError(3,2)	Status data, for details contact Effekta	1
167	U	3 / 4	AEESerModuleError(3,3)	Status data, for details contact Effekta	1
168	U	3 / 4	AEESerModuleError(3,4)	Status data, for details contact Effekta	1
169	U	3 / 4	AEESerModuleError(4,1)	Status data, for details contact Effekta	1
170	U	3 / 4	AEESerModuleError(4,2)	Status data, for details contact Effekta	1
171	U	3 / 4	AEESerModuleError(4,3)	Status data, for details contact Effekta	1
172	U	3 / 4	AEESerModuleError(4,4)	Status data, for details contact Effekta	1
173	U	3 / 4	AEESerModuleError(5,1)	Status data, for details contact Effekta	1
174	U	3 / 4	AEESerModuleError(5,2)	Status data, for details contact Effekta	1
175	U	3 / 4	AEESerModuleError(5,3)	Status data, for details contact Effekta	1
176	U	3 / 4	AEESerModuleError(5,4)	Status data, for details contact Effekta	1
177	U	3 / 4	AEESerModuleError(6,1)	Status data, for details contact Effekta	1
178	U	3 / 4	AEESerModuleError(6,2)	Status data, for details contact Effekta	1
179	U	3 / 4	AEESerModuleError(6,3)	Status data, for details contact Effekta	1
180	U	3 / 4	AEESerModuleError(6,4)	Status data, for details contact Effekta	1
181	U	3 / 4	AEESerModuleWarning(1)	Status data, for details contact Effekta	1
182	U	3 / 4	AEESerModuleWarning(2)	Status data, for details contact Effekta	1
183	U	3 / 4	AEESerModuleWarning(3)	Status data, for details contact Effekta	1
184	U	3 / 4	AEESerModuleWarning(4)	Status data, for details contact Effekta	1
185	U	3 / 4	AEESerModuleWarning(5)	Status data, for details contact Effekta	1
186	U	3 / 4	AEESerModuleWarning(6)	Status data, for details contact Effekta	1
187	U	3 / 4	AEESerModuleState(1)	Status data, for details contact Effekta	1
188	U	3 / 4	AEESerModuleState(2)	Status data, for details contact Effekta	1
189	U	3 / 4	AEESerModuleState(3)	Status data, for details contact Effekta	1
190	U	3 / 4	AEESerModuleState(4)	Status data, for details contact Effekta	1
191	U	3 / 4	AEESerModuleState(5)	Status data, for details contact Effekta	1
192	U	3 / 4	AEESerModuleState(6)	Status data, for details contact Effekta	1
193	U	3 / 4	AEESerModuleVolt(1)	Status data, for details contact Effekta	1
194	U	3 / 4	AEESerModuleVolt(2)	Status data, for details contact Effekta	1
195	U	3 / 4	AEESerModuleVolt(3)	Status data, for details contact Effekta	1
196	U	3 / 4	AEESerModuleVolt(4)	Status data, for details contact Effekta	1
197	U	3 / 4	AEESerModuleVolt(5)	Status data, for details contact Effekta	1
198	U	3 / 4	AEESerModuleVolt(6)	Status data, for details contact Effekta	1
199	U	3 / 4	AEESerModuleCurr(1)	Status data, for details contact Effekta	1
200	U	3 / 4	AEESerModuleCurr(2)	Status data, for details contact Effekta	1
201	U	3 / 4	AEESerModuleCurr(3)	Status data, for details contact Effekta	1
202	U	3 / 4	AEESerModuleCurr(4)	Status data, for details contact Effekta	1
203	U	3 / 4	AEESerModuleCurr(5)	Status data, for details contact Effekta	1
204	U	3 / 4	AEESerModuleCurr(6)	Status data, for details contact Effekta	1
205	U	3 / 4	seconbat	Time on Battery [sec.]	1
206	U	3 / 4	OUTPUT_VOLT0	Output Voltage [V]	1
207	U	3 / 4	E_OUTPOWER*10.0	Enigma total output power [KW]	1
208	U	3 / 4	E_OUTCPOWER*10.0	Enigma total output compl. power [KVA]	1

Address	Type	Function	Name	Description	Length
1	U	3 / 4	Manufacturer	Manufacturer	1
17	U	3 / 4	Version	Version	1
33	U	3 / 4	Identification	Identification	1
65	U	3 / 4	Model	Model	1
97	U	3 / 4	AUTONOMTIME	Autonomy time in minutes	1
98	U	3 / 4	BATTCAP	Battery capacity in percent	1
99	U	3 / 4	OUTPUT	Output Source 0 Mains, 1 Battery, 2 Bypass	1
100	U	3 / 4	OUTFREQ0	Output Frequency	1
101	U	3 / 4	SOLAWROV0	Outputvoltage Phase 1 in V	1
102	U	3 / 4	SOLAWROV1	Outputvoltage Phase 2 in V	1
103	U	3 / 4	SOLAWROV2	Outputvoltage Phase 3 in V	1
104	U	3 / 4	SOLAWROC0	Output Current Phase 1 in A	1
105	U	3 / 4	SOLAWROC1	Output Current Phase 2 in A	1
106	U	3 / 4	SOLAWROC2	Output Current Phase 3 in A	1
107	U	3 / 4	OUTPOWER0	Outpower Phase 1 %	1
108	U	3 / 4	OUTPOWER1	Outpower Phase 2 %	1
109	U	3 / 4	OUTPOWER2	Outpower Phase 3 %	1
110	U	3 / 4	SOLSETEMPBAD	Temperature bad	1
111	U	3 / 4	SOLSEINPUTBAD	Input bad	1
112	U	3 / 4	SOLSEOVERLOAD	Overload	1
113	U	3 / 4	SOLSEBYPASSFAULT	Bypass fault	1
114	U	3 / 4	SOLSECHARGERFAULT	Charger fault	1
115	U	3 / 4	SOLSEGENERALFAULT	General fault	1
116	U	3 / 4	SOLSESDPENDING	Shutdown pending	1
117	U	3 / 4	SOLSETESTRESULT	Test result	1
118	U	3 / 4	(SNMPALARMS&0x80000)>>19	Communication Lost Alarm	1
119	U	3 / 4	INFREQ0	Input Frequency Phase 1 in Hz	1
120	U	3 / 4	INFREQ1	Input Frequency Phase 2 in Hz	1
121	U	3 / 4	INFREQ2	Input Frequency Phase 3 in Hz	1
122	U	3 / 4	INVOLT0	Input Voltage Phase 1 in V	1
123	U	3 / 4	INVOLT1	Input Voltage Phase 2 in V	1
124	U	3 / 4	INVOLT2	Input Voltage Phase 3 in V	1
125	U	3 / 4	INCURR0	Input Current Phase 1 in A	1
126	U	3 / 4	INCURR1	Input Current Phase 2 in A	1
127	U	3 / 4	INCURR2	Input Current Phase 3 in A	1
128	U	3 / 4	EX_BYP_VOLT0	Bypass Voltage Phase 1 in V	1

129	U	3 / 4	EX_BYP_VOLT1	Bypass Voltage Phase 2 in V	1
130	U	3 / 4	EX_BYP_VOLT2	Bypass Voltage Phase 3 in V	1
131	U	3 / 4	EX_BYP_CURR0	Bypass Current Phase 1 in A	1
132	U	3 / 4	EX_BYP_CURR1	Bypass Current Phase 2 in A	1
133	U	3 / 4	EX_BYP_CURR2	Bypass Current Phase 3 in A	1
134	U	3 / 4	EX_BYP_WATT0	Bypass Power Phase 1 [W]	1
135	U	3 / 4	EX_BYP_WATT1	Bypass Power Phase 2 [W]	1
136	U	3 / 4	EX_BYP_WATT2	Bypass Power Phase 3 [W]	1
137	U	3 / 4	EX_BYP_FREQ0	Bypass Frequency [Hz]	1
138	U	3 / 4	EX_INP_WATT0	Input Power Phase 1 [W]	1
139	U	3 / 4	EX_INP_WATT1	Input Power Phase 2 [W]	1
140	U	3 / 4	EX_INP_WATT2	Input Power Phase 3 [W]	1
141	U	3 / 4	BATTVOLT	Battery Voltage [V]	1
142	U	3 / 4	TEMPDEG	Temperature [°C]	1
143	U	3 / 4	EX_BATT_SECONBATT	Time on Battery [sec.]	1
144	U	3 / 4	EX_BATT_CURRPOS	positive battery current [A]	1
145	U	3 / 4	BATTCONDITION	Flags for battery condition	1
146	U	3 / 4	INPHASES	amount of Phases at Input	1
147	U	3 / 4	OUTPHASES	amount of Phases at Output	1
148	U	3 / 4	SOLABATTC	Battery Current [A]	1

## Section Inform UPS / Pyramid DSP/Online DSP

Address	Type	Function	Name	Description	Length
100	U	3 / 4	OUTPOWER0	Outpower Phase 1 %	1
101	U	3 / 4	OUTPOWER1	Outpower Phase 2 %	1
102	U	3 / 4	OUTPOWER2	Outpower Phase 3 %	1
103	U	3 / 4	BATTCAP	Battery Capacity %	1
104	S	3 / 4	INVOLT0	Input Voltage Phase 1 V	1
105	S	3 / 4	INVOLT1	Input Voltage Phase 2 V	1
106	S	3 / 4	INVOLT2	Input Voltage Phase 3 V	1
107	S	3 / 4	TEMPDEG	Temperature C°	1
108	S	3 / 4	AUTONOMTIME	Autonomy Time minutes	1
109	U	3 / 4	STATUS (e. g. UPS normal = "4", Powerfail = "12", Battery test running = "68", Bypass = "5" )	UPS Status (ASCII HEX) Please note UPSMAN status bytes table below	1
110	S	3 / 4	BATTVOLT	Battery Voltage V	1

111	U	3 / 4	INFREQ0	Input Frequency Hz Phase 1	1
112	U	3 / 4	INFREQ1	Input Frequency Hz Phase 2	1
113	U	3 / 4	INFREQ2	Input Frequency Hz Phase 3	1
114	U	3 / 4	CNT_PF	Powerfail Counter	1
115	U	3 / 4	Alarm Battery Bad	1 = active; 0 = not active	1
116	U	3 / 4	Alarm: On Battery	1 = active; 0 = not active	1
117	U	3 / 4	Alarm: Battery Low	1 = active; 0 = not active	1
118	U	3 / 4	Alarm: Battery Depleted	1 = active; 0 = not active	1
119	U	3 / 4	Alarm: Over temperature	1 = active; 0 = not active	1
120	U	3 / 4	Alarm: Input Bad	1 = active; 0 = not active	1
121	U	3 / 4	Alarm: Output Bad	1 = active; 0 = not active	1
122	U	3 / 4	Alarm: Output Overload	1 = active; 0 = not active	1
123	U	3 / 4	Alarm: On Bypass	1 = active; 0 = not active	1
124	U	3 / 4	Alarm: Bypass Bad	1 = active; 0 = not active	1
125	U	3 / 4	Alarm: Output Off as requested.	1 = active; 0 = not active	1
126	U	3 / 4	Alarm: UPS Off as requested.	1 = active; 0 = not active	1
127	U	3 / 4	Alarm: Charger Failed	1 = active; 0 = not active	1
128	U	3 / 4	Alarm: UPS Output Off	1 = active; 0 = not active	1
129	U	3 / 4	Alarm: UPS System Off	1 = active; 0 = not active	1
130	U	3 / 4	Alarm: Fan Failure	1 = active; 0 = not active	1
131	U	3 / 4	Alarm: fuse failure	1 = active; 0 = not active	1
132	U	3 / 4	Alarm: general fault	1 = active; 0 = not active	1
133	U	3 / 4	Alarm: diagnose test failed	1 = active; 0 = not active	1
134	U	3 / 4	Alarm: communication lost	1 = active; 0 = not active	1
135	U	3 / 4	Alarm: awaiting power	1 = active; 0 = not active	1
136	U	3 / 4	Alarm: shutdown pending	1 = active; 0 = not active	1
137	U	3 / 4	Alarm: shutdown imminent	1 = active; 0 = not active	1
138	U	3 / 4	Alarm: test in progress	1 = active; 0 = not active	1
139	U	3 / 4	AUX Port 1	1 = active (high), 0 = not active (low)	1
140	U	3 / 4	AUX Port 2	1 = active (high), 0 = not active (low)	1
141	U	3 / 4	AUX Port 3	1 = active (high), 0 = not active (low)	1
142	U	3 / 4	AUX Port 4	1 = active (high), 0 = not active (low)	1
143	U	3 / 4	Sensormanager/SMTCOM sensor 1	Analog value	1
144	U	3 / 4	Sensormanager/SMTHCOM sensor 2	Analog value	1
145	U	3 / 4	Sensormanager sensor 3	Analog value	1
146	U	3 / 4	Sensormanager sensor 4	Analog value	1
147	U	3 / 4	Sensormanager sensor 5	Analog value	1



148	U	3 / 4	Sensormanager sensor 6	Analog value	1
149	U	3 / 4	Sensormanager sensor 7	Analog value	1
150	U	3 / 4	Sensormanager sensor 8	Analog value	1
151	U	3 / 4	OUTPUT_VOLT0	Outputvoltage Phase 1	1
152	U	3 / 4	OUTPUT_VOLT1	Outputvoltage Phase 2	1
153	U	3 / 4	OUTPUT_VOLT2	Outputvoltage Phase 3	1
154	U	3 / 4	OUTPUT_CURRENT0	Output Current Phase 1 in Ampere *10	1
155	U	3 / 4	OUTPUT_CURRENT1	Output Current Phase 2 in Ampere *10	1
156	U	3 / 4	OUTPUT_CURRENT2	Output Current Phase 3 in Ampere *10	1

#### Section Transfer Switches (All Transfer Switch vendors, except PILLER, STS TUMEL)

Address	Type	Function	Name	Description	Length
1	U	3 / 4	Sources Asynchronous	Warning, input current difference, switching might not be possible	1
2	U	3 / 4	Static Switch A Failure	Alarm, switching failure	1
3	U	3 / 4	Static Switch B Failure	Alarm, switching failure	1
4	U	3 / 4	On Static Switch A	Supplied from input A	1
5	U	3 / 4	On Static Switch B	Supplied from input B	1
6	U	3 / 4	On Manual Bypass A	Supplied via bypass from input A	1
7	U	3 / 4	On Manual Bypass B	Supplied via bypass from input B	1
8	U	3 / 4	Source A Failure	Alarm, input A failure, problem with voltage	1
9	U	3 / 4	Source B Failure	Alarm, input B failure, problem with voltage	1
10	U	3 / 4	General Fault	General alarm	1
11	U	3 / 4	Redundancy Lost	Redundancy lost,	1
12	U	3 / 4	Output Overload	To much load	1
13	U	3 / 4	Output Failure	Output failure	1

#### Section STS TUMEL Transfer Switch

Address	Type	Function	Name	Description	Length
100	U	3 / 4	INPVOLT_NET_10	Input Voltage S1 Phase 1 [V]	1
101	U	3 / 4	INPVOLT_NET_11	Input Voltage S1 Phase 2 [V]	1
102	U	3 / 4	INPVOLT_NET_12	Input Voltage S1 Phase 3 [V]	1
103	U	3 / 4	INFREQ_NET_1	Input Frequency S1 [Hz]	1
104	U	3 / 4	INPVOLT_NET_20	Input Voltage S2 Phase 1 [V]	1
105	U	3 / 4	INPVOLT_NET_21	Input Voltage S2 Phase 2 [V]	1
106	U	3 / 4	INPVOLT_NET_22	Input Voltage S2 Phase 3 [V]	1

107	U	3 / 4	INFREQ_NET_2	Input Frequency S2 [Hz]	1
108	U	3 / 4	STS_SYNCANGLE	Synchron Angle	1
109	U	3 / 4	STS_SYNDIFF	Synchron Difference	1
110	U	3 / 4	STS_S1BALANCE	S1 Phase Balance	1
111	U	3 / 4	STS_S2BALANCE	S2 Phase Balance	1
112	U	3 / 4	TEMPDEG	Temperature [°C]	1
113	U	3 / 4	OUTPUT_VOLT0	Output Voltage Phase 1 [V]	1
114	U	3 / 4	OUTPUT_VOLT1	Output Voltage Phase 2 [V]	1
115	U	3 / 4	OUTPUT_VOLT1	Output Voltage Phase 3 [V]	1
116	U	3 / 4	EX_OUT_CURR0	Output Current Phase 1 [A]	1
117	U	3 / 4	EX_OUT_CURR1	Output Current Phase 2 [A]	1
118	U	3 / 4	EX_OUT_CURR2	Output Current Phase 3 [A]	1
119	U	3 / 4	OUTPOWER0	Output Power Phase 1 [W]	1
120	U	3 / 4	OUTPOWER1	Output Power Phase 2 [W]	1
121	U	3 / 4	OUTPOWER2	Output Power Phase 3 [W]	1
122	U	3 / 4	STS_ALARMS0	Status Byte (for details contact manufacturer)	1
123	U	3 / 4	STS_ALARMS1	Status Byte (for details contact manufacturer)	1
124	U	3 / 4	STS_ALARMS2	Status Byte (for details contact manufacturer)	1
125	U	3 / 4	STS_ALARMS3	Status Byte (for details contact manufacturer)	1
126	U	3 / 4	STS_ALARMS4	Status Byte (for details contact manufacturer)	1
127	U	3 / 4	STS_STATUS_S1	Status S1 OK (1:yes / 0:no)	1
128	U	3 / 4	STS_STATUS_S2	Status S2 OK (1:yes / 0:no)	1
129	U	3 / 4	STS_Status_S1_Pref	S1 is preferred (1: yes / 0: no)	1
130	U	3 / 4	STS_Status_S2_Pref	S2 is preferred (1: yes / 0: no)	1
131	U	3 / 4	STS_Status_Load_Pef	Load on Preferred Source (1 yes / 0 no)	1
132	U	3 / 4	STS_Status_Trans	Transfer possible (0: yes / 1: no)	1
133	U	3 / 4	STS_Status_GF	General Fault (1: yes / 0: no)	1
134	U	3 / 4	STS_Status_OL	Overload (1: yes / 0: no)	1
135	U	3 / 4	STS_Status_OF	Output Failure (1: yes / 0: no)	1

## Section OEM TRIMOD

Address	Type	Function	Name	Description	Length
100	U	3 / 4	OUTPOWER0	Outpower Phase 1 %	1
101	U	3 / 4	OUTPOWER1	Outpower Phase 2 %	1
102	U	3 / 4	OUTPOWER2	Outpower Phase 3 %	1
103	U	3 / 4	BATTCAP	Battery capacity in percent	1
104	U	3 / 4	INVOLT0	Input Voltage Phase 1 in V	1

105	U	3 / 4	INVOLT1	Input Voltage Phase 2 in V	1
106	U	3 / 4	INVOLT2	Input Voltage Phase 3 in V	1
107	U	3 / 4	TEMPDEG	Temperature C°	1
108	U	3 / 4	AUTONOMTIME	Autonomy Time minutes	1
109	U	3 / 4	STATUS	EXPONENTIAL POWER UPS status	1
110	U	3 / 4	BATTVOLT	Battery Voltage V	1
111	U	3 / 4	INFREQ0	Input Frequency Hz Phase 1	1
112	U	3 / 4	INFREQ1	Input Frequency Hz Phase 2	1
113	U	3 / 4	INFREQ2	Input Frequency Hz Phase 3	1
114	U	3 / 4	CNT_PF	Powerfail Counter	1
115	U	3 / 4	(SNMPALARMS&0x1)	Alarmbit,contact legrand / Meta	1
116	U	3 / 4	(SNMPALARMS&0x2)>>1	Alarmbit,contact legrand / Meta	1
117	U	3 / 4	(SNMPALARMS&0x4)>>2	Alarmbit,contact legrand / Meta	1
118	U	3 / 4	(SNMPALARMS&0x8)>>3	Alarmbit,contact legrand / Meta	1
119	U	3 / 4	(SNMPALARMS&0x10)>>4	Alarmbit,contact legrand / Meta	1
120	U	3 / 4	(stoi(TRIMOD_STATUS)&0x8)	Alarmbit,contact legrand / Meta	1
121	U	3 / 4	(CBSER2ALARM&0x40)>>6	Alarmbit,contact legrand / Meta	1
122	U	3 / 4	(SNMPALARMS&0x80)>>7	Alarmbit,contact legrand / Meta	1
123	U	3 / 4	(SNMPALARMS&0x100)>>8	Alarmbit,contact legrand / Meta	1
124	U	3 / 4	(stoi(TRIMOD_STATUS)&0x8)	Alarmbit,contact legrand / Meta	1
125	U	3 / 4	(SNMPALARMS&0x2000)>>13	Alarmbit,contact legrand / Meta	1
126	U	3 / 4	(SNMPALARMS&0x4000)>>14	Alarmbit,contact legrand / Meta	1
127	U	3 / 4	(SNMPALARMS&0x1000)>>12	Alarmbit,contact legrand / Meta	1
128	U	3 / 4	(SNMPALARMS&0x2000)>>13	Alarmbit,contact legrand / Meta	1
129	U	3 / 4	(SNMPALARMS&0x4000)>>14	Alarmbit,contact legrand / Meta	1
130	U	3 / 4	(SNMPALARMS&0x8000)>>15	Alarmbit,contact legrand / Meta	1
131	U	3 / 4	(SNMPALARMS&0x10000)>>16	Alarmbit,contact legrand / Meta	1
132	U	3 / 4	(SNMPALARMS&0x20000)>>17	Alarmbit,contact legrand / Meta	1
133	U	3 / 4	(stoi(CP_TESTRESULT)==2)	Alarmbit,contact legrand / Meta	1
134	U	3 / 4	(SNMPALARMS&0x80000)>>19	Alarmbit,contact legrand / Meta	1
135	U	3 / 4	(SNMPALARMS&0x100000)>>20	Alarmbit,contact legrand / Meta	1
136	U	3 / 4	(CBSER2ALARM&0x200000)>>2	Alarmbit,contact legrand / Meta	1
137	U	3 / 4	(CBSER2ALARM&0x400000)>>2	Alarmbit,contact legrand / Meta	1
138	U	3 / 4	(SNMPALARMS&0x800000)>>23	Alarmbit,contact legrand / Meta	1
139	U	3 / 4	(stoi(TRIMOD_STATUS)&0x10)	Alarmbit,contact legrand / Meta	1
140	U	3 / 4	OUTPUT_VOLT0	Outputvoltage Phase 1	1
141	U	3 / 4	OUTPUT_VOLT1	Outputvoltage Phase 2	1
142	U	3 / 4	OUTPUT_VOLT2	Outputvoltage Phase 3	1

143	U	3 / 4	TRIMOD_OUTCURR0*10.0	Output Current 1	1
144	U	3 / 4	TRIMOD_OUTCURR1*10.0	Output Current 2	1
145	U	3 / 4	TRIMOD_OUTCURR2*10.0	Output Current 3	1
152	U	3 / 4	TEMP1	Sensorman. sensor 1 / SMTCOM	1
153	U	3 / 4	TEMP2	Sensorman. sensor 2 / SMTHCOM	1
154	U	3 / 4	TEMP3	Sensormanager sensor 3	1
155	U	3 / 4	TEMP4	Sensormanager sensor 4	1
156	U	3 / 4	TEMP5	Sensormanager sensor 5	1
157	U	3 / 4	TEMP6	Sensormanager sensor 6	1
158	U	3 / 4	TEMP7	Sensormanager sensor 7	1
159	U	3 / 4	TEMP8	Sensormanager sensor 8	1
160	U	3 / 4	TRIMOD_OUTACTPWR0/1000.0	Output Phase 1	1
161	U	3 / 4	TRIMOD_OUTACTPWR1/1000.0	Output Phase 2	1
162	U	3 / 4	TRIMOD_OUTACTPWR2/1000.0	Output Phase 3	1
163	U	3 / 4	AUX1STATE	AUX Port 1	1
164	U	3 / 4	AUX2STATE	AUX Port 2	1
165	U	3 / 4	AUX3STATE	AUX Port 3	1
166	U	3 / 4	AUX4STATE	AUX Port 4	1

## Section: EverExceed Inverter

Address	Type	Function	Name	Description	Length
100	U	3 / 4	TEMPDEG	Temperature in Degrees	1
101	U	3 / 4	INFREQ0	Line frequency	1
102	U	3 / 4	INVOLT0	Line voltage	1
103	U	3 / 4	OUTFREQ0	Frequency	1
104	U	3 / 4	OUTPUT_VOLT0	Output voltage	1
105	U	3 / 4	EX_OUT_VA0	Output power	1
106	U	3 / 4	STATUS	EXPONENTIAL POWER UPS status (see below)	1
107	U	3 / 4	EX_EXTSTATUS	Alarm information	1
108	U	3 / 4	STATUS&1	Bypass mode, 1 = on, 0 = off	1
109	U	3 / 4	(STATUS&0x02)>>2	Output active, 1 = on, 0 = off	1
110	U	3 / 4	(STATUS&0x100)>>8	Overload, 1 = on, 0 = off	1
111	U	3 / 4	(STATUS&0x2000)>>13	General alarm, 1 = on, 0 = off	1

UPS Status EverExceed	Hex-Value	Dec-Value	Description
UPS_SB_BYPASS_MODE	0x0001	1	Bypass mode
UPS_SB_OUTPUT_ACT	0x0004	4	Output active
UPS_SB_OUTPUT_HIGH	0x0100	256	Overload
UPS_SB_UPS_FAILED	0x2000	8192	General alarm

Other OEM's : See OEM MODBUS Defaultadress 100 – 146 above

UPSMAN Status Bytes - Standard Device Status Bits

UPS Status	Hex-Value	Dec-Value	Description
UPS_SB_BYPASS_MODE	0x0001	1	power piped thru
UPS_SB_SHUTDOWN	0x0002	2	shutdown ups
UPS_SB_OUTPUT_ACT	0x0004	4	inverter on = UPS OK
UPS_SB_BACKUP_MODE	0x0008	8	battery power
UPS_SB_BATTERY_LOW	0x0010	16	low battery err
UPS_SB_OVER_TEMP	0x0020	32	over temp err
UPS_SB_TEST_ACT	0x0040	64	test in progress
UPS_SB_INPUT_HIGH	0x0080	128	over power err
UPS_SB_OUTPUT_HIGH	0x0100	256	over load err
UPS_SB_INVERTER_FAILURE	0x0200	512	Inverter error
UPS_SB_BATTERY_BAD	0x0400	1024	Battery error
UPS_SB_ECO_MODE	0x0800	2048	eco - bypass
UPS_SB_INVERTER_WARN	0x1000	4096	eco - bypass
UPS_SB_UPS_FAILED	0x2000	8192	prser flag
UPS_SB_COMM_LOST	0x4000	16384	for snmp
UPS_SB_DVG_ALARM	0x8000	32768	SiteManager/SiteMonitor

**Example (decimal):**

STATUS= „5“ means UPS\_SB\_OUTPUT\_ACT (4) + UPS\_SB\_BYPASS\_MODE (1) are active != UPS on Bypass!

STATUS= „12“ means UPS\_SB\_OUTPUT\_ACT (4) + UPS\_SB\_BACKUP\_MODE (8) are active != UPS Powerfail!

STATUS= „28“ means UPS\_SB\_OUTPUT\_ACT (4) + UPS\_SB\_BACKUP\_MODE (8) + UPS\_SB\_BATTERY\_LOW (16) are active != UPS Powerfail and Battery low!

STATUS= „4“ means UPS\_SB\_OUTPUT\_ACT (4) + no other alarms = UPS OK

## **EQUALINK MODBUS Parameter**

### **Standard EQUALINK – Address Description**

Note: the max. number of EQUALINK Modules requestable through MODBUS is 330.

Note: “Type U/S”: this defines whether the answer has an algebraic sign (math. +/-) or not. U means “

Address	Type	Function	Name	Description	Length
<b>Note:</b>					
"Type U/S": this defines whether the answer has an algebraic sign (math. +/-) or not. U means "unsigned". S means "signed", this answer may be positive or negative.					
1000	U	3 / 4	EQUALINK_Alarm	EQUALINK Alarm Flags (see alarmflag definition below) <b>*4</b>	1
1001	U	3 / 4	EQUALINK_ALARM	EQUALINK Alarm Flags (see alarmflag definition below) <b>*5</b>	1
1002	U	3 / 4	EQUALINK_ALARM	EQUALINK Alarm Flags (see alarmflag definition below) <b>*6</b>	1
1003	U	3 / 4	EQUALINK_NUMSTRINGS	Number of EQUALINK Strings	1
1004	U	3/4	EQUALINK_NUMMODULES	Total number of EQUALINK modules	1
<i>This address range describes current and voltage of each single string as configured</i>					
1010	S	3 / 4	STRING_01_CUR	String 1 current in Ampere [A]	1
1011	S	3 / 4	EQUALINK_StrSumVolt	String 1 Overall EQUALINK stringvoltage	1
1012	S	3 / 4	EQUALINK_StrAvgVolt	String 1 Average EQUALINK stringvoltage	1
1013	S	3 / 4	EQUALINK_Str_CurrAC	String 1 EQUALINK string current	1
1014			<RESERVED>	Do not use	
1015	S	3 / 4	STRING_02_CUR	String 2 current in Ampere [A]	1
1016	S	3 / 4	EQUALINK_StrSumVolt	String 2 Overall EQUALINK stringvoltage	1
1017	S	3 / 4	EQUALINK_StrAvgVolt	String 2 Average EQUALINK stringvoltage	1
1018	S	3 / 4	EQUALINK_Str_CurrAC	String 2 EQUALINK string current	1
1019			<RESERVED>	Do not use	
1020	S	3 / 4	STRING_03_CUR	String 3 current in Ampere [A]	1
1021	S	3 / 4	EQUALINK_StrSumVolt	String 3 Overall EQUALINK stringvoltage	1
1022	S	3 / 4	EQUALINK_StrAvgVolt	String3 Average EQUALINK stringvoltage	1
1023	S	3 / 4	EQUALINK_Str_CurrAC	String 3 EQUALINK string current	1

1024			<RESERVED>	Do not use	
------	--	--	------------	------------	--



[...]	[...]	[...]	<i>[...Continue modbus string count until address ...]</i>		[...]
1055	S	3 / 4	STRING_10_CUR	String 10 current in Ampere [A]	1
1056	S	3 / 4	EQUALINK_StrSumVolt	String 10 Overall EQUALINK stringvoltage	1
1057	S	3 / 4	EQUALINK_StrAvgVolt	String 10 Average EQUALINK stringvoltage	1
1058	S	3 / 4	EQUALINK_Str_CurrAC	String 10 EQUALINK string current	1
1059			<RESERVED>	Do not use	
<i>This address range describes the EQUALINK module modbus address range for module 1-330: Each module section contains 5 measuring values. There is no reserved address between the modules!</i>					
1060	S	3 / 4	MODULE_001_TEMP	<b>Module 1</b> Temperature in Celsius [°C] (see Temfjasdfashfklashf) *1	1
1061	S	3 / 4	MODULE_001_VOLT	<b>Module 1</b> Voltage in Volt [V] *2	1
1062	S	3 / 4	MODULE_001_IMPC	<b>Module 1</b> Impedance in milliOhm [mΩ] *3	1
1063	U	3 / 4	MODULE_001_ALARM	<b>Module 1</b> Alarm flags *6	1
1064	S	3 / 4	Module_001_ModBypVoltPc	<b>Module 1</b> Equalizing / Balancing in %	1
1065	S	3 / 4	MODULE_002_TEMP	<b>Module 2</b> Temperature in Celsius [°C] (see Temfjasdfashfklashf) *1	1
1066	S	3 / 4	MODULE_002_VOLT	<b>Module 2</b> Voltage in Volt [V] *2	1
1067	S	3 / 4	MODULE_002_IMPC	<b>Module 2</b> Impedance in milliOhm [mΩ] *3	1
1068	U	3 / 4	MODULE_002_ALARM	<b>Module 2</b> Alarm flags *6	1
1069	S	3 7 4	Module_002_ModBypVoltPc	<b>Module 2</b> Equalizing / Balancing in %	1
1070	S	3 / 4	MODULE_003_TEMP	<b>Module 3</b> Temperature in Celsius [°C] (see Temfjasdfashfklashf) *1	1
1071	S	3 / 4	MODULE_003_VOLT	<b>Module 3</b> Voltage in Volt [V] *2	1
1072	S	3 / 4	MODULE_003_IMPC	<b>Module 3</b> Impedance in milliOhm [mΩ] *3	1
1073	U	3 / 4	MODULE_003_ALARM	<b>Module 3</b> Alarm flags *6	1
1074	S	3 / 4	Module_003_ModBypVoltPc	<b>Module 3</b> Equalizing / Balancing in %	1
[...]	[...]	[...]	<i>[...Continue modbus EQUALINK module count until address ...]</i>		[...]

2705	S	3 / 4	MODULE_330_TEMP	<b>Module 330</b> Temperature in Celsius [°C] (see Temfjasdfashfklashf) *1	1
2706	S	3 / 4	MODULE_330_VOLT	<b>Module 330</b> Voltage in Volt [V] *2	1
2707	S	3 / 4	MODULE_330_IMPC	<b>Module 330</b> Impedance in milliOhm [mΩ] *3	1
2708	U	3 / 4	MODULE_330_ALARM	<b>Module 330</b> Alarm flags *6	1
2709	S	3 / 4	Module_330_ModByVoltPc	<b>Module 330</b> <DESCRIPTION>	1
<i>The following address range describes single string current and voltage for EQUALINK strings 11-16</i>					
2710	S	3 / 4	STRING_11_CUR	String 11 current in Ampere [A]	1
2711			<RESERVED>	Reserved, do not use	
2712			<RESERVED>	Reserved, do not use	
2713	S	3 / 4	String_11_AC	String 11 voltage	1
2714			<RESERVED>	Reserved, do not use	
2715	S	3 / 4	STRING_12_CUR	String 12 current in Ampere [A]	1
2716			<RESERVED>	Reserved, do not use	
2717			<RESERVED>	Reserved, do not use	
2718	S		String_12_AC	String 12 voltage	1
2719			<RESERVED>	Reserved, do not use	
...	...	...	<i>[...Continue modbus EQUALINK String count until address ...]</i>		...
2735	S	3 / 4	STRING_16_CUR	String 16 current in Ampere [A]	1
2736			<RESERVED>	Reserved, do not use	
2737			<RESERVED>	Reserved, do not use	
2738	S		String_12_AC	String 12 voltage	1
2739			<RESERVED>	Reserved, do not use	
<i>This address range describes the EQUALINK module modbus address range for module 331-512: Each module section contains 5 measuring values. There is no reserved address between the modules!</i>					
2740	S	3 / 4	MODULE_331_TEMP	<b>Module 331</b> Temperature in Celsius [°C] (see Temfjasdfashfklashf) *1	1
2741	S	3 / 4	MODULE_331_VOLT	<b>Module 331</b> Voltage in Volt [V] *2	1

2742	S	3 / 4	MODULE_331_IMPC	<b>Module 331</b> Impedance in milliOhm [mΩ] *3	1	
2743	U	3 / 4	MODULE_331_ALARM	<b>Module 331</b> Alarm flags *6	1	
2744	S	3 / 4	Module_331_ModBypVoltPc	<b>Module 331</b> Equalizing / Balancing in %	1	
2745	S	3 / 4	MODULE_332_TEMP	<b>Module 332</b> Temperature in Celsius [°C] (see Temfjasdfashfklashf) *1	1	
2746	S	3 / 4	MODULE_332_VOLT	<b>Module 332</b> Voltage in Volt [V] *2	1	
2747	S	3 / 4	MODULE_332_IMPC	<b>Module 332</b> Impedance in milliOhm [mΩ] *3	1	
2748	U	3 / 4	MODULE_332_ALARM	<b>Module 332</b> Alarm flags *6	1	
2749	S	3 / 4	Module_332_ModBypVoltPc	<b>Module 332</b> Equalizing / Balancing in %	1	
...	...	...	<i>[...Continue modbus EQUALINK module count until address ...]</i>			...
3645	S	3 / 4	MODULE_512_TEMP	<b>Module 512</b> Temperature in Celsius [°C] (see Temfjasdfashfklashf) *1	1	
3646	S	3 / 4	MODULE_512_VOLT	<b>Module 512</b> Voltage in Volt [V] *2	1	
3647	S	3 / 4	MODULE_512_IMPC	<b>Module 512</b> Impedance in milliOhm [mΩ] *3	1	
3648	U	3 / 4	MODULE_512_ALARM	<b>Module 512</b> Alarm flags *6	1	
3649	S	3 / 4	Module_512_ModBypVoltPc	<b>Module 512</b> Equalizing / Balancing in %	1	
<i>This section describes the GX_R AUX alarm status. Depending on the number of GX_R_AUX you have installed, there are up to 16 possible address numbers.</i>						
3650	S	3 / 4	EQUALINKGXRAuxAlarm(0)	GX_R_AUX 1 Alarm Status 1	1	
3651	S	3 / 4	EQUALINKGXRAuxAlarm(1)	GX_R_AUX 1 Alarm Status 2	1	
3652	S	3 / 4	EQUALINKGXRAuxAlarm(2)	GX_R_AUX 1 Alarm Status 3	1	
3653	S	3 / 4	EQUALINKGXRAuxAlarm(3)	GX_R_AUX 1 Alarm Status 4	1	
3654	S	3 / 4	EQUALINKGXRAuxAlarm(4)	GX_R_AUX 2 Alarm Status 1	1	
3655	S	3 / 4	EQUALINKGXRAuxAlarm(5)	GX_R_AUX 2 Alarm Status 2	1	
3656	S	3 / 4	EQUALINKGXRAuxAlarm(6)	GX_R_AUX 2 Alarm Status 3	1	

3657	S	3 / 4	EQUALINKGXRAuxAlarm(7)	GX_R_AUX 2 Alarm Status 4	1
3658	S	3 / 4	EQUALINKGXRAuxAlarm(8)	GX_R_AUX 3 Alarm Status 1	1
3659	S	3 / 4	EQUALINKGXRAuxAlarm(9)	GX_R_AUX 3 Alarm Status 2	1
3660	S	3 / 4	EQUALINKGXRAuxAlarm(10)	GX_R_AUX 3 Alarm Status 3	1
3661	S	3 / 4	EQUALINKGXRAuxAlarm(11)	GX_R_AUX 3 Alarm Status 4	1
3662	S	3 / 4	EQUALINKGXRAuxAlarm(12)	GX_R_AUX 4 Alarm Status 1	1
3663	S	3 / 4	EQUALINKGXRAuxAlarm(13)	GX_R_AUX 4 Alarm Status 2	1
3664	S	3 / 4	EQUALINKGXRAuxAlarm(14)	GX_R_AUX 4 Alarm Status 3	1
3665	S	3 / 4	EQUALINKGXRAuxAlarm(15)	GX_R_AUX 4 Alarm Status 4	1
This section describes the GX_R_AUX Output status. Depending on the Number of GX_R_AUX you have installed, there are up to 16 possible address numbers.					
3666	S	3 / 4	EQUALINKGXRAuxOutputStatus(0)	GX_R_AUX 1 Output Status 1	1
3667	S	3 / 4	EQUALINKGXRAuxOutputStatus(1)	GX_R_AUX 1 Output Status 2	1
3668	S	3 / 4	EQUALINKGXRAuxOutputStatus(2)	GX_R_AUX 1 Output Status 3	1
3669	S	3 / 4	EQUALINKGXRAuxOutputStatus(3)	GX_R_AUX 1 Output Status 4	1
3670	S	3 / 4	EQUALINKGXRAuxOutputStatus(4)	GX_R_AUX 2 Output Status 1	1
3671	S	3 / 4	EQUALINKGXRAuxOutputStatus(5)	GX_R_AUX 2 Output Status 2	1
3672	S	3 / 4	EQUALINKGXRAuxOutputStatus(6)	GX_R_AUX 2 Output Status 3	1
3673	S	3 / 4	EQUALINKGXRAuxOutputStatus(7)	GX_R_AUX 2 Output Status 4	1
3674	S	3 / 4	EQUALINKGXRAuxOutputStatus(8)	GX_R_AUX 3 Output Status 1	1
3675	S	3 / 4	EQUALINKGXRAuxOutputStatus(9)	GX_R_AUX 3 Output Status 2	1
3676	S	3 / 4	EQUALINKGXRAuxOutputStatus(10)	GX_R_AUX 3 Output Status 3	1
3677	S	3 / 4	EQUALINKGXRAuxOutputStatus(11)	GX_R_AUX 3 Output Status 4	1
3678	S	3 / 4	EQUALINKGXRAuxOutputStatus(12)	GX_R_AUX 4 Output Status 1	1
3679	S	3 / 4	EQUALINKGXRAuxOutputStatus(13)	GX_R_AUX 4 Output Status 2	1
3680	S	3 / 4	EQUALINKGXRAuxOutputStatus(14)	GX_R_AUX 4 Output Status 3	1
3681	S	3 / 4	EQUALINKGXRAuxOutputStatus(15)	GX_R_AUX 4 Output Status 4	1

**Note:** A value of -1 or -9999 means: This value is currently “Not available” (“N/A”).

**\*1 - Temperature value definition:**

**Temperature T in °C**       $T = \frac{X-78}{2}$       **e.g.**     $T = \frac{128-78}{2} = 25$

0xXX → 0 bis 255

0x7F    127 => 24,5°C

0x80    128 => 25°C

0x81    129 => 25,5°C

**\*2 - Voltage value definition:**

**Voltage U in V**              Wert / 1000

e.g. **Voltage U in V** = 12825 / 1000 = 12,825 V

**\*3 - Impedance value definition:**

**Impedance Z in mΩ**        Wert / 100

e.g. **Impedance Z in mΩ** = 4372 / 1000 = 43,72 mΩ

**\*4 – Address 1000 MODBUS/SNMP**              (hexadecimal)              (decimal)

EQUALINK_STATE_NONE	0x0000	0	
EQUALINK_STATE_RUNNING	0x0001	1	
EQUALINK_STATE_CONNECTED	0x0002	2	
EQUALINK_STATE_MODULE_LOST	0x0004	4	
EQUALINK_STATE_DISCHARGING	0x0008	8	
EQUALINK_STATE_CHARGING	0x0010	16	
EQUALINK_STATE_DISCHARGING_STOPPED	0x0020	32	
EQUALINK_STATE_FLOAT_CHARGING	0x0040	64	
EQUALINK_STATE_EQUALISATION	0x0080	128	
EQUALINK_STATE_SYSTEM_FAILURE	0x0100	256	
EQUALINK_STATE_VOLTAGE_OUTOFRANGE	0x0200	512	
EQUALINK_STATE_TEMPERATURE_OUTOFRANGE	0x0400	1024	
EQUALINK_STATE_RESISTOR-OUTOFRANGE		0x0800	2048
EQUALINK_STATE_MODULE-ADDRESSING	0x1000	4096	
EQUALINK_STATE_MODULE-SEARCHING	0x2000	8192	
EQUALINK_STATE_MODULE-INITIALIZING	0x4000	16384	
EQUALINK_STATE_MODULE-POLLING	0x8000	32768	

**\*5 – Address 1001 MODBUS/SNMP** (hexadecimal) (decimal)

EQUALINK_STATE-GENERAL-ALARM	0x0001	1
EQUALINK_STATE-VOLTAGE-DIFF-HIGH	0x0002	2
EQUALINK_STATE-BATTERY-BREAKER-OPEN	0x0004	4
EQUALINK_STATE_THERMAL_RUNAWAY	0x0008	8

**\*6 – Address 1002 Alarm Flags MODBUS/SNMP** (hexadecimal) (decimal)

EQUALINK_ALARM_NONE	0x0000	0
EQUALINK_ALARM_GENERAL_ALARM	0x0001	1

EQUALINK_ALARM_COMMUNICATION_LOST	0x0002	2
CS_ALARM_VOLTAGE_HIGH	0x0004	4

EQUALINK_ALARM_VOLTAGE_LOW	0x0008	8
EQUALINK_ALARM_TEMPERATURE_HIGH	0x0010	16
EQUALINK_ALARM_TEMPERATURE_LOW	0x0020	32
EQUALINK_ALARM_RESISTOR_HIGH	0x0040	64
EQUALINK_ALARM_RESISTOR_LOW	0x0080	128
EQUALINK_ALARM_EQUALISATION_ERR	0x0100	256
EQUALINK_ALARM_VOLTAGE_WARN_HIGH	0x0200	512
EQUALINK_ALARM_VOLTAGE_WARN_LOW	0x0400	1024
EQUALINK_ALARM_TEMPERATURE_WARN_H IGH	0x0800	2048
EQUALINK_ALARM_TEMPERATURE_WARN_L OW	0x1000	4096
EQUALINK_ALARM_RESISTOR_WARN_HIGH	0x2000	8192
EQUALINK_ALARM_RESISTOR_WARN_LOW	0x4000	16384
EQUALINK_ALARM_MODREV_INCOMPATIBL E	0x8000	32768



## RFC 1628 MIB Overview

This is the RFC 1628 MIB overview. At [www.Exponential Power.com](http://www.Exponential Power.com), you can download the MIB file and use it with your SNMP monitoring system.

ups MIB      RFC1628

1.3.6.1.2.1      mib2

1.3.6.1.2.1.33	upsMIB
1.3.6.1.2.1.33.1	upsObjects
1.3.6.1.2.1.33.1.1	upsIdent
1.3.6.1.2.1.33.1.1.1	upsIdentManufacturer
1.3.6.1.2.1.33.1.1.2	upsIdentModel
1.3.6.1.2.1.33.1.1.3	upsIdentUPSSoftwareVersion
1.3.6.1.2.1.33.1.1.4	upsIdentAgentSoftwareVersion
1.3.6.1.2.1.33.1.1.5	upsIdentName
1.3.6.1.2.1.33.1.1.6	upsIdentAttachedDevices
1.3.6.1.2.1.33.1.1.7	upsSerialNumber
1.3.6.1.2.1.33.1.1.8	upsLocation
1.3.6.1.2.1.33.1.1.9	upsSystemContact
1.3.6.1.2.1.33.1.2	upsBattery
1.3.6.1.2.1.33.1.2.1	upsBatteriestatus
1.3.6.1.2.1.33.1.2.2	upsSecondsOnBattery
1.3.6.1.2.1.33.1.2.3	upsEstimatedMinutesRemaining
1.3.6.1.2.1.33.1.2.4	upsEstimatedChargeRemaining
1.3.6.1.2.1.33.1.2.5	upsBatteryVoltage
1.3.6.1.2.1.33.1.2.6	upsBatteryCurrent
1.3.6.1.2.1.33.1.2.7	upsBatteryTemperature
1.3.6.1.2.1.33.1.3	upsInput
1.3.6.1.2.1.33.1.3.1	upsInputLineBads
1.3.6.1.2.1.33.1.3.2	upsInputNumLines
1.3.6.1.2.1.33.1.3.3	upsInputTable
1.3.6.1.2.1.33.1.3.3.1	upsInputEntry
1.3.6.1.2.1.33.1.3.3.1.1	upsInputLineIndex
1.3.6.1.2.1.33.1.3.3.1.2	upsInputFrequency
1.3.6.1.2.1.33.1.3.3.1.3	upsInputVoltage
1.3.6.1.2.1.33.1.3.3.1.4	upsInputCurrent
1.3.6.1.2.1.33.1.3.3.1.5	upsInputTruePower
1.3.6.1.2.1.33.1.4	upsOutput
1.3.6.1.2.1.33.1.4.1	upsOutputSource
1.3.6.1.2.1.33.1.4.2	upsOutputFrequency
1.3.6.1.2.1.33.1.4.3	upsOutputNumLines
1.3.6.1.2.1.33.1.4.4	upsOutputTable
1.3.6.1.2.1.33.1.4.4.1	upsOutputEntry
1.3.6.1.2.1.33.1.4.4.1.1	upsOutputLineIndex
1.3.6.1.2.1.33.1.4.4.1.2	upsOutputVoltage
1.3.6.1.2.1.33.1.4.4.1.3	upsOutputCurrent
1.3.6.1.2.1.33.1.4.4.1.4	upsOutputPower
1.3.6.1.2.1.33.1.4.4.1.5	upsOutputPercentLoad
1.3.6.1.2.1.33.1.5	upsBypass
1.3.6.1.2.1.33.1.5.1	upsBypassFrequency
1.3.6.1.2.1.33.1.5.2	upsBypassNumLines
1.3.6.1.2.1.33.1.5.3	upsBypassTable
1.3.6.1.2.1.33.1.5.3.1	upsBypassEntry
1.3.6.1.2.1.33.1.5.3.1.1	upsBypassLineIndex
1.3.6.1.2.1.33.1.5.3.1.2	upsBypassVoltage
1.3.6.1.2.1.33.1.5.3.1.3	upsBypassCurrent
1.3.6.1.2.1.33.1.5.3.1.4	upsBypassPower
1.3.6.1.2.1.33.1.6	upsAlarm

1.3.6.1.2.1.33.1.6.1	upsAlarmsPresent
1.3.6.1.2.1.33.1.6.2	upsAlarmTable
1.3.6.1.2.1.33.1.6.2.1	upsAlarmEntry
1.3.6.1.2.1.33.1.6.2.1.1	upsAlarmId
1.3.6.1.2.1.33.1.6.2.1.2	upsAlarmDescr
1.3.6.1.2.1.33.1.6.2.1.3	upsAlarmTime
1.3.6.1.2.1.33.1.6.3	upsWellKnownAlarms
1.3.6.1.2.1.33.1.6.3.1	upsAlarmBatteryBad
1.3.6.1.2.1.33.1.6.3.2	upsAlarmOnBattery
1.3.6.1.2.1.33.1.6.3.3	upsAlarmLowBattery
1.3.6.1.2.1.33.1.6.3.4	upsAlarmDepletedBattery
1.3.6.1.2.1.33.1.6.3.5	upsAlarmTempBad
1.3.6.1.2.1.33.1.6.3.6	upsAlarmInputBad
1.3.6.1.2.1.33.1.6.3.7	upsAlarmOutputBad
1.3.6.1.2.1.33.1.6.3.8	upsAlarmOutputOverload
1.3.6.1.2.1.33.1.6.3.9	upsAlarmOnBypass
1.3.6.1.2.1.33.1.6.3.10	upsAlarmBypassBad
1.3.6.1.2.1.33.1.6.3.11	upsAlarmOutputOffAsRequested
1.3.6.1.2.1.33.1.6.3.12	upsAlarmUpsOffAsRequested
1.3.6.1.2.1.33.1.6.3.13	upsAlarmChargerFailed
1.3.6.1.2.1.33.1.6.3.14	upsAlarmUpsOutputOff
1.3.6.1.2.1.33.1.6.3.15	upsAlarmUpsSystemOff
1.3.6.1.2.1.33.1.6.3.16	upsAlarmFanFailure
1.3.6.1.2.1.33.1.6.3.17	upsAlarmFuseFailure
1.3.6.1.2.1.33.1.6.3.18	upsAlarmGeneralFault
1.3.6.1.2.1.33.1.6.3.19	upsAlarmDiagnosticTestFailed
1.3.6.1.2.1.33.1.6.3.20	upsAlarmCommunicationsLost
1.3.6.1.2.1.33.1.6.3.21	upsAlarmAwaitingPower
1.3.6.1.2.1.33.1.6.3.22	upsAlarmShutdownPending
1.3.6.1.2.1.33.1.6.3.23	upsAlarmShutdownImminent
1.3.6.1.2.1.33.1.6.3.24	upsAlarmTestInProgress
1.3.6.1.2.1.33.1.6.3.25	upsAlarmAuxInput1
1.3.6.1.2.1.33.1.6.3.26	upsAlarmAuxInput2
1.3.6.1.2.1.33.1.6.3.27	upsAlarmAuxInput3
1.3.6.1.2.1.33.1.6.3.28	upsAlarmAuxInput4
1.3.6.1.2.1.33.1.6.3.125	alarmSensorManager1Low
1.3.6.1.2.1.33.1.6.3.126	alarmSensorManager2Low
1.3.6.1.2.1.33.1.6.3.127	alarmSensorManager3Low
1.3.6.1.2.1.33.1.6.3.128	alarmSensorManager4Low
1.3.6.1.2.1.33.1.6.3.129	alarmSensorManager5Low
1.3.6.1.2.1.33.1.6.3.130	alarmSensorManager6Low
1.3.6.1.2.1.33.1.6.3.131	alarmSensorManager7Low
1.3.6.1.2.1.33.1.6.3.132	alarmSensorManager8Low
1.3.6.1.2.1.33.1.6.3.133	alarmSensorManager1High
1.3.6.1.2.1.33.1.6.3.134	alarmSensorManager2High
1.3.6.1.2.1.33.1.6.3.135	alarmSensorManager3High
1.3.6.1.2.1.33.1.6.3.136	alarmSensorManager4High
1.3.6.1.2.1.33.1.6.3.137	alarmSensorManager5High
1.3.6.1.2.1.33.1.6.3.138	alarmSensorManager6High
1.3.6.1.2.1.33.1.6.3.139	alarmSensorManager7High
1.3.6.1.2.1.33.1.6.3.140	alarmSensorManager8High
1.3.6.1.2.1.33.1.6.3.141	alarmUser1
1.3.6.1.2.1.33.1.6.3.142	alarmUser2
1.3.6.1.2.1.33.1.6.3.143	alarmUser3
1.3.6.1.2.1.33.1.6.3.144	alarmUser4
1.3.6.1.2.1.33.1.6.3.145	alarmUser5
1.3.6.1.2.1.33.1.6.3.146	alarmUser6
1.3.6.1.2.1.33.1.6.3.147	alarmUser7
1.3.6.1.2.1.33.1.6.3.148	statusDischarging
1.3.6.1.2.1.33.1.6.3.149	statusCharging
1.3.6.1.2.1.33.1.6.3.150	alarmSensorManagerInput1
1.3.6.1.2.1.33.1.6.3.151	alarmSensorManagerInput2

1.3.6.1.2.1.33.1.6.3.152	alarmSensorManagerInput3
1.3.6.1.2.1.33.1.6.3.153	alarmSensorManagerInput4
1.3.6.1.2.1.33.1.6.3.154	alarmSensorManagerOutput1
1.3.6.1.2.1.33.1.6.3.155	alarmSensorManagerOutput2
1.3.6.1.2.1.33.1.6.3.156	alarmSensorManagerOutput3
1.3.6.1.2.1.33.1.6.3.157	alarmSensorManagerOutput4
1.3.6.1.2.1.33.1.6.3.158	alarmSensorComLost
1.3.6.1.2.1.33.1.6.3.159	alarmVuesWindalarm
1.3.6.1.2.1.33.1.6.3.160	alarmTransferswitchSourcesAsynchronous
1.3.6.1.2.1.33.1.6.3.161	alarmTransferswitchStaticSwitchAFailure
1.3.6.1.2.1.33.1.6.3.162	alarmTransferswitchStaticSwitchBFailure
1.3.6.1.2.1.33.1.6.3.163	alarmTransferswitchOnStaticSwitchA
1.3.6.1.2.1.33.1.6.3.164	alarmTransferswitchOnStaticSwitchB
1.3.6.1.2.1.33.1.6.3.165	alarmTransferswitchOnManualBypassA
1.3.6.1.2.1.33.1.6.3.166	alarmTransferswitchOnManualBypassB
1.3.6.1.2.1.33.1.6.3.167	alarmTransferswitchSourceAFailure
1.3.6.1.2.1.33.1.6.3.168	alarmTransferswitchSourceBFailure
1.3.6.1.2.1.33.1.6.3.169	alarmTransferswitchGeneralFault
1.3.6.1.2.1.33.1.6.3.170	alarmTransferswitchRedundancyLost
1.3.6.1.2.1.33.1.6.3.171	alarmTransferswitchOutputOverload
1.3.6.1.2.1.33.1.6.3.172	alarmBlackBoxReady
1.3.6.1.2.1.33.1.6.3.173	upsAlarmInputAuxBad
1.3.6.1.2.1.33.1.7	upsTest
1.3.6.1.2.1.33.1.7.1	upsTestId
1.3.6.1.2.1.33.1.7.2	upsTestSpinLock
1.3.6.1.2.1.33.1.7.3	upsTestResultsSummary
1.3.6.1.2.1.33.1.7.4	upsTestResultsDetail
1.3.6.1.2.1.33.1.7.5	upsTestStartTime
1.3.6.1.2.1.33.1.7.6	upsTestElapsedTime
1.3.6.1.2.1.33.1.7.7	upsWellKnownTests
1.3.6.1.2.1.33.1.7.7.1	upsTestNoTestsInitiated
1.3.6.1.2.1.33.1.7.7.2	upsTestAbortTestInProgress
1.3.6.1.2.1.33.1.7.7.3	upsTestGeneralSystemsTest
1.3.6.1.2.1.33.1.7.7.4	upsTestQuickBatteryTest
1.3.6.1.2.1.33.1.7.7.5	upsTestDeepBatteryCalibration
1.3.6.1.2.1.33.1.8	upsControl
1.3.6.1.2.1.33.1.8.1	upsShutdownType
1.3.6.1.2.1.33.1.8.2	upsShutdownAfterDelay
1.3.6.1.2.1.33.1.8.3	upsStartupAfterDelay
1.3.6.1.2.1.33.1.8.4	upsRebootWithDuration
1.3.6.1.2.1.33.1.8.5	upsAutoRestart
1.3.6.1.2.1.33.1.8.6	UpsVarIdIn Read/Write "for internal purpose only - do not overwrite "
1.3.6.1.2.1.33.1.8.7	UpsVarIdOut Read only "for internal purpose only"
1.3.6.1.2.1.33.1.9	upsConfig
1.3.6.1.2.1.33.1.9.1	upsConfigInputVoltage
1.3.6.1.2.1.33.1.9.2	upsConfigInputFreq
1.3.6.1.2.1.33.1.9.3	upsConfigOutputVoltage
1.3.6.1.2.1.33.1.9.4	upsConfigOutputFreq
1.3.6.1.2.1.33.1.9.5	upsConfigOutputVA
1.3.6.1.2.1.33.1.9.6	upsConfigOutputPower
1.3.6.1.2.1.33.1.9.7	upsConfigLowBattTime
1.3.6.1.2.1.33.1.9.8	upsConfigAudibleStatus
1.3.6.1.2.1.33.1.9.9	upsConfigLowVoltageTransferPoint
1.3.6.1.2.1.33.1.9.10	upsConfigHighVoltageTransferPoint
1.3.6.1.2.1.33.1.10	sitemanager
1.3.6.1.2.1.33.1.10.1	relais
1.3.6.1.2.1.33.1.10.1.1	relais1
1.3.6.1.2.1.33.1.10.1.2	relais2
1.3.6.1.2.1.33.1.10.1.3	relais3
1.3.6.1.2.1.33.1.10.1.4	relais4

1.3.6.1.2.1.33.1.10.1.5	relais5
1.3.6.1.2.1.33.1.10.1.6	relais6
1.3.6.1.2.1.33.1.10.1.7	relais7
1.3.6.1.2.1.33.1.10.1.8	relais8
1.3.6.1.2.1.33.1.10.2	digital
1.3.6.1.2.1.33.1.10.2.1	digital1
1.3.6.1.2.1.33.1.10.2.2	digital2
1.3.6.1.2.1.33.1.10.2.3	digital3
1.3.6.1.2.1.33.1.10.2.4	digital4
1.3.6.1.2.1.33.1.10.2.5	digital5
1.3.6.1.2.1.33.1.10.2.6	digital6
1.3.6.1.2.1.33.1.10.2.7	digital7
1.3.6.1.2.1.33.1.10.2.8	digital8
1.3.6.1.2.1.33.1.10.3	analog
1.3.6.1.2.1.33.1.10.3.1	analog1
1.3.6.1.2.1.33.1.10.3.2	analog1Min
1.3.6.1.2.1.33.1.10.3.3	analog1Max
1.3.6.1.2.1.33.1.10.3.4	analog2
1.3.6.1.2.1.33.1.10.3.5	analog2Min
1.3.6.1.2.1.33.1.10.3.6	analog2Max
1.3.6.1.2.1.33.1.10.3.7	analog3
1.3.6.1.2.1.33.1.10.3.8	analog3Min
1.3.6.1.2.1.33.1.10.3.9	analog3Max
1.3.6.1.2.1.33.1.10.3.10	analog4
1.3.6.1.2.1.33.1.10.3.11	analog4Min
1.3.6.1.2.1.33.1.10.3.12	analog4Max
1.3.6.1.2.1.33.1.10.3.13	analog5
1.3.6.1.2.1.33.1.10.3.14	analog5Min
1.3.6.1.2.1.33.1.10.3.15	analog5Max
1.3.6.1.2.1.33.1.10.3.16	analog6
1.3.6.1.2.1.33.1.10.3.17	analog6Min
1.3.6.1.2.1.33.1.10.3.18	analog6Max
1.3.6.1.2.1.33.1.10.3.19	analog7
1.3.6.1.2.1.33.1.10.3.20	analog7Min
1.3.6.1.2.1.33.1.10.3.21	analog7Max
1.3.6.1.2.1.33.1.10.3.22	analog8
1.3.6.1.2.1.33.1.10.3.23	analog8Min
1.3.6.1.2.1.33.1.10.3.24	analog8Max
1.3.6.1.2.1.33.1.10.4	marker
1.3.6.1.2.1.33.1.10.4.1	marker1
1.3.6.1.2.1.33.1.10.4.2	marker2
1.3.6.1.2.1.33.1.10.4.3	marker3
1.3.6.1.2.1.33.1.10.4.4	marker4
1.3.6.1.2.1.33.1.10.4.5	marker5
1.3.6.1.2.1.33.1.10.4.6	marker6
1.3.6.1.2.1.33.1.10.4.7	marker7
1.3.6.1.2.1.33.1.10.4.8	marker8
1.3.6.1.2.1.33.1.11	aux
1.3.6.1.2.1.33.1.11.1	auxPort1
1.3.6.1.2.1.33.1.11.2	auxPort2
1.3.6.1.2.1.33.1.11.3	auxPort3
1.3.6.1.2.1.33.1.11.4	auxPort4
1.3.6.1.2.1.33.1.12	sensorMan
1.3.6.1.2.1.33.1.12.1	sensor1
1.3.6.1.2.1.33.1.12.1.1	sensorMan1Value
1.3.6.1.2.1.33.1.12.1.2	sensorMan1Location
1.3.6.1.2.1.33.1.12.1.3	sensorMan1Unit
1.3.6.1.2.1.33.1.12.1.4	sensorMan1ThresholdLow
1.3.6.1.2.1.33.1.12.1.5	sensorMan1ThresholdHigh
1.3.6.1.2.1.33.1.12.1.6	sensorMan1Scaling
1.3.6.1.2.1.33.1.12.1.7	sensorMan1Offset
1.3.6.1.2.1.33.1.12.2	sensor2

1.3.6.1.2.1.33.1.12.2.1	sensorMan2Value
1.3.6.1.2.1.33.1.12.2.2	sensorMan2Location
1.3.6.1.2.1.33.1.12.2.3	sensorMan2Unit
1.3.6.1.2.1.33.1.12.2.4	sensorMan2ThresholdLow
1.3.6.1.2.1.33.1.12.2.5	sensorMan2ThresholdHigh
1.3.6.1.2.1.33.1.12.2.6	sensorMan2Scaling
1.3.6.1.2.1.33.1.12.2.7	sensorMan2Offset
1.3.6.1.2.1.33.1.12.3	sensor3
1.3.6.1.2.1.33.1.12.3.1	sensorMan3Value
1.3.6.1.2.1.33.1.12.3.2	sensorMan3Location
1.3.6.1.2.1.33.1.12.3.3	sensorMan3Unit
1.3.6.1.2.1.33.1.12.3.4	sensorMan3ThresholdLow
1.3.6.1.2.1.33.1.12.3.5	sensorMan3ThresholdHigh
1.3.6.1.2.1.33.1.12.3.6	sensorMan3Scaling
1.3.6.1.2.1.33.1.12.3.7	sensorMan3Offset
1.3.6.1.2.1.33.1.12.4	sensor4
1.3.6.1.2.1.33.1.12.4.1	sensorMan4Value
1.3.6.1.2.1.33.1.12.4.2	sensorMan4Location
1.3.6.1.2.1.33.1.12.4.3	sensorMan4Unit
1.3.6.1.2.1.33.1.12.4.4	sensorMan4ThresholdLow
1.3.6.1.2.1.33.1.12.4.5	sensorMan4ThresholdHigh
1.3.6.1.2.1.33.1.12.4.6	sensorMan4Scaling
1.3.6.1.2.1.33.1.12.4.7	sensorMan4Offset
1.3.6.1.2.1.33.1.12.5	sensor5
1.3.6.1.2.1.33.1.12.5.1	sensorMan5Value
1.3.6.1.2.1.33.1.12.5.2	sensorMan5Location
1.3.6.1.2.1.33.1.12.5.3	sensorMan5Unit
1.3.6.1.2.1.33.1.12.5.4	sensorMan5ThresholdLow
1.3.6.1.2.1.33.1.12.5.5	sensorMan5ThresholdHigh
1.3.6.1.2.1.33.1.12.5.6	sensorMan5Scaling
1.3.6.1.2.1.33.1.12.5.7	sensorMan5Offset
1.3.6.1.2.1.33.1.12.6	sensor6
1.3.6.1.2.1.33.1.12.6.1	sensorMan6Value
1.3.6.1.2.1.33.1.12.6.2	sensorMan6Location
1.3.6.1.2.1.33.1.12.6.3	sensorMan6Unit
1.3.6.1.2.1.33.1.12.6.4	sensorMan6ThresholdLow
1.3.6.1.2.1.33.1.12.6.5	sensorMan6ThresholdHigh
1.3.6.1.2.1.33.1.12.6.6	sensorMan6Scaling
1.3.6.1.2.1.33.1.12.6.7	sensorMan6Offset
1.3.6.1.2.1.33.1.12.7	sensor7
1.3.6.1.2.1.33.1.12.7.1	sensorMan7Value
1.3.6.1.2.1.33.1.12.7.2	sensorMan7Location
1.3.6.1.2.1.33.1.12.7.3	sensorMan7Unit
1.3.6.1.2.1.33.1.12.7.4	sensorMan7ThresholdLow
1.3.6.1.2.1.33.1.12.7.5	sensorMan7ThresholdHigh
1.3.6.1.2.1.33.1.12.7.6	sensorMan7Scaling
1.3.6.1.2.1.33.1.12.7.7	sensorMan7Offset
1.3.6.1.2.1.33.1.12.8	sensor8
1.3.6.1.2.1.33.1.12.8.1	sensorMan8Value
1.3.6.1.2.1.33.1.12.8.2	sensorMan8Location
1.3.6.1.2.1.33.1.12.8.3	sensorMan8Unit
1.3.6.1.2.1.33.1.12.8.4	sensorMan8ThresholdLow
1.3.6.1.2.1.33.1.12.8.5	sensorMan8ThresholdHigh
1.3.6.1.2.1.33.1.12.8.6	sensorMan8Scaling
1.3.6.1.2.1.33.1.12.8.7	sensorMan8Offset
1.3.6.1.2.1.33.1.12.9	input1
1.3.6.1.2.1.33.1.12.9.1	input1Value
1.3.6.1.2.1.33.1.12.9.2	input1Location
1.3.6.1.2.1.33.1.12.9.3	input1NCContakt
1.3.6.1.2.1.33.1.12.10	input2
1.3.6.1.2.1.33.1.12.10.1	input2Value
1.3.6.1.2.1.33.1.12.10.2	input2Location

1.3.6.1.2.1.33.1.12.10.3	input2NCContact
1.3.6.1.2.1.33.1.12.11	input3
1.3.6.1.2.1.33.1.12.11.1	input3Value
1.3.6.1.2.1.33.1.12.11.2	input3Location
1.3.6.1.2.1.33.1.12.11.3	input3NCContact
1.3.6.1.2.1.33.1.12.12	input4
1.3.6.1.2.1.33.1.12.12.1	input4Value
1.3.6.1.2.1.33.1.12.12.2	input4Location
1.3.6.1.2.1.33.1.12.12.3	inputNCContact
1.3.6.1.2.1.33.1.12.13	output1
1.3.6.1.2.1.33.1.12.13.1	output1Value
1.3.6.1.2.1.33.1.12.13.2	output1Location
1.3.6.1.2.1.33.1.12.13.3	output1NCContact
1.3.6.1.2.1.33.1.12.14	output2
1.3.6.1.2.1.33.1.12.14.1	output2Value
1.3.6.1.2.1.33.1.12.14.2	output2Location
1.3.6.1.2.1.33.1.12.14.3	output2NCContact
1.3.6.1.2.1.33.1.12.15	output3
1.3.6.1.2.1.33.1.12.15.1	output3Value
1.3.6.1.2.1.33.1.12.15.2	output3Location
1.3.6.1.2.1.33.1.12.15.3	output3NCContact
1.3.6.1.2.1.33.1.12.16	output4
1.3.6.1.2.1.33.1.12.16.1	output4Value
1.3.6.1.2.1.33.1.12.16.2	output4Location
1.3.6.1.2.1.33.1.12.16.3	outputNCContact
1.3.6.1.2.1.33.1.13	sts
1.3.6.1.2.1.33.1.13.1	stsStaticSwitch1On
1.3.6.1.2.1.33.1.13.2	stsStaticSwitch2On
1.3.6.1.2.1.33.1.13.3	stsManualBypass1On
1.3.6.1.2.1.33.1.13.4	stsManualBypass2On
1.3.6.1.2.1.33.1.13.5	stsAutoTransfermode
1.3.6.1.2.1.33.1.13.6	stsSourcesSynchron
1.3.6.1.2.1.33.1.13.7	stsPreferedMains1
1.3.6.1.2.1.33.1.13.8	stsPreferedMains2
1.3.6.1.2.1.33.1.13.9	stsAutostartEnabled
1.3.6.1.2.1.33.1.14	upsInputAux
1.3.6.1.2.1.33.1.14.1	upsInputAuxBads
1.3.6.1.2.1.33.1.14.2	upsInputAuxNumLines
1.3.6.1.2.1.33.1.14.3	upsInputAuxTable
1.3.6.1.2.1.33.1.14.3.1	upsInputAuxEntry
1.3.6.1.2.1.33.1.14.3.1.1	upsInputAuxIndex
1.3.6.1.2.1.33.1.14.3.1.2	upsInputAuxFrequency
1.3.6.1.2.1.33.1.14.3.1.3	upsInputAuxVoltage
1.3.6.1.2.1.33.1.14.3.1.4	upsInputAuxCurrent
1.3.6.1.2.1.33.1.14.3.1.5	upsInputAuxTruePower
1.3.6.1.2.1.33.1.15	additionalValues
1.3.6.1.2.1.33.1.15.1	externalSensor
1.3.6.1.2.1.33.2	upsTraps
1.3.6.1.2.1.33.2.1	upsTrapOnBattery
1.3.6.1.2.1.33.2.2	upsTrapTestCompleted
1.3.6.1.2.1.33.2.3	upsTrapAlarmEntryAdded
1.3.6.1.2.1.33.2.4	upsTrapAlarmEntryRemoved
1.3.6.1.2.1.33.3	upsConformance
1.3.6.1.2.1.33.3.1	upsCompliances
1.3.6.1.2.1.33.3.1.1	upsSubsetCompliance
1.3.6.1.2.1.33.3.1.2	upsBasicCompliance
1.3.6.1.2.1.33.3.1.3	upsFullCompliance
1.3.6.1.2.1.33.3.2	upsGroups
1.3.6.1.2.1.33.3.2.1	upsSubsetGroups
1.3.6.1.2.1.33.3.2.1.1	upsSubsetIdentGroup
1.3.6.1.2.1.33.3.2.1.2	upsSubsetBatteryGroup
1.3.6.1.2.1.33.3.2.1.3	upsSubsetInputGroup

1.3.6.1.2.1.33.3.2.1.4	upsSubsetOutputGroup
1.3.6.1.2.1.33.3.2.1.6	upsSubsetAlarmGroup
1.3.6.1.2.1.33.3.2.1.8	upsSubsetControlGroup
1.3.6.1.2.1.33.3.2.1.9	upsSubsetConfigGroup
1.3.6.1.2.1.33.3.2.2	upsBasicGroups
1.3.6.1.2.1.33.3.2.2.1	upsBasicIdentGroup
1.3.6.1.2.1.33.3.2.2.2	upsBasicBatteryGroup
1.3.6.1.2.1.33.3.2.2.3	upsBasicInputGroup
1.3.6.1.2.1.33.3.2.2.4	upsBasicOutputGroup
1.3.6.1.2.1.33.3.2.2.5	upsBasicBypassGroup
1.3.6.1.2.1.33.3.2.2.6	upsBasicAlarmGroup
1.3.6.1.2.1.33.3.2.2.7	upsBasicTestGroup
1.3.6.1.2.1.33.3.2.2.8	upsBasicControlGroup
1.3.6.1.2.1.33.3.2.2.9	upsBasicConfigGroup
1.3.6.1.2.1.33.3.2.3	upsFullGroups
1.3.6.1.2.1.33.3.2.3.1	upsFullIdentGroup
1.3.6.1.2.1.33.3.2.3.2	upsFullBatteryGroup
1.3.6.1.2.1.33.3.2.3.3	upsFullInputGroup
1.3.6.1.2.1.33.3.2.3.4	upsFullOutputGroup
1.3.6.1.2.1.33.3.2.3.5	upsFullBypassGroup
1.3.6.1.2.1.33.3.2.3.6	upsFullAlarmGroup
1.3.6.1.2.1.33.3.2.3.7	upsFullTestGroup
1.3.6.1.2.1.33.3.2.3.8	upsFullControlGroup
1.3.6.1.2.1.33.3.2.3.9	upsFullConfigGroup

## RFC 1628 MIB – EQUALINK extension

This ist the overview of the RFC 1628 EQUALINK extention. At [www.Exponential Power.de](http://www.Exponential Power.de) , you can download theMIB file and use it with your SNMP monitoring system.

## EQUALINK2 MIB

1.3.6.1.2.1	mib2
1.3.6.1.2.1.33	upsMIB
1.3.6.1.2.1.33.5	EquaLink2
1.3.6.1.2.1.33.5.1	EquaLinkSettings
1.3.6.1.2.1.33.5.1.1	EquaLinkModuleType
1.3.6.1.2.1.33.5.1.2	EquaLinkNumStrings
1.3.6.1.2.1.33.5.1.3	EquaLinkNumBatteries
1.3.6.1.2.1.33.5.1.4	EquaLinkBattCap
1.3.6.1.2.1.33.5.1.5	EquaLinkLogRate1
1.3.6.1.2.1.33.5.1.6	EquaLinkLogRate2
1.3.6.1.2.1.33.5.1.7	EquaLinkImpcPollRate
1.3.6.1.2.1.33.5.1.8	EquaLinkImpcLowAlarm
1.3.6.1.2.1.33.5.1.9	EquaLinkImpcHighAlarm
1.3.6.1.2.1.33.5.1.10	EquaLinkTemperatureLowAlarm
1.3.6.1.2.1.33.5.1.11	EquaLinkTemperatureHighAlarm
1.3.6.1.2.1.33.5.1.12	EquaLinkVoltageLowAlarm
1.3.6.1.2.1.33.5.1.13	EquaLinkVoltageHighAlarm
1.3.6.1.2.1.33.5.1.14	EquaLinkImpcLowWarn
1.3.6.1.2.1.33.5.1.15	EquaLinkImpcHighWarn
1.3.6.1.2.1.33.5.1.16	EquaLinkTemperatureLowWarn
1.3.6.1.2.1.33.5.1.17	EquaLinkTemperatureHighWarn
1.3.6.1.2.1.33.5.1.18	EquaLinkVoltageLowWarn
1.3.6.1.2.1.33.5.1.19	EquaLinkVoltageHighWarn
1.3.6.1.2.1.33.5.1.20	EquaLinkTemperatureUnit
1.3.6.1.2.1.33.5.2	EquaLinkObjects

1.3.6.1.2.1.33.5.2.1	EquaLinkStatus
1.3.6.1.2.1.33.5.2.2	EquaLinkAvModuleVolt
1.3.6.1.2.1.33.5.2.3	EquaLinkTotalVolt
1.3.6.1.2.1.33.5.2.4	EquaLinkNumModules
1.3.6.1.2.1.33.5.2.5	EquaLinkModuleTable
1.3.6.1.2.1.33.5.2.5.1	EquaLinkModuleEntry
1.3.6.1.2.1.33.5.2.5.1.1	EquaLinkModuleIndex
1.3.6.1.2.1.33.5.2.5.1.2	EquaLinkModuleVoltage
1.3.6.1.2.1.33.5.2.5.1.3	EquaLinkModuleTemperature
1.3.6.1.2.1.33.5.2.5.1.4	EquaLinkModuleBypass
1.3.6.1.2.1.33.5.2.5.1.5	EquaLinkModuleResistance
1.3.6.1.2.1.33.5.2.5.1.6	EquaLinkModuleState
1.3.6.1.2.1.33.5.2.6	EquaLinkNumStrings
1.3.6.1.2.1.33.5.2.7	EquaLinkStringTable
1.3.6.1.2.1.33.5.2.7.1	EquaLinkStringEntry
1.3.6.1.2.1.33.5.2.7.1.1	EquaLinkStringIndex
1.3.6.1.2.1.33.5.2.7.1.2	EquaLinkStringCurrent
1.3.6.1.2.1.33.5.2.7.1.3	EquaLinkStringTotalVolt
1.3.6.1.2.1.33.5.2.7.1.4	EquaLinkStringAverageVolt
1.3.6.1.2.1.33.5.3	EquaLinkAlarms
1.3.6.1.2.1.33.5.3.1	EquaLinkAlarmsPresent
1.3.6.1.2.1.33.5.3.2	EquaLinkAlarmTable
1.3.6.1.2.1.33.5.3.2.1	EquaLinkAlarmEntry
1.3.6.1.2.1.33.5.3.2.1.1	EquaLinkAlarmId
1.3.6.1.2.1.33.5.3.2.1.2	EquaLinkAlarmDescr
1.3.6.1.2.1.33.5.3.2.1.3	EquaLinkAlarmTime
1.3.6.1.2.1.33.5.3.3	EquaLinkWellKnownAlarms
1.3.6.1.2.1.33.5.3.3.1	EquaLinkAlarmSystemError
1.3.6.1.2.1.33.5.3.3.2	EquaLinkAlarmResistWarn
1.3.6.1.2.1.33.5.3.3.3	EquaLinkAlarmResistAlarm
1.3.6.1.2.1.33.5.3.3.4	EquaLinkAlarmVoltage
1.3.6.1.2.1.33.5.3.3.5	EquaLinkAlarmTemperature
1.3.6.1.2.1.33.5.3.3.6	EquaLinkAlarmVoltageHigh
1.3.6.1.2.1.33.5.3.3.7	EquaLinkAlarmVoltageLow
1.3.6.1.2.1.33.5.3.3.8	EquaLinkAlarmTemperatureHigh
1.3.6.1.2.1.33.5.3.3.9	EquaLinkAlarmTemperatureLow
1.3.6.1.2.1.33.5.3.3.10	EquaLinkAlarmResistAlarmHigh
1.3.6.1.2.1.33.5.3.3.11	EquaLinkAlarmResistAlarmLow
1.3.6.1.2.1.33.5.3.3.12	EquaLinkAlarmEqualizing
1.3.6.1.2.1.33.5.3.3.13	EquaLinkAlarmVoltageWarnHigh
1.3.6.1.2.1.33.5.3.3.14	EquaLinkAlarmVoltageWarnLow
1.3.6.1.2.1.33.5.3.3.15	EquaLinkAlarmTemperatureWarnHigh
1.3.6.1.2.1.33.5.3.3.16	EquaLinkAlarmTemperatureWarnLow
1.3.6.1.2.1.33.5.3.3.17	EquaLinkAlarmResistWarnHigh
1.3.6.1.2.1.33.5.3.3.18	EquaLinkAlarmResistWarnLow
1.3.6.1.2.1.33.5.3.3.19	EquaLinkAlarmInitializing
1.3.6.1.2.1.33.5.3.3.20	EquaLinkAlarmCommunicationLost
1.3.6.1.2.1.33.5.3.3.21	EquaLinkAlarmBatteryBreakerOpen
1.3.6.1.2.1.33.5.3.3.22	EquaLinkAlarmThermalRunaway
1.3.6.1.2.1.33.5.3.3.23	EquaLinkAlarmSensorCommunicationLost
1.3.6.1.2.1.33.5.3.3.24	EquaLinkAlarmDischarging
1.3.6.1.2.1.33.5.3.3.25	EquaLinkAlarmDischargingStopped
1.3.6.1.2.1.33.5.3.3.26	EquaLinkAlarmMaxVoltageDiff
1.3.6.1.2.1.33.5.4	EquaLinkTraps
1.3.6.1.2.1.33.5.4.1	EquaLinkTrapAlarmEntryAdded
1.3.6.1.2.1.33.5.4.2	EquaLinkTrapAlarmEntryRemoved
1.3.6.1.2.1.33.5.5	gxRAUX
1.3.6.1.2.1.33.5.5.1	gxRAUX1Input1
1.3.6.1.2.1.33.5.5.2	gxRAUX1Input2



1.3.6.1.2.1.33.5.5.3	gxRAUX1Input3
1.3.6.1.2.1.33.5.5.4	gxRAUX1Input4
1.3.6.1.2.1.33.5.5.5	gxRAUX1Output1
1.3.6.1.2.1.33.5.5.6	gxRAUX1Output2
1.3.6.1.2.1.33.5.5.7	gxRAUX1Output3
1.3.6.1.2.1.33.5.5.8	gxRAUX1Output4
1.3.6.1.2.1.33.5.5.9	gxRAUX2Input1
1.3.6.1.2.1.33.5.5.10	gxRAUX2Input2
1.3.6.1.2.1.33.5.5.11	gxRAUX2Input3
1.3.6.1.2.1.33.5.5.12	gxRAUX2Input4
1.3.6.1.2.1.33.5.5.13	gxRAUX2Output1
1.3.6.1.2.1.33.5.5.14	gxRAUX2Output2
1.3.6.1.2.1.33.5.5.15	gxRAUX2Output3
1.3.6.1.2.1.33.5.5.16	gxRAUX2Output4
1.3.6.1.2.1.33.5.5.17	gxRAUX3Input1
1.3.6.1.2.1.33.5.5.18	gxRAUX3Input2
1.3.6.1.2.1.33.5.5.19	gxRAUX3Input3
1.3.6.1.2.1.33.5.5.20	gxRAUX3Input4
1.3.6.1.2.1.33.5.5.21	gxRAUX3Output1
1.3.6.1.2.1.33.5.5.22	gxRAUX3Output2
1.3.6.1.2.1.33.5.5.23	gxRAUX3Output3
1.3.6.1.2.1.33.5.5.24	gxRAUX3Output4
1.3.6.1.2.1.33.5.5.25	gxRAUX4Input1
1.3.6.1.2.1.33.5.5.26	gxRAUX4Input2
1.3.6.1.2.1.33.5.5.27	gxRAUX4Input3
1.3.6.1.2.1.33.5.5.28	gxRAUX4Input4
1.3.6.1.2.1.33.5.5.29	gxRAUX4Output1
1.3.6.1.2.1.33.5.5.30	gxRAUX4Output2
1.3.6.1.2.1.33.5.5.31	gxRAUX4Output3
1.3.6.1.2.1.33.5.5.32	gxRAUX4Output4

## **Copyright and licenses**

*The copyright authorization from Exponential Power and other relevant software suppliers must be respected. Exponential Power and their suppliers reserve the rights to the software components. In particular the following are prohibited:*

- *copying and distribution,*
- *modifications and derivations,*
- *decompilation, reverse engineering,*

*Components which fall under GNU General Public License and further Open Source licenses are integrated into the software. An overview of the integrated Open Source components and a copy of the current license can be obtained at [www.Exponential Power.com](http://www.Exponential Power.com)*

*Exponential Power will provide the source code for all components of software licensed under the GNU GeneralPublic License and comparable Open Source licenses.*

*For source code requests, please email [te@Exponential Power.com](mailto:te@Exponential Power.com)*