



# **SBS-MicroSMART MXT**

## **High Frequency Battery Charger**

Installation and Operation Manual



Storage Battery Systems LLC  
N56 W16665 Ridgewood Drive  
Menomonee Falls, WI 53051

[www.sbsbattery.com](http://www.sbsbattery.com)

800-554-2243

[sbs@sbsbattery.com](mailto:sbs@sbsbattery.com)

## **Storage Battery Systems, LLC Industrial Battery Charger Warranty**

This Warranty Agreement entered between Storage Battery Systems, LLC (SBS) and the Original End User is with respect to SBS motive power battery charger product lines as stated above, for industrial electrical truck battery charging usage.

**1.0 GENERAL:** SBS warrants that each new industrial battery charger supplied by it, is of good workmanship and is free from any inherent mechanical defects, provided:

**1.1** The product is installed and operated in accordance with generally accepted industrial standards and in accordance with the printed instructions supplied with the charger.

**1.2** The charger is used under conditions for which it was designed and is not subject to misuse, negligence or accident.

**1.3** The charger receives proper care, protection, and maintenance under supervision of qualified personnel.

**1.4** The charger is used within the published performance rating for the unit involved.

**1.5** The charger is used exclusively by the original end-user and by no other persons.

**2.0 PERSONS COVERED:** The charger is fully warranted for 3 years from the date of shipment by SBS to the original end user, with the following exceptions:

**2.1** Power transformer is warranted for an additional 5 years parts only F.O.B. Menomonee Falls, WI.

**2.2** Primary switch contacts, fuses, bulbs, and filters are not warranted unless found to be defective prior to use.

**3.0 LIMITATION OF REMEDY** Any claimed defect is subject to SBS's inspection and judgment, after the original user at its expense has returned the defective product to SBS, Menomonee Falls, WI.

**3.1** SBS's liability is limited to the repair of the defect or, at SBS's option, the replacement of the defective parts. During the 3-year warranty period, SBS will bear all freight, (within the contiguous 48 states) parts, and labor costs per published warranty rate schedule of such repair or replacement. During the last 5 years of the warranty on power transformers, SBS will bear the cost of replacement parts only; no labor or other services will be provided by SBS. SBS shall not be obligated to reimburse the original end user or any other person for any work performed.

**3.2** Replacement parts will be warranted for the remainder of the original warranty period as defined above, or for 30 days; whichever is greater.

**3.3** SBS shall not be liable for direct or indirect, special or consequential damages in excess of such repair or replacement. In no event shall the original end user be entitled to recover for contingent expenses resulting from, but not limited to, telephone calls, telegrams, travel expenses, lodging, duties and taxes, labor, rental of replacement equipment, loss of business or profits or other commercial losses.

**4.0 USE OF DEFECTIVE PRODUCT:** Continued use of a defective charger after discovery of a defect will void all warranties.

**5.0 REPAIRED EQUIPMENT:** Except as authorized in writing, this warranty does not cover any equipment that has been repaired by any party other than an authorized SBS service agent.

**6.0 MODIFIED EQUIPMENT:** This warranty is void if this equipment has been modified without written permission from SBS.

**7.0 NOT COVERED:** Failure due to imbalance of incoming A/C line, line harmonics (distortion) or disconnecting the charger while under load will not be covered.

EXCEPT AS STATED ABOVE, ALL OTHER WARRANTIES AND CONDITIONS, EITHER EXPRESS OR IMPLIED, INCLUDING IMPLIED WARRANTIES OR MERCHANTABILITY AND FITNESS FOR A PARTICULAR PURPOSE, ARE EXCLUDED AND ORIGINAL END USER ASSUMES ALL RISK AND LIABILITY RESULTING FROM USE OF THE PRODUCT. SBS NEITHER ASSUMES NOR AUTHORIZES ANY PERSON TO ASSUME FOR SBS ANY OTHER LIABILITY IN CONNECTION WITH THE SALE OR USE OF THE PRODUCT AND THERE ARE NO ORAL AGREEMENTS OR WARRANTIES COLLATERAL TO OR AFFECTING THIS WRITTEN WARRANTY.

# INDEX

---

<b>Page</b>	<b>Section</b>	<b>Description</b>
4	-	Safety Instructions
5	1.0	Installation
5	1.1	Receiving
5	1.2	Location
5	1.3	Line Voltage
6	1.4	AC Service Requirements
6	1.5	Connecting AC Service to Charger
6	1.6	Grounding the Charger
6	1.7	Battery Connector and Charger Cable
7-13	2.0	Operation
7	2.1	046-0304 Control
11-12		Charge Indications
13		Module LED Codes
14	3.0	Troubleshooting & Maintenance
15	4.0	Replaceable Parts
15	4.1	Ordering Information
15	4.2	Recommended Spares
15	4.3	Spare Parts List
16-17		Schematics

# SAFETY INSTRUCTIONS

## WARNING

THIS EQUIPMENT CONTAINS LETHAL VOLTAGE LEVELS. INSTALLATION AND SERVICING MUST BE PERFORMED BY QUALIFIED PERSONNEL

## IMPORTANT: SAVE THESE INSTRUCTIONS!

READ AND FOLLOW ALL INSTRUCTIONS BEFORE INSTALLING, OPERATING, OR SERVICING CHARGER. ANY DEVIATION CAN CAUSE SERIOUS AND PERMANENT DAMAGE. FAILURE TO FOLLOW THE INSTRUCTIONS VOIDS THE WARRANTY.

1. Install and ground the charger in accordance with the National Electric Code and your local electric code. Failure to properly ground the charger could result in a fatal electric shock.
2. "CAUTION" – Risk of fire. Use only on circuits provided with 30 amperes branch circuit protection in accordance with the National Electrical Code, NFPA70.
3. To reduce the risk of fire, install chargers on a surface of non-combustible material, such as concrete, stone, brick or grounded metal.
4. This charger has been designed to charge many chemistries of battery, the appropriate charge algorithm for the chemistry of battery to be charged must be set in the controller. (Lead-acid flooded or sealed, Ni-Cad and Lithium Ion)
5. Connect only batteries of the same number of cells as listed on the charger nameplate. Damage to the battery could occur, particularly if the battery has fewer cells than the rating of the charger.
6. Do not touch uninsulated parts of the output connector or battery terminals. A possibility of serious electrical shock exists.
7. During charge, batteries produce hydrogen gas, which can explode if ignited. Never smoke, use an open flame, or create sparks in the vicinity of the battery. Ventilate well when the battery is in an enclosed space.
8. Do not connect or disconnect the battery plug while the charger is on. Doing so will cause arcing and burning of the connector possibly resulting in charger damage or battery explosion and will void the charger warranty.
9. Lead-acid batteries contain sulfuric acid, which is caustic and can cause chemical burns to the skin. Refer to the battery manufacturer's instructions for safe handling of batteries. Use proper personnel protective equipment. Do not get in eyes, on skin, or on clothing. In cases of contact with eyes, flush immediately with clean water for 15 minutes. Seek medical attention immediately.
10. Do not operate the charger with any panels removed. De-energize all AC and DC power connections before servicing the charger.
11. The charger is not for outdoor use. Do not expose the charger to water spray, rain or snow.
12. Do not operate the charger with damaged cables, including cables with exposed conductors or damaged connectors. Replace damaged cables before operation.
13. Do not operate the charger if it has been dropped, received a sharp blow, or otherwise damaged in any way. Call your service representative.

## SECTION 1 - INSTALLATION

### 1.1. Receiving

Immediately upon receipt of the charger, check it against the shipping invoice to ensure the shipment is complete and undamaged.

Examine the outside of the packing for signs of rough handling before accepting the charger from the carrier.

If there is evidence of damage, the receipt should be signed, and both copies (carrier's and receiving copies) marked "Shipment Received Damaged". The carrier's representative should be called immediately and asked to make a "Carrier's Damage Report".

If concealed damage is later detected, the carrier should be called and requested to make a "Carrier's Inspection for Concealed Damage Report".

After inspection by the carrier, arrangements should be made with the charger representative to have the charger repaired before placing it in service.

When contacting your charger representative for assistance on a damage claim or shipment error, provide the Model, and Serial Number of the charger, and a full description of the damage or error.

It is good practice to move the charger to the installation site before uncrating. When using bars, hammers, etc. for uncrating, use care to avoid damage to the charger.

**WARNING: To reduce the risk of fire, install the battery charger on a non-combustible surface such as concrete, stone, brick, or steel. DO NOT operate the charger on its shipping skid materials.**

### 1.2. Location

For the best operating conditions and longest life, take care in selecting an installation site. Avoid locations exposed to high humidity, temperature extremes or dust. Moisture condensing on machine parts and electrical components can cause corrosion, which seriously affects operation, efficiency and life. The charger is designed to be used in an ambient temperature of 0-40°C and a relative humidity of 0-90% non-condensing. All units are designed for wall/stand or floor mounting.

Dust and dirt will also decrease heat radiation from heat-generating components, such as transformers and diodes. This will result in higher operating temperatures and shorter life. Adequate air circulation is needed at all times in order to ensure proper operation. Provide a minimum of 6 inches of free air space at the sides of the charger. The front of the charger must remain unobstructed for clean air intake and serviceability. The top must remain unobstructed for serviceability.

### 1.3. Line Voltage

The HF chargers are designed and shipped set for a specific AC line voltage range and phase. The nominal AC line voltage and appropriate phase is noted on the charger nameplate. Before connecting the charger to the AC service, it should be verified that the charger AC voltage and phase matches the available AC service voltage.

## 1.4. AC Service Requirements

Follow local code requirements if they are different than the instructions in this manual. Refer to Table 1-1, to determine the correct ratings for the AC cable, AC fuses, and AC service disconnect switch for the line amperes as listed on the nameplate of the charger for the available AC voltage.

**“CAUTION” – Risk of fire. Use only on circuits provided with 30 amperes branch circuit protection in accordance with the National Electrical Code, NFPA70.**

Line Amperes	Disconnect Switch	Fuse Size Amps
000.0 - 02.5	30A	05
003.0 - 04.5	30A	07
005.0 - 07.5	30A	10
008.0 - 11.0	30A	15
011.5 - 15.5	30A	20
016.0 - 18.0	30A	25
018.5 - 22.0	30A	30
022.5 - 27.0	60A	35
027.5 - 32.0	60A	40
032.5 - 40.0	60A	50
040.5 - 48.0	60A	60
048.5 - 64.0	80A	80
065.0 - 80.0	100A	100
081.0 - 95.0	125A	125
096.0 - 125.0	150A	150

For voltages up to 240, use a 240 volt disconnect switch.

For voltages greater than 240 to 600, use a 600 volt disconnect switch.

- Three conductors and ground wire required for three-phase

## 1.5. Connecting AC Service to the Charger

### Three-Phase Models

Connect the AC service to the L1, L2 and L3 terminals located on the AC connection block.

## 1.6 Grounding the Charger

The charger must be grounded to the AC system ground for personnel safety.

The green ground wire in the AC input wiring must be connected to the charger ground stud identified by a green dot and ground symbol.

## 1.7 Battery Connector and Charging Cable

Verify that the connectors on both the battery and the charger are attached so that the positive output terminal of the charger is connected to the positive battery terminal.

**CAUTION: If the polarity is reversed, the DC fuse will blow.  
If in doubt, check the polarity with a DC voltmeter.**

## SECTION 2 - OPERATION

### 2.1 DESCRIPTION

The 046-0304 charger control provides fully automatic battery charging. The presence of a battery is detected by the control and causes a charge cycle to begin automatically. The control has charging profiles that handle standard flooded, gel-cell, and sealed lead-acid batteries, as well as other battery types such as nickel-cadmium and Li. Each charging profile, or algorithm, uniquely controls the output current and voltage to optimally charge a particular type of battery, based on battery manufacturer's recommendations. The control can be set to start charging at a certain time of day.

#### Keypad

The keypad has 4 directional buttons, UP(+), DOWN(-), LEFT(=), RIGHT(info), and a center On/Off (I/O) button.

- To terminate a charge cycle, press the I/O button
- To select/unselect an equalize cycle for the current charge, press the LEFT(=) button
- To view additional charge data during a charge cycle, press the RIGHT(info) button. The data area of the display will show the data and the units area will display the units for the parameter being displayed. Press RIGHT(info) again for additional data. After 10 seconds, the display will return to the normal display of amps.
- To view charge history, press the UP(+) or DOWN(-) buttons to display a previous charge cycle. The charge cycle number will be displayed in the charge cycle message area and the data will be displayed in the data area along with the units in the units area. Cycle 1 is the most recent and 100 is the oldest. To view additional data for the charge cycle, press the RIGHT(info) button. The data area of the display will show the data and the units area will display the units for the parameter being displayed. Press RIGHT(info) again for additional data. After 10 seconds, the display will return to the normal display of amps.

#### LED Indication

The keypad center I/O button has a multi-color LED backlight to indicate charger status.

LED COLOR	STATUS
Flashing GREEN	Charger ready for battery
Solid GREEN	Charge complete
Flashing AMBER	Charging
Solid AMBER	Battery connected. Charger OFF
Solid RED	Abnormal charge detected

## 46-304 Control Reference Guide

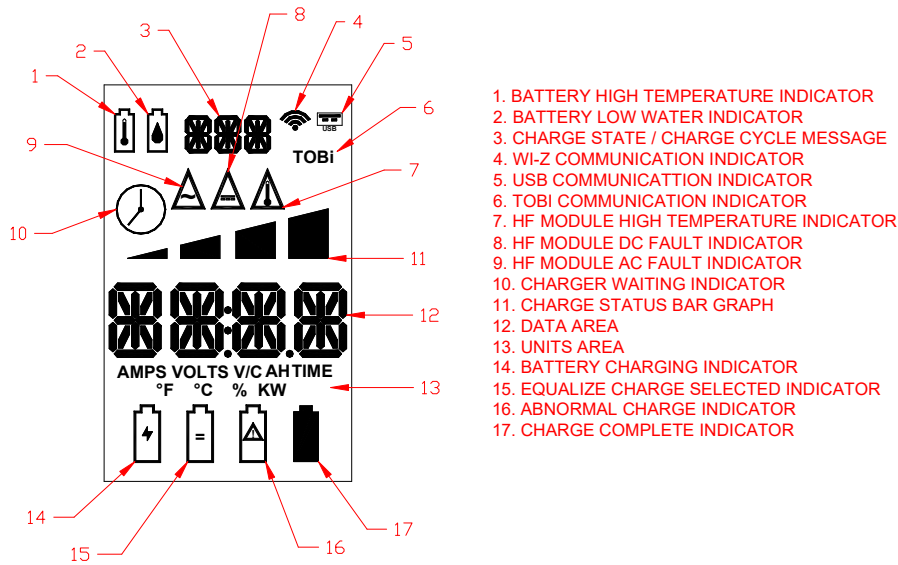

### Display Icons

1. The battery high temperature indicator will be displayed when a battery connected to the charger having a Tobi PI installed is above the OK to charge temperature stored in the Tobi.
2. The battery low water indicator will be displayed when a battery connected to the charger having a Tobi PI installed detects low water and the charge cycle is complete.
3. The charge state/charge cycle message area is used to indicate the charger state during normal operation. It will display the charge cycle number when reviewing charge history.
4. The Wi-Z communication indicator will be displayed when the charger is connected to a Wi-Z network and communicating with the coordinator.
5. N/A.
6. The TOBi communication indicator will be displayed when a battery connected to the charger having a Tobi PI installed is communicating with the charger.
7. The HF module high temperature indicator will be displayed when an HF module in the charger has exceeded the safe operating temperature.
8. The HF module DC fault indicator will be displayed when an HF module in the charger has detected a fault on the DC output.
9. The HF module AC fault indicator will be displayed when an HF module in the charger has detected a fault on the AC input.
10. The charger waiting indicator will be displayed when the charger is in a wait state.
11. The charge status bar graph displays the status of the charge cycle.
12. The data area will display charging amps during a charge cycle. It will display additional charge data when reviewing charge parameters and will display data for previous charge cycles when reviewing history.
13. The units are will display the units for the value shown in the data area.
14. The battery charging indicator will be displayed when the charger is on and charging.
15. The equalize charge selected indicator will be displayed when an equalize cycle has been selected for the current charge cycle.
16. The abnormal charge indicator will be displayed when the charger detects an abnormal charge condition.
17. The charge complete indicator will be displayed when the charge cycle is complete.



## OPERATION

With no battery connected, the control displays '**CONNECT BATTERY**' and the keypad will be flashing GREEN. When a battery is connected, a lamp test is performed. The charge then begins and the keypad will be flashing AMBER. The display show '**CP1**' along with the charging amps. If equalize is active, an '=' icon appears on the display to indicate an equalizing charge.

When phase 1 is completed, the charger starts phase 2 of the charge cycle. The display shows '**CP2**' along with the charging amps. Depending on the charger and battery type, the charger may utilize up to 4 phases to complete a charge.

During the equalize portion of the charge cycle the display shows '**EQU**' along with the charging amps.

When a charge is finished, the charger automatically turns off. The display shows a full battery icon and the keypad will be solid GREEN. The battery may then be disconnected at any time.

## EQUALIZE CHARGE

Over time batteries can develop inequalities in cell charge. This can lower the effective capacity of the battery and shorten life. An equalizing charge re-balances the charge in the battery cells. Perform an equalize charge if any of the following conditions exist:

1. On flooded batteries, the specific gravity of any cell at the end of charge is 20 points less than the average of all the cells.
2. The on-charge voltage of any cell at the end of charge is 20 millivolts less than the average of all the cells.
3. The battery has been stored for 30 days.

The control can perform an equalize automatically based on the number of charge cycles or on a specific day of the week. Normal equalize consists of an additional charge time at the end of a normal charge cycle.

The control can also perform an equalize charge when requested manually. Press the left arrow (=) button. The equalize icon appears below the data display signifying an equalize cycle has been selected. If no battery is connected, the equalize occurs on the next charge cycle to allow the cells to equalize their charge.

The auto-equalize or manual equalize charge can be cleared by pressing the left arrow (=) button again. The next auto equalize charge occurs after the programmed number of charge cycles or day of the week.

## TOBI® PI OPERATION

The control has the ability to communicate with a Tobi® PI battery module. For communication to occur, it must be enabled in the control. This is accomplished by setting the 'BC' parameter.

Setting the BC parameter to 0 disables communication.

Setting the BC parameter to 1 enables normal communication. While the battery is connected to the charger, information is transferred between the charger and the Tobi® PI on the battery including the battery temperature. For the charger to utilize the temperature, the temperature sensor must also be enabled. Temperature compensation is enabled by setting the OK to charge temperature (OT) to a non-zero value. This value indicates the maximum temperature that allows the charge to start. If the battery is above this temperature when it is connected, the control displays the temperature and waits for the battery to cool down before starting the charge.

If the thermal sensor is enabled and is missing or damaged, the control displays an F11 indication when the battery is connected.

The 'Low charge temp' (LT) parameter indicates the temperature at which the charge current is reduced to limit the temperature rise of the battery. The current is reduced proportional to the amount the battery temperature exceeds the limit.

The 'No charge temp' (NT) parameter indicates the temperature at which the charge is terminated. If this temperature is reached during charge, the charger shuts down and displays an F2 indication.

### **Refer to the battery manufacturers recommendations before setting these parameters.**

If the thermal sensor is enabled, the battery voltage milestones on charge (trip point, cutoff, etc.) are compensated by 2.5mV/C per degree F (1.5mV/C per degree F for NiCad) above or below 77 degrees F. If the temperature is below 77 degrees, the voltage is adjusted up and if the temperature is above 77 degrees, the voltage is adjusted down.

Setting the BC parameter to 2 enables normal communication as well as algorithm upload. In addition to the information transferred during normal mode, the charger also uploads and utilizes a charge algorithm from the Tobi® PI on the battery. This can be useful if multiple battery types or AH sizes are used on the same charger. Refer to the Tobi® PI manual for instructions on setting the charge algorithm. Note: If the communication between the charger and Tobi® PI fails, the charger utilizes its own algorithm settings to charge the battery.

## CHARGE INDICATIONS

The following indications are not necessarily a result of a charger problem. They are typically caused by external problems such as AC line, poor battery conditions, connections, etc. If abnormal charge conditions are detected, the charge is terminated, the keypad will be solid RED and the display shows the code:

DISPLAY	DESCRIPTION	POSSIBLE CAUSE
<b>F0 SHORTED CELL</b> ##:##	Battery voltage did not reach 2.00 V/C within 30 minutes. ##:## is the charge time.	<ul style="list-style-type: none"> <li>- Shorted Cell</li> <li>- Open diode</li> <li>- Low Charging amps</li> <li>- Low AC line voltage</li> <li>- Wrong size battery</li> <li>- Battery over-discharged</li> </ul>
<b>F1 SHORTED CELL</b> ##:##	Battery did not reach gassing voltage within the allowable time. ##:## is the charge time.	<ul style="list-style-type: none"> <li>- Shorted Cell</li> <li>- Open diode</li> <li>- Low Charging amps</li> <li>- Low AC line voltage</li> <li>- Wrong size battery</li> <li>- Battery over-discharged</li> </ul>
<b>F2 HOT BATTERY</b> ###°F	Hot battery. The battery exceeded the NT temperature. ###°F is the battery temperature	<ul style="list-style-type: none"> <li>- Battery is overheated</li> <li>- Damaged thermal sensor</li> <li>- Faulty control board</li> </ul>
<b>F3 LOW VOLTS</b> #.## V/C	Low battery voltage, less than 1.60 V/C at start up. #.## V/C is the battery volts per cell.	<ul style="list-style-type: none"> <li>- Wrong size battery</li> <li>- Battery over-discharged</li> <li>- Voltage jumper setting incorrect</li> </ul>
<b>F4 HIGH VOLTS</b> #.## V/C	High battery voltage, more than 2.40 V/C at start up. #.##V/C is the battery volts per cell.	<ul style="list-style-type: none"> <li>- Wrong size battery</li> <li>- Battery fully charged</li> <li>- Voltage jumper setting incorrect</li> </ul>
<b>F5 NO DC CURRENT</b> ### AMPS	No charging current to the battery. ### AMPS is the current at the end of charge.	<ul style="list-style-type: none"> <li>- Faulty AC line contactor</li> <li>- Open diode</li> <li>- Faulty resonant capacitor</li> <li>- Poor battery connections</li> <li>- Open cell</li> <li>- Faulty control board</li> </ul>
<b>F6 CHARGE ERROR</b> ### AMPS	Charger current or voltage not what was requested by control. ### AMPS is the current at the end of charge.	<ul style="list-style-type: none"> <li>- Incorrect control setup</li> <li>- Poor battery connections or open Cell</li> <li>- Faulty HF module (HF chargers)</li> <li>- Faulty firing board or cable (CF chargers)</li> <li>- Faulty control board</li> </ul>
<b>F7 LONG CHARGE</b> ##:##	Long charge, the charger ran longer than the allowed time. ##:## is the charge time.	<ul style="list-style-type: none"> <li>- Open diode</li> <li>- Low Charging amps</li> <li>- Low AC line voltage</li> <li>- Wrong size battery</li> <li>- Battery over-discharged</li> </ul>
<b>F8 CHARGER ON</b> ### AMPS	Charger stayed on when control requested it to shut off. ### AMPS is the charger current.	<ul style="list-style-type: none"> <li>- AC line contactor stuck on</li> <li>- Open shunt sense lead or loose connection</li> <li>- Incorrect control setup</li> <li>- Faulty control board</li> </ul>
<b>F9 BAD KEYPAD</b>	Faulty keypad detected. One or more buttons are stuck on.	<ul style="list-style-type: none"> <li>- Faulty keypad</li> <li>- Faulty control board</li> </ul>
<b>F10 HIGH CURRENT</b> ### AMPS	Charging current exceeds 110% of shunt setting. ### A<PS is the current at the end of charge.	<ul style="list-style-type: none"> <li>- High charging amps or high AC line voltage</li> <li>- Incorrect shunt size</li> <li>- Open shunt sense lead or loose connection</li> <li>- Faulty control board</li> </ul>
<b>F11 TEMP ERROR</b> 255°F	No thermal sensor.	<ul style="list-style-type: none"> <li>- Missing or damaged thermal sensor on Tobi</li> <li>- Thermal sensor enabled when not installed</li> <li>- Faulty Tobi</li> <li>- Faulty control board</li> </ul>

DISPLAY	DESCRIPTION	POSSIBLE CAUSE
M1 BIAS ERROR	HF module bias error.	- Low AC Volts - Bad power supply - Bad HF Module
M2 HIGH DC VOLTS	HF module output DC volts high.	- Battery disconnected while charging - Wrong size battery (too many cells) - Bad HF module
M3 LOW DC VOLTS	HF module output DC volts low.	- Wrong size battery (too few cells) - Shorted battery cell(s) - Bad HF module
M4 HIGH AC VOLTS	HF module input AC volts high.	- High AC line - Bad power supply
M5 LOW AC VOLTS	HF module input AC volts low.	- Low AC line - Bad power supply
M6 OVERTEMP 1	HF module primary side over temperature.	- Fans blocked - Fans not running - Too much dust on heat sink
M7 OVERTEMP 2	HF module secondary side over temperature.	- Fans blocked - Fans not running - Too much dust on heat sink

Note: F3 and F4 clear automatically if the battery voltage falls within acceptable limits. All indications except F8, F9 and F10 can be cleared by disconnecting the battery. For F8, F9, F10 and HF Module Faults, correct the condition that caused the indication and disconnect the battery to clear the indication.

**CAUTION: If F8 indication is showing, and the charger is providing current to the battery, remove AC power from the charger before disconnecting the battery.**

### **F3 (LOW BATTERY) OVERRIDE**

If battery voltage is below 1.6 volts per cell the charger does not start automatically. If this is due to an overly discharged battery of the correct voltage, the F3 indication can be manually overridden by pressing the I/O button while the F3 message (Low Battery) displays.

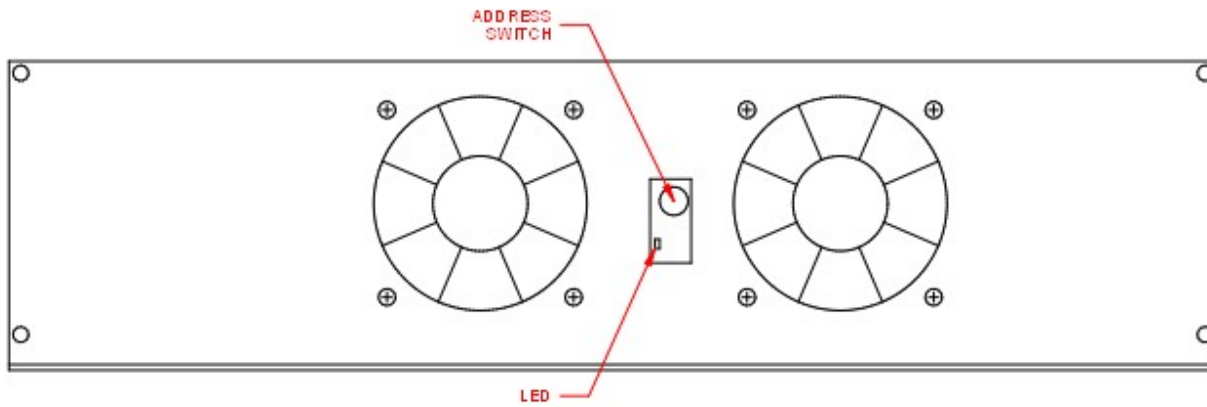

### HF Module Switch and LED Locations

Condition	LED	Possible Cause
Module OK. Not Charging	SOLID GREEN	No Battery Connected Control Interface Cable Disconnected
Module Charging	BLINKING GREEN	Normal Condition
Output Over-Voltage	BLINKING RED	Battery Disconnected While Charging Wrong Size Battery (too many cells)
Output Under-Voltage	PULSING RED	Wrong Size Battery (too few cells) Shorted Battery Cell(s)
Input Over-Voltage	SOLID RED	High AC Line
Input Under-Voltage	OFF	Low AC Line
Temperature Fault	SOLID AMBER	Fans Blocked Fans Not Running Too Much Dust on Heat Sink

## SECTION 3 – TROUBLESHOOTING & GENERAL MAINTENANCE

**Caution:** There are lethal voltages exposed when the charger is energized with the door open. Always disconnect the AC service voltage to the charger before opening the door. The following chart lists the most probable cause of a malfunction.

### SYMPTOMS AND POSSIBLE CAUSES

#### 3.1. No charging current, the control has no display.

##### POSSIBLE CAUSE

- A. Blown AC fuse.
- B. No AC service voltage.
- C. Incorrect AC voltage.
- D. Defective control board.
- E. Defective power supply.

#### 3.2. No charging current, control has a display.

##### POSSIBLE CAUSE

- A. Blown DC fuse.
- B. Open battery cell.
- C. Defective power module.

#### 3.3. AC fuse blows.

##### POSSIBLE CAUSE

- A. Incorrect fuse rating.
- B. Incorrect AC voltage.
- C. Loose connection in AC circuit.
- D. Shorted power module.

#### 3.4. DC fuse blows.

##### POSSIBLE CAUSE

- A. Reversed battery connector.
- B. Incorrect fuse rating.
- C. Shorted power module.

#### 3.5. Excessive water loss in battery.

##### POSSIBLE CAUSE

- A. Charger amp-hour rating exceeds the battery amp-hour rating.
- B. Battery has defective cells.

#### 3.6. Low specific gravity at the end of the charge cycle.

##### POSSIBLE CAUSE

- A. Battery was over-discharged.
- B. Charger amp-hour rating is less than the battery AH rating.
- C. Battery has defective cells.
- D. Battery has been over-watered.

#### 3.7. Charger does not turn off when the control terminates the charge cycle.

##### POSSIBLE CAUSE

- A. Defective control.

#### 3.8 General Maintenance

The charger requires a minimum of maintenance. Connections and terminals should be kept clean and tight. The charger should be periodically cleaned with clean dry compressed air to prevent any excessive dirt build up on components. Care should be taken not to bump or move any adjustments during cleaning. Make sure that both the AC lines and the battery are disconnected before cleaning. The frequency of this type of maintenance depends on the environment in which this unit is installed. If any cabinet sheet metal panels are removed for cleaning, be certain they are properly reinstalled upon completion.

## SECTION 4 – REPLACEABLE PARTS

### 4.1 Ordering Information

The following information must be supplied when ordering a replacement part from your service agent to ensure that the correct part is supplied:

- A. Model or Spec. number of charger (Located on charger data plate)
- B. Serial number of charger (Located on charger data plate)
- C. Description of part

### 4.2 Recommended Spares

The quantity of spares stocked should be increased as the number of chargers increases. The following chart is the minimum quantity recommended per model for multiple charger installations:

<u># OF CHARGERS</u>	<u># OF SPARE PARTS KITS</u>
1-3	1
4-10	2
11-25	3
26-50	4
51-100	5

<u>SCHEMATIC REF</u>	<u>DESCRIPTION</u>	<u>QUAN. USED</u>	<u>QUAN. RECOMMENDED</u>
6	DC FUSE	1	1
2	CONTROL BOARD	1	1
4	HF POWER MODULE	1 TO 4	0
1	POWER SUPPLY	1	0

### 4.3 Spare Parts List

#### Part Number Controls

046-0304 Wireless LCD control

#### Power Supply

049-0539 Power supply, 480VAC  
 049-0561 Power supply, 120/240VAC (also used on 600V with step-down transformer)  
 003-2076 Step-down Transformer, 600V to 120V

#### DC Fuse

011-0243 80A 150VDC Fuse  
 011-0045 150A 150VDC Fuse  
 011-0046 200A 150VDC Fuse  
 011-0047 250A 150VDC Fuse  
 011-0048 300A 150VDC Fuse  
 011-0113 350A 150VDC Fuse  
 011-0049 400A 150VDC Fuse  
 011-0062 500A 150VDC Fuse

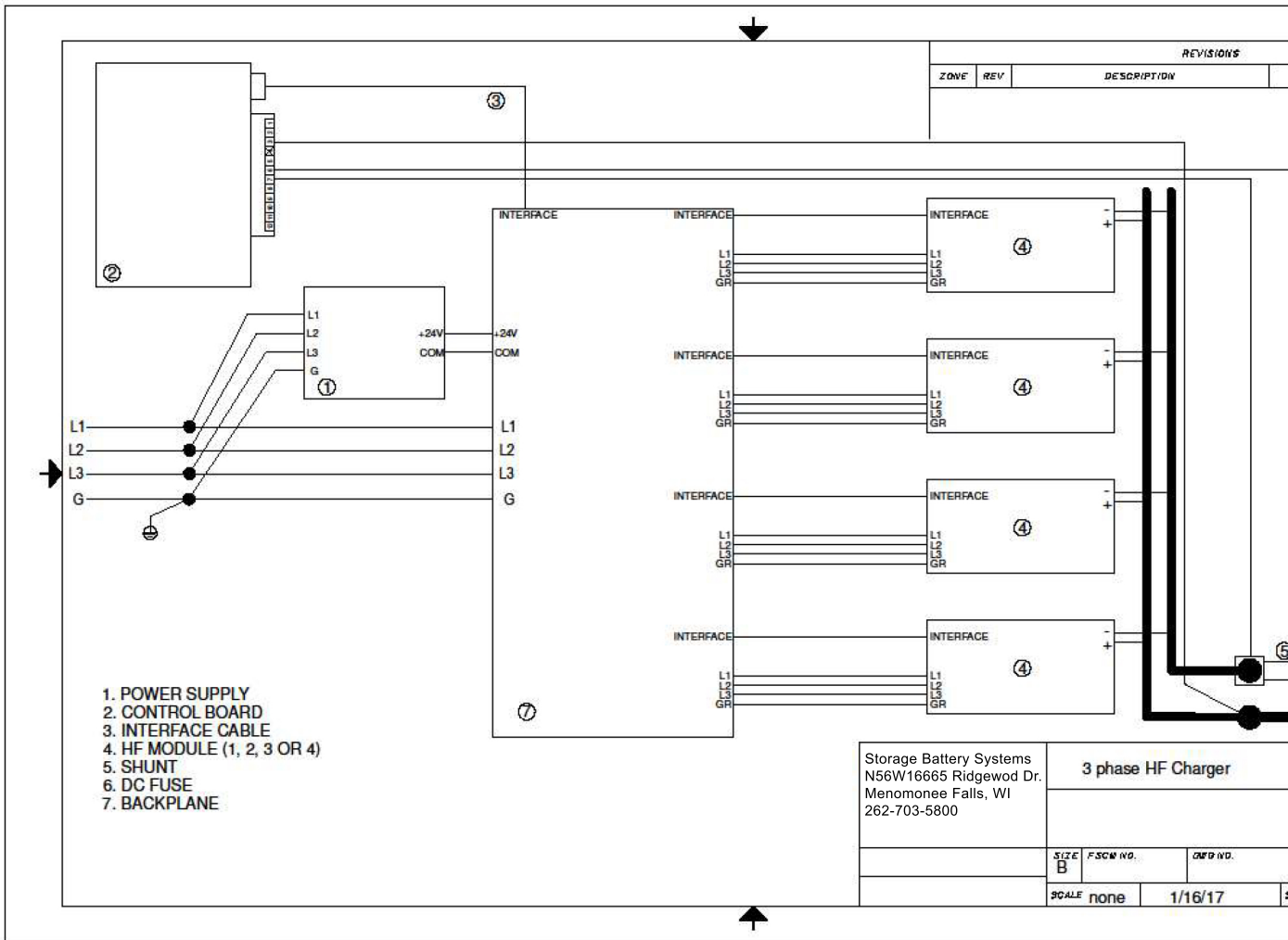



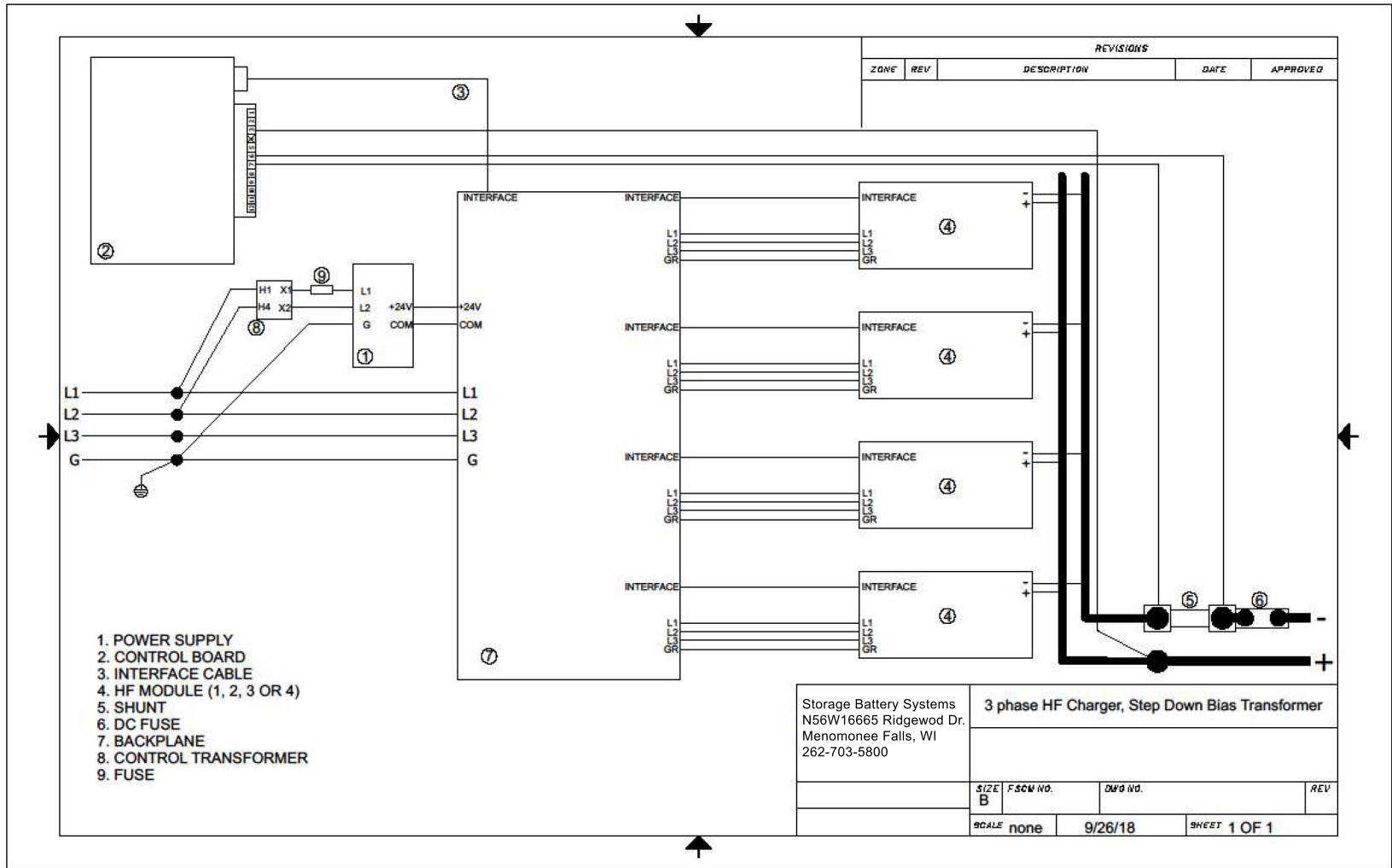

**Storage Battery Systems LLC**  
 N56 W16665 Ridgewood Drive  
 Menomonee Falls, WI 53051

www.sbsbattery.com

800-554-2243

sbs@sbsbattery.com