

Installation and Operation Manual

SBS-Ferro 100

Ferro Resonate Battery Charger



Storage Battery Systems, LLC
N56 W16665 Ridgewood Drive
Menomonee Falls, WI 53051
www.sbsbattery.com
800.554.2243

INDEX

Page	Section	Description
2	-	Safety Instructions
3	1.0	Installation
3	1.1	Receiving
3	1.2	Location
3	1.3	Line Voltage Adjustments
5	1.4	AC Service Requirements
5	1.5	Connecting AC Service to Charger
6	1.6	Grounding the Charger
6	1.7	Battery Connector and Charger Cable
6	1.8	Charging Rate Adjustment
7	2.0	Operation
7	2.1	046-0301 / 046-0303 Controls
13		Programming Instructions
14		Table 1. Parameter List
16		Table 2. Algorithm List
17	3.0	Optional Features
17	4.0	Troubleshooting & Maintenance
19	5.0	Replaceable Parts
19	5.1	Ordering Information
19	5.2	Recommended Spares
20	5.3	Spare Parts List
21	6.0	Schematics

SAFETY INSTRUCTIONS

WARNING

THIS EQUIPMENT CONTAINS LETHAL VOLTAGE LEVELS. INSTALLATION AND SERVICING MUST BE PERFORMED BY QUALIFIED PERSONNEL

IMPORTANT: SAVE THESE INSTRUCTIONS!

READ AND FOLLOW ALL INSTRUCTIONS BEFORE INSTALLING, OPERATING, OR SERVICING CHARGER. ANY DEVIATION CAN CAUSE SERIOUS AND PERMANENT DAMAGE. FAILURE TO FOLLOW THE INSTRUCTIONS VOIDS THE WARRANTY.

1. Install and ground the charger in accordance with the National Electric Code and your local electric code. Failure to properly ground the charger could result in a fatal electric shock.
2. To reduce the risk of fire, install chargers on a surface of non-combustible material, such as concrete, stone, brick or grounded metal.
3. This charger has been designed to only charge flooded, lead-acid batteries. It should not be used for charging other types of flooded batteries or sealed batteries.
4. Connect only batteries of the same number of cells and ampere-hour rating as listed on the charger nameplate. Damage to the battery could occur, particularly if the battery has fewer cells than the rating of the charger.
5. Do not touch uninsulated parts of the output connector or battery terminals. A possibility of serious electrical shock exists.
6. During charge, batteries produce hydrogen gas, which can explode if ignited. Never smoke, use an open flame, or create sparks in the vicinity of the battery. Ventilate well when the battery is in an enclosed space.
7. Do not connect or disconnect the battery plug while the charger is on. Doing so will cause arcing and burning of the connector resulting in charger damage or battery explosion.
8. Lead-acid batteries contain sulfuric acid, which is caustic and can cause chemical burns to the skin. Refer to the battery manufacturer's instructions for safe handling of batteries. Use proper personnel protective equipment. Do not get in eyes, on skin, or on clothing. In cases of contact with eyes, flush immediately with clean water for 15 minutes. Seek medical attention immediately.
9. Do not operate the charger with the door open or with any panels removed. De-energize all AC and DC power connections before servicing the charger.
10. The charger is not for outdoor use. Do not expose the charger to water spray, rain or snow.
11. Do not operate the charger with damaged cables, including cables with exposed conductors or damaged connectors. Replace damaged cables before operation.
12. Do not operate the charger if it has been dropped, received a sharp blow, or otherwise damaged in any way. Call your service representative.

SECTION 1 - INSTALLATION

1.1. Receiving

Immediately upon receipt of the charger, check it against the shipping invoice to ensure the shipment is complete and undamaged.

Examine the outside of the packing for signs of rough handling before accepting the charger from the carrier.

If there is evidence of damage, the receipt should be signed, and both copies (carrier's and receiving copies) marked "Shipment Received Damaged". The carrier's representative should be called immediately and asked to make a "Carrier's Damage Report".

If concealed damage is later detected, the carrier should be called and requested to make a "Carrier's Inspection for Concealed Damage Report".

After inspection by the carrier, arrangements should be made with the charger representative to have the charger repaired before placing it in service.

When contacting your charger representative for assistance on a damage claim or shipment error, provide the Model, and Serial Number of the charger, and a full description of the damage or error.

It is good practice to move the charger to the installation site before uncrating. When using bars, hammers, etc. for uncrating, use care to avoid damage to the charger.

WARNING: To reduce the risk of fire, install the battery charger on a non-combustible surface such as concrete, stone, brick, or steel. DO NOT operate the charger on its shipping skid materials.

1.2. Location

For the best operating conditions and longest life, take care in selecting an installation site. Avoid locations exposed to high humidity, temperature extremes or dust. Moisture condensing on machine parts and electrical components can cause corrosion, which seriously affects operation, efficiency and life. All units are designed for floor mounting. Standard cases may be stack-mounted if required, up to 3 high. If so, optional stacking brackets are required and available. Consult factory.

Dust and dirt will also decrease heat radiation from heat-generating components, such as transformers and diodes. This will result in higher operating temperatures and shorter life. Adequate air circulation is needed at all times to ensure proper operation. Provide a minimum of 6 inches of free air space at the sides and rear of the charger. The front of the charger must remain unobstructed for serviceability.

1.3. Line Voltage Adjustments

All chargers are shipped with the AC line voltage jumper wires set for the AC voltage specified on the purchase order. Before connecting the charger to the AC service, it should be verified that the internal AC voltage connections match the available AC service voltage. If necessary, change the AC voltage jumper wires shown in Figs. 1.3.1 through 1.3.3.

NOTE: For 50 Hz. Single or three phase fixed voltage chargers, there are no adjustments.

CAUTION: It will be necessary in most cases to change the AC fuses when the AC voltage jumpers are changed. Refer to the fuse chart on the inside door of the charger for the correct fuse rating.

NOTE: When a 120/208/240 AC input unit is set for 120VAC a fuse neutral (brass tube) is required in the Line 2 (neutral) fuse position.

Fig. 1.3.1.
 A.C. Voltage Adjustments
 1 Ø 60Hz. (120/208/240)
 "A" Voltage Code

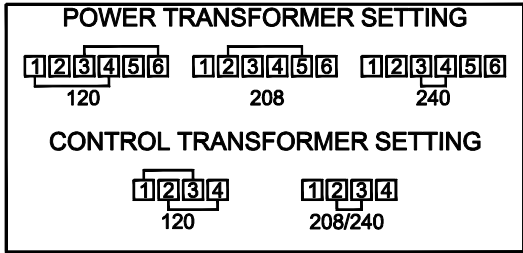

Fig. 1.3.2.
 A.C. Voltage Adjustments
 1Ø & 3Ø 60Hz. (208/240/480)
 "B" Voltage Code

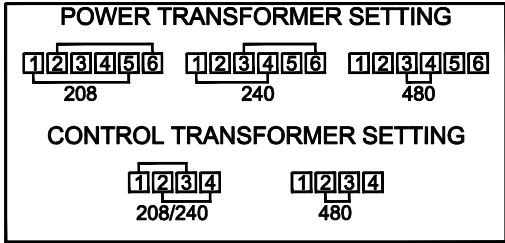
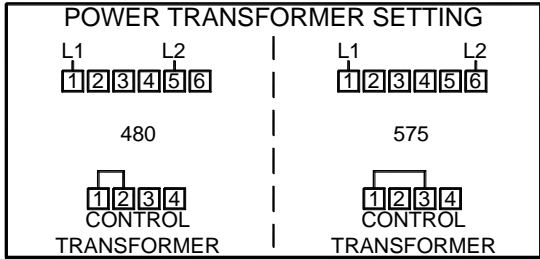

Fig.1.3.3.
 A.C. Voltage Adjustments
 3 Ø 60Hz. (480/575)
 "K" Voltage Code



1.4. AC Service Requirements

Follow local code requirements if they are different than the instructions in this manual. After checking the transformer connections as described in Paragraph 1.3, refer to Table 1-1, to determine the correct ratings for the AC cable, AC fuses, and AC service disconnect switch for the line amperes as listed on the nameplate of the charger for the available AC voltage

Line Amperes	Disconnect Switch	Fuse Size Amps
000.0 - 02.5	30A	05
003.0 - 04.5	30A	07
005.0 - 07.5	30A	10
008.0 - 11.0	30A	15
011.5 - 15.5	30A	20
016.0 - 18.0	30A	25
018.5 - 22.0	30A	30
022.5 - 27.0	60A	35
027.5 - 32.0	60A	40
032.5 - 40.0	60A	50
040.5 - 48.0	60A	60
048.5 - 64.0	80A	80
065.0 - 80.0	100A	100
081.0 - 95.0	125A	125

For voltages up to 240, use a 240 volt disconnect switch.

For voltages greater than 240 to 600, use a 600 volt disconnect switch.

- Two conductors and ground wire required for single phase.
- Three conductors and ground wire required for three-phase

1.5. Connecting AC Service to the Charger

1.5.1 Single-Phase Models

Connect the AC service to the L1 and L2 terminals located at the end of the AC fuse block.

Note: If the charger has been ordered with an AC input door-mounted disconnect switch, the AC input wires will be connected to the L1 and L3 terminals at the top of the switch body.

1.5.2 Three-Phase Models

Connect the AC service to the L1, L2 and L3 terminals located at the end of the AC fuse block.

Note: If the charger has been ordered with an AC input door-mounted disconnect switch, the AC input wires will be connected to the L1, L2 and L3 terminals at the top of the switch body.

1.6 Grounding the Charger

The charger must be grounded to the AC system ground for personnel safety.

The green ground wire in the AC input wiring must be connected to the charger ground stud (identified by a green dot and ground symbol).

1.7 Battery Connector and Charging Cable

Verify that the connectors on both the battery and the charger are attached so that the positive output terminal of the charger is connected to the positive battery terminal.

**CAUTION: If the polarity is reversed, the DC fuse will blow.
If in doubt, check the polarity with a DC voltmeter.**

1.8 Charging Rate Adjustment

Note: Charging rate adjustments may be necessary to compensate for locations of extreme AC line variation or may be used to tailor the charger output for aging batteries.

The charging rate has been set at the factory; therefore, field adjustment should not be necessary.

If there appears to be a charging rate problem, refer to the troubleshooting chart, Section 4.

If it is necessary to either increase or decrease the charging rate, a rate adjustment terminal block is provided on the top rear of the transformer mounting bracket.

Change only one step at a time and observe the effect on the battery before making a second change.

The charging rate is increased by moving to the next higher tap setting in Table 1-2.

The charging rate is decreased by moving to the next lower tap setting.

No adjustments should be made without consulting the factory.

TABLE 1-2		
CHARGING RATE ADJUSTMENTS		
CONNECT RED JUMPER WIRE TO	CONNECT BLACK WIRE TO	OUTPUT
9	12	HIGHEST
9	11	
9	10	
9	8	NORMAL
12	11	
12	10	
12	9	LOWEST

SECTION 2 - OPERATION

046-0301 / 046-0303 Controls

The charger utilizes a standard ferro-resonant transformer, which provides isolation from the AC service line and regulates the charging current. The transformer output is connected to a full-wave bridge of silicon diodes, which provides DC charging current to the battery.

The starting charge amps and length of time required for a charge vary depending on the charger model. See the data plate on the charger for information.

Feature Summary

- Charges flooded lead-acid batteries.
- Automatic start when battery is connected or manual start (if selected).
- Automatic stop when charge is finished.
- Fully charges partially discharged batteries without overcharging.
- Dead battery 'jump start' for overly-discharged batteries.
- Equalize charge by user request or automatic equalize every 7 charges (if selected).
- Automatic refresh charging every 12 hours (if selected).
- Automatic shut-down if battery starts to overheat.
- Automatically resumes charge after a power failure (if auto-start selected).
- Displays charging amps during the charge cycle.
- End voltage, end current, amp-hours returned, and run time can be displayed at the end of charge or after disconnecting the battery.
- Delayed start adjustable from 0 to 12 hours (if auto-start selected).
- Time of date start and peak energy period block out (303 only)
- Displays fault codes if a fault occurs during charging.
- Cool down timer that shows elapsed time after the charge is complete (if selected).
- Communicates with Tobi on the battery for temperature compensation or algorithm upload (303 only)
- Wireless communication for setup and data retrieval (303 only)

Operation

The control is used in ferro-resonant taper chargers to provide fully automatic battery charging. The control has a charging profile that handles standard flooded lead-acid batteries. The charging profile, or algorithm, uniquely monitors the output current and voltage to optimally charge the battery, based on battery manufacturer's recommendations.

The standard charging profile for flooded lead-acid batteries has 2 phases. During phase 1 the battery is charged at high current until the battery is 80% charged. Then phase 1 terminates and phase 2 begins. As the battery voltage rises during phase 2, charging current tapers down toward the finish rate current and the battery voltage starts to flatten out. Phase 2 ends and the charge is terminated when the battery voltage no longer changes. This termination method is called 'dv/dt-di/dt'.

The control offers several safeguards to protect the battery. If a wrong voltage battery is connected, the charger does not start and a Low-Battery-Voltage (F3) or High-Battery-Voltage (F4) fault message is displayed. While charging, if the battery voltage exceeds a profile-specific cut-off value, the charge terminates with an End-On-Voltage warning message (EnU followed by the end voltage in v/c).

Normal Daily Charge

When no battery is connected, the keypad will be flashing GREEN and the display will show 'CONNECT BATTERY'. With the auto-start feature enabled, connecting a battery to the charger will cause it to begin a charge cycle. The charger will first perform a self-diagnostic test to verify the control is working properly. During this time a lamp test is performed causing all display segments and indicators to light. This allows the operator to observe any defective segments or indicators. When the self-diagnostic is complete, the charge starts if no delay is set, and the keypad will be flashing AMBER. The display shows the charging amps to indicate the charger is in phase 1 of the charge cycle. If auto start is disabled, the display shows 'OFF'. Press the I/O button to manually start the charge.

When the battery is 80% charged, the charger starts phase 2 of the charge cycle.

When a charge is finished, the charger automatically turns off. The keypad will be solid GREEN.

Disconnecting the Battery

Warning: Risk of explosion. Do not disconnect the battery while the charger is running. Hydrogen gas produced by the battery during charging can be ignited by arcing that occurs when the battery cable is disconnected.

If the battery must be disconnected before the end of the charge cycle, the charger should be turned off first. Press the center I/O button and verify the Charging icon goes out. The 3-digit display will show 'OFF'. The battery may then be safely disconnected. If the Battery Ready icon is lit, the battery may be disconnected at any time.

Equalize Charge

Over time batteries can develop inequalities in cell charge. This can lower the effective capacity of the battery and shorten life. An equalizing charge re-balances the charge in the battery cells. Perform an equalize charge if any of the following conditions exist:

1. On flooded batteries, the specific gravity of any cell at the end of charge is 20 points less than the average of all the cells.
2. The on-charge voltage of any cell at the end of charge is 20 millivolts less than the average of all the cells.
3. The battery has been stored for 30 days.

The control can perform an equalize automatically every 7 charge cycles if auto equalize is enabled. Normal equalize consists of an additional 3-hour charge time at the end of a normal charge cycle. The control can also perform an equalize charge when requested manually. First connect the battery and allow the charge to start normally. Then press the left button "=" to select an Equalize charge, the equalize icon will light. The charge time will be extended by 3 hours to allow the cells to equalize their charge.

The auto-equalize or manual equalize cycle can be cleared by pressing the left button, "=", while in the normal charge cycle. The 'Equalize' icon will turn off. Note that once an auto-equalize has been queued in the control, the control will attempt to perform the auto-equalize every time a battery is connected until an equalize charge has been completed.

If auto equalize is not desired, contact your battery/charger service provider for control setup change.

TOBI® PI Operation (303 Only)

The control can communicate with a Tobi® PI battery module. For communication to occur, it must be enabled in the control. This is accomplished by setting the 'BC' parameter (see table 1).

Setting the BC parameter to 0 disables communication.

Setting the BC parameter to 1 enables normal communication. While the battery is connected to the charger, information is transferred between the charger and the Tobi® PI on the battery including the battery temperature. For the charger to utilize the temperature, the temperature sensor must also be enabled. Temperature compensation is enabled by setting the OK to charge temperature (OT) to a non-zero value. This value indicates the maximum temperature that allows the charge to start. If the battery is above this temperature when it is connected, the control displays the temperature and waits for the battery to cool down before starting the charge.

If the thermal sensor is enabled and is missing or damaged, the control displays an F11 indication when the battery is connected.

The 'Low charge temp' (LT) parameter indicates the temperature at which the charge current is reduced to limit the temperature rise of the battery. The current is reduced proportional to the amount the battery temperature exceeds the limit.

The 'No charge temp' (NT) parameter indicates the temperature at which the charge is terminated. If this temperature is reached during charge, the charger shuts down and displays an F2 indication.

Refer to the battery manufacturers recommendations before setting these parameters.

If the thermal sensor is enabled, the battery voltage milestones on charge (trip point, cutoff, etc.) are compensated by 2.5mV/C per degree F (1.5mV/C per degree F for NiCad) above or below 77 degrees F. If the temperature is below 77 degrees, the voltage is adjusted up and if the temperature is above 77 degrees, the voltage is adjusted down.

Setting the BC parameter to 2 enables normal communication as well as algorithm upload. In addition to the information transferred during normal mode, the charger also uploads and utilizes a charge algorithm from the Tobi® PI on the battery. This can be useful if multiple battery types or AH sizes are used on the same charger. Refer to the Tobi® PI manual for instructions on setting the charge algorithm. Note: If the communication between the charger and Tobi® PI fails, the charger utilizes its own algorithm settings to charge the battery.

Delayed Start

The delayed-start feature allows the operator to delay starting the charge cycle. This might be desired to reduce peak energy surcharges if the charger were ready to start during a peak energy period. The delay time could be set to keep the charger from starting until after the peak period ends.

The control has a delay icon that will light when the delay is triggered. See the control parameters and settings chart to program the delay start.

If the auto-start feature is disabled, the delayed start is automatically set to 0 and is disabled. The delayed start time cannot be set.

Auto-Refresh Charge

The control can provide an auto-refresh charge periodically as long as the battery remains connected to the charger. If AC power is lost during the wait period, the control will resume from where it left off after power is restored. During the auto-refresh charge, the amp-hours and charge time will be added to the original charge.

Time of Day Start (303 Control Only)

The time-of-day start feature allows the operator to delay the start of charge until a particular time of day. This might be desired to reduce peak energy surcharges if the charger were ready to start during a peak energy period. The time-of-day start could be set to keep the charger from starting until after the peak period ends.

Setting Time of Day (303 Control Only)

To use the Time of Day Start feature, the current time of day must be set correctly. See control programming instructions.

Emergency Stop

To manually terminate the charge cycle, press the center 'I/O' button. The charge will immediately stop. The Charge State display will then show 'OFF'. Pressing 'I/O' while the DATA display shows 'OFF' causes the charge to resume.

Battery Cool Down Time

A time can be set to allow a battery to cool down after being charged. While the charger is in the cool down period, the Data area will display the timer in Military time, the Units will display as Time. The Cool down timer can be set to count down or count up the set time. See programming instructions.

Charge Indications

The following indications are not necessarily a result of a charger problem. They are typically caused by external problems such as AC line, poor battery conditions, connections, etc. If abnormal charge conditions are detected, the charge is terminated, the keypad will be solid RED and the display shows the code:

DISPLAY	FAULT DESCRIPTION
F0 #:##	Possible shorted cell or low charging amps. Battery voltage did not reach 2.0V/C (1.2V/C for Ni-Cad) within 30 minutes. #:## is the charge time
F1 #:##	Possible shorted cell or low charging amps. Battery did not reach gassing voltage during charge phase 1. #:## is the charge time.
F2 ### °F	Hot battery. Battery exceeded the No Charge Temp. ### is battery temperature.
F3 ### V/C	Low battery voltage, less than 1.6V/C at start up. ### is the volts per cell when battery was connected.
F4 ### V/C	High battery voltage, more than 2.4V/C at start up. ### is the volts per cell when battery was connected.
F5 ### AMPS	No charging current to the battery.
F6 ### AMPS	Charger current/voltage not what was set by control. N/A for ferro-resonant charger.
F7 #:##	Long charge, the charger ran longer than the allotted time. #:## is the charge time.
F8 ### AMPS	Charger stayed on when control requested it shut off. ### is the charger current.
F9	Bad keypad. One or more buttons are stuck.
F10 ### AMPS	Charger current exceeded 110% of the shunt rating. ### was the charger current.
F11 255 °F	Faulty thermistor. Bad thermistor on the Tobi, no Tobi installed, or no communication between the charger and Tobi.

F3 (Low Battery) Override

If battery voltage is below 1.6 volts per cell the charger will not start automatically. If this is due to an overly discharged battery of the correct voltage, the F3 fault can be manually overridden by pressing the center I/O button while the F3 message (Low Battery) displays.

46-301/303 Control Reference Guide

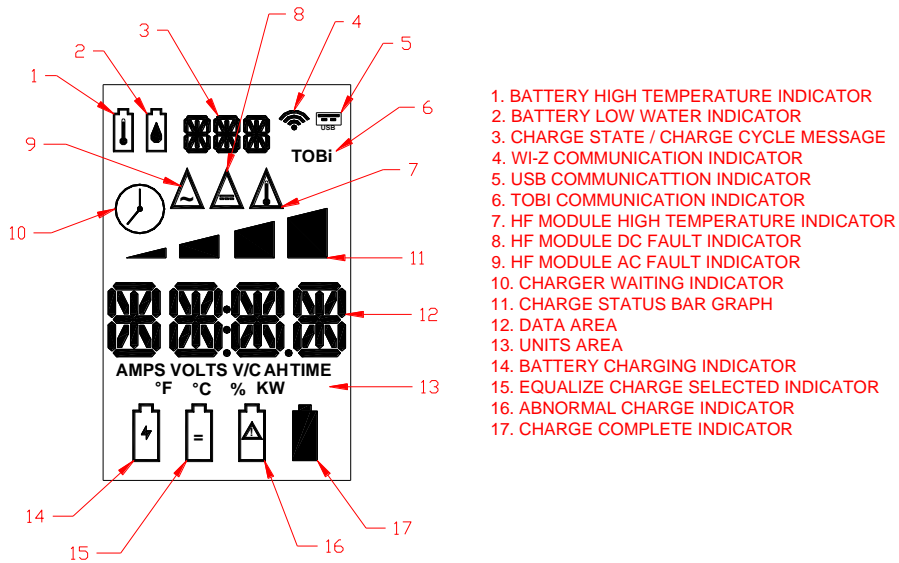

1. BATTERY HIGH TEMPERATURE INDICATOR
2. BATTERY LOW WATER INDICATOR
3. CHARGE STATE / CHARGE CYCLE MESSAGE
4. WI-Z COMMUNICATION INDICATOR
5. USB COMMUNICATION INDICATOR
6. TOBi COMMUNICATION INDICATOR
7. HF MODULE HIGH TEMPERATURE INDICATOR
8. HF MODULE DC FAULT INDICATOR
9. HF MODULE AC FAULT INDICATOR
10. CHARGER WAITING INDICATOR
11. CHARGE STATUS BAR GRAPH
12. DATA AREA
13. UNITS AREA
14. BATTERY CHARGING INDICATOR
15. EQUALIZE CHARGE SELECTED INDICATOR
16. ABNORMAL CHARGE INDICATOR
17. CHARGE COMPLETE INDICATOR

Display Icons

1. The battery high temperature indicator will be displayed when a battery connected to the charger having a Tobi PI installed is above the OK to charge temperature stored in the Tobi (303 control only).
2. The battery low water indicator will be displayed when a battery connected to the charger having a Tobi PI installed detects low water and the charge cycle is complete (303 control only).
3. The charge state/charge cycle message area is used to indicate the charger state during normal operation. It will display the charge cycle number when reviewing charge history (301/303).
4. The Wi-Z communication indicator will be displayed when the charger is connected to a Wi-Z network and communicating with the coordinator (303 control only).
5. Not Used.
6. The TOBi communication indicator will be displayed when a battery connected to the charger having a Tobi PI installed is communicating with the charger (303 control only).
7. The HF module high temperature indicator will be displayed when an HF module in the charger has exceeded the safe operating temperature (303 control only).
8. The HF module DC fault indicator will be displayed when an HF module in the charger has detected a fault on the DC output (303 control only).
9. The HF module AC fault indicator will be displayed when an HF module in the charger has detected a fault on the AC input (303 control only).
10. The charger waiting indicator will be displayed when the charger is in a wait state (301/303).
11. The charge status bar graph displays the status of the charge cycle (301/303).
12. The data area will display charging amps during a charge cycle. It will display additional charge data when reviewing charge parameters and will display data for previous charge cycles when reviewing history (301/303).
13. The units area will display the units for the value shown in the data area (301/303).
14. The battery charging indicator will be displayed when the charger is on and charging (301/303).
15. The equalize charge selected indicator will be displayed when an equalize cycle has been selected for the current charge cycle (301/303).
16. The abnormal charge indicator will be displayed when the charger detects an abnormal charge condition (301/303).
17. The charge complete indicator will be displayed when the charge cycle is complete (301/303).

Keypad

The keypad has 4 directional buttons, UP(+), DOWN(-), LEFT(=), RIGHT(info), and a center On/Off (I/O) button.

- To terminate a charge cycle, press the I/O button
- To select/unselect an equalize cycle for the current charge, press the LEFT(=) button
- To view additional charge data during a charge cycle, press the RIGHT(info) button. The data area of the display will show the data and the units area will display the units for the parameter being displayed. Press RIGHT(info) again for additional data. After 10 seconds, the display will return to the normal display of amps.
- To view charge history, press the UP(+) or DOWN(-) buttons to display a previous charge cycle. The charge cycle number will be displayed in the charge cycle message area and the data will be displayed in the data area along with the units in the units area. Cycle 1 is the most recent and 100 is the oldest. To view additional data for the charge cycle, press the RIGHT(info) button. The data area of the display will show the data and the units area will display the units for the parameter being displayed. Press RIGHT(info) again for additional data. After 10 seconds, the display will return to the normal display of amps.

LED Indication

The keypad center I/O button has a multi-color LED backlight to indicate charger status.

LED COLOR	STATUS
Flashing GREEN	Charger ready for battery
Solid GREEN	Charge complete
Flashing AMBER	Charging
Solid AMBER	Battery connected. Charger OFF
Solid RED	Abnormal charge detected

46-301/303 Programming Instructions

- **To enter programming mode:** press and hold the RIGHT arrow button. While holding the RIGHT arrow button, press and release the UP arrow button, then press and release the DOWN arrow button. Finally release the RIGHT arrow button. The parameter name will be flashing in the top center of the display. The value for the parameter will be shown in the center of the display with the units below.
- **To change the parameter to edit:** With the parameter name flashing, press the UP or DOWN arrow button. The parameter name in the top center of the display will change and the value and units will be updated for the parameter.
- **To change the value of a parameter:** With the parameter name flashing, press the RIGHT or LEFT arrow button. The first digit of the parameter value will be flashing. To change the digit to edit, press the RIGHT or LEFT arrow button (note: digits above the max allowed value for a parameter cannot be selected). To change the value of the digit that is flashing, press the UP or DOWN arrow button. Values above or below the valid range for the parameter, will automatically be limited to the maximum and minimum values, or will set to an alternate value for the parameter. Refer to table 1 for more information.
- **To save the value of a parameter:** When the desired value for the parameter is showing, press the center I/O button. The new value will automatically be saved and the parameter name will be flashing. To change additional parameters, use the UP and DOWN arrows to select.
- **To exit programming mode:** When all programming changes have been made, press the center I/O button. The control will return to the normal display.

Example: Setting the Clock

- Enter programming mode by holding the RIGHT arrow and then pressing and releasing UP and then DOWN.
- The first parameter (AL) will be flashing in the top center of the display. Press the DOWN arrow several times until the parameter TD (time of day) is flashing.
- Press the LEFT arrow. The RIGHT most digit of the time will flash. Press the UP or DOWN arrow button to change the value of the RIGHT most digit.
- Press the LEFT arrow button. The second digit will be flashing. Press the UP or DOWN arrow buttons to change the value of the digit.
- Press the LEFT arrow button. The third digit will be flashing. Press the UP or DOWN arrow buttons to change the value of the digit.
- Press the LEFT arrow button. The fourth digit will be flashing. Press the UP or DOWN arrow buttons to change the value of the digit.
- When the correct time is shown, press the I/O button. The parameter TD will be flashing in the top center of the display.
- Press the I/O button again to exit programming mode.

Table 1. Parameter List

Parameter	Description	Range	Control	Notes
AL	Charge Algorithm	1-24	301/303	1
BS	Battery AH Size	100-2200 AH	301/303	
VR	Battery Voltage Rating	0-999 V (0 used for multi-volt)	301/303	
SR	Shunt Rating	50-600 A	301/303	
BC	Battery Communication	0: off 1: on 2: Upload algorithm	303	
BS2	Battery AH Size 2 (multi-volt)	0-2200 AH	303	
BS3	Battery AH Size 3 (multi-volt)	0-2200 AH	303	
AS	Auto Start	0: manual start 1: auto start 2: auto start on AC	301/303	
CR	Cable Resistance	0-25 mΩ	301/303	
TP	Trip Point	1.20-4.25 V/C	301/303	2
CV	Cutoff Voltage	1.40-4.50 V/C	301/303	2
TS	Time of Day Start	0:00-23:59 99:99 (disable)	303	
CT	Cool down Time	0:00-24:00	301/303	
TU	Cool down Count UP/DOWN	0: count down 1: count up	301/303	
EM	Equalize Mode	0: equalize disabled 1: equalize enabled	301/303	2
EI	Equalize Current	0.1-10.0 A/100AH	303	2
EC	Equalize by Cycles	0-100	301/303	2
ED	Equalize by Day	0: disable 1-7: Sunday-Saturday	303	2
DE	Delay Equalize	0:00-24:00	301/303	2
ET	Equalize Time (duration)	0:00-24:00	301/303	2
OT	OK to Charge Temp	0-185 °F (0 disables)	303	2
LT	Low Charge Temp	0-185 °F	303	2
NT	No Charge Temp	0-185 °F	303	2
PS	Energy Management Peak Start Time	0:00-23:59 99:99 (disable)	303	
EP	Energy Management Peak End Time	0:00-23:59 99:99 (disable)	303	

TD	Time of Day (Clock)	0:00-23:59	303	
MO	Month	1-12	303	
DY	Day	1-31	303	
YR	Year	0-99	303	
DS	Delay Start	0:00-24:00	301/303	
SA	Set Amps	0.0-100.0 A/100AH	303	3
SV	Set Volts	0.0-999.9 V	303	3
ST	Set Time	0:00-99:99	303	3
AR	Auto Refresh	0:00-72:00	301/303	
MP	Max Power	0.1-100.0 KW	303	

Notes:

1. The Algorithm is set for the particular charger and battery type. If you are unsure of which algorithm to use, consult factory before setting.
2. These parameters are part of the algorithm. Any changes made to these are overwritten whenever the algorithm parameter is set.
3. These parameters are only used for certain algorithms. Consult the factory before changing any unfamiliar parameters.

Table 2. Algorithm List

<u>Algorithm</u>	<u>Battery Type</u>	<u>Charger Type</u>	<u>Algorithm Type</u>	<u>Description</u>
2	Flooded Lead-Acid	Ferro-Resonant	Normal DVDT	Phase 1: Full output until 2.38 v/c. Phase 2: Full output until dvdt. Phase 3: not used. Phase 4: not used.
3	Flooded Lead-Acid	Ferro-Resonant	Hysteresis	Phase 1: Full output until 2.38 v/c. Phase 2: Full output until dvdt. Phase 3: Charger off until voltage drops to the <i>hysteresis point</i> , then reverts to phase 1. Phase 4: not used. *Additional Settings: <i>hysteresis point</i> = SV parameter.
5	Champion Sealed	Ferro-Resonant	Normal DVDT	Phase 1: Full output until 2.37 v/c. Phase 2: Full output until dvdt or 2.52v/c. Phase 3: not used. Phase 4: not used.
16	Flooded Lead-Acid	Ferro-Resonant	Opportunity Charge	Phase 1: Full output until 2.38 v/c. Phase 2: Off until the time of day reaches the <i>set time</i> . Phase 3: Full output until dvdt. Phase 4: not used. *Additional Settings: <i>set time</i> = ST parameter.

*** Refer to table 1 for information on how to program Additional Settings.**

SECTION 3 - OPTIONAL FEATURES

3.1 Charger Stand

The charger stand is a metal frame that is designed to bolt the charger cabinet on top of it. It raises the cabinet up to the operator's level, rather than having the cabinet sitting on the floor.

SECTION 4 – TROUBLESHOOTING & GENERAL MAINTENANCE

Caution: There are lethal voltages exposed when the charger is energized with the door open. Always disconnect the AC service voltage to the charger before opening the door. The following chart lists the most probable cause of a malfunction.

SYMPTOMS AND POSSIBLE CAUSES

4.1. No charging current, the control has no display, contactor does not operate.

POSSIBLE CAUSE

- A. Blown AC fuse.
- B. No AC service voltage.
- C. Incorrect AC voltage.
- D. Control transformer output fuse blown.
- E. Defective control transformer.
- F. Defective control board.

4.2. No charging current, control has a display.

POSSIBLE CAUSE

- A. Blown DC fuse.
- B. Defective ammeter.
- C. Open battery cell.
- D. Defective diode.
- E. Defective capacitor.
- F. Shorted power transformer secondary.

4.3. AC fuse blows.

POSSIBLE CAUSE

- A. Incorrect fuse rating.
- B. Incorrect AC voltage.
- C. Fuse Block holding clips loose.
- D. Shorted transformer winding.

4.4. DC fuse blows.

POSSIBLE CAUSE

- A. Reversed battery connector.
- B. Incorrect fuse rating.
- C. Shorted diode.

4.5. Excessive water loss in battery.

POSSIBLE CAUSE

- A. Charging rate is too high. See Section 1.8.
- B. Charger amp-hour rating exceeds the battery amp-hour rating.
- C. Battery has defective cells.

4.6. Low specific gravity at the end of the charge cycle.

POSSIBLE CAUSE

- A. Battery was over-discharged.
- B. Charger amp-hour rating is less than the battery AH rating.
- C. Defective open diode.
- D. Charging rate is too low. See Section 1.8.
- E. Battery has defective cells.
- F. Battery has been over-watered.

4.7. Charger does not turn off when the control terminates the charge cycle.

POSSIBLE CAUSE

- A. Defective control.
- B. AC contactor has welded contacts.

4.8. General Maintenance

The charger requires a minimum of maintenance. Connections and terminals should be kept clean and tight. The charger should be periodically cleaned with an air hose to prevent any excessive dirt build up on components. Care should be taken not to bump or move any adjustments during cleaning. Make sure that both the AC lines and the battery are disconnected before cleaning. The frequency of this type of maintenance depends on the environment in which this unit is installed. If any cabinet sheet metal panels are removed for cleaning, be certain they are properly reinstalled upon completion.

SECTION 5 – REPLACEABLE PARTS

5.1 Ordering Information

The following information must be supplied when ordering a replacement part from your service agent to ensure that the correct part is supplied:

- A. Model or Spec. number of charger (Located on charger data plate)
- B. Serial number of charger (Located on charger data plate)
- C. Schematic reference symbol or part
- D. Description of part

5.2 Recommended Spares

The quantity of spares stocked should be increased as the number of chargers increases.

The following chart is the minimum quantity recommended per model for multiple charger installations:

<u># OF CHARGERS</u>	<u># OF SPARE PARTS KITS</u>
1-3	1
4-10	2
11-25	3
26-50	4
51-100	5

<u>SCHEMATIC REF SYMBOL</u>	<u>DESCRIPTION</u>	<u>QUAN. USED</u>	<u>QUANTITY RECOMMENDED</u>
ACF	AC FUSE, 1 PH.	2	4
ACF	AC FUSE, 3 PH.	3	6
DCF	DC FUSE	1	2
CONTROL	CONTROL BOARD	1	1
AK	A.C. CONTACTOR	1	1
SD1,SD2	SILICON DIODE, 1 PH.	2	2
SD1-SD6	SILICON DIODE, 3 PH.	6	3
TP	TRANSFORMER, 1 PH.	1	0
TP	TRANSFORMER, 3 PH	3	0
C	CAPACITOR	VARIES	1
CT	CONTROL TRANSFORMER	1	1

5.3 Spare Parts List

<u>Part Number</u>	<u>Description</u>
<u>Condensers</u>	
008-0002	2 MFD 440 Volt
008-0004	4 MFD 440 Volt
008-0006	6 MFD 440 Volt
008-0008	8 MFD 440 Volt
008-0010	10 MFD 440 Volt
008-0012	12.5 MFD 440 Volt
008-0015	15 MFD 440 Volt
008-0017	17.5 MFD 440 Volt
008-0020	20 MFD 440 Volt
008-0030	30 MFD 440 Volt
008-0040	40 MFD 440 Volt
<u>Diodes</u>	
024-0001	70 A 600 Volt
024-0003	150 A 600 Volt
024-0152	Rectifier Assembly 1ph 108A
024-0153	Rectifier Assembly 1ph 135A
024-0154	Rectifier Assembly 1ph 156A
024-0156	Rectifier Assembly 3ph 108A
024-0157	Rectifier Assembly 3ph 135A
024-0158	Rectifier Assembly 3ph 156A
<u>Contactors</u>	
A09-0020	30 Amp 3 Pole
A09-0021	30 Amp 2 Pole
A09-0049	60 Amp 3 Pole
<u>Controls</u>	
P46-0301	LCD STANDARD CONTROL
P46-0302	LCD WIRELESS CONTROL
<u>Control Transformers</u>	
A03-1210	240/480P, 24S, 50 VA
A03-1211	120/240P, 24S, 50 VA
A03-1213	480/600P, 24S, 50 VA
<u>DC Fuses Flat</u>	
011-0054	80 Amp, 130 Volt
011-0055	100 Amp, 130 Volt
011-0056	150 Amp, 130 Volt
011-0057	200 Amp, 130 Volt
011-0058	250 Amp, 130 Volt
011-0059	300 Amp, 130 Volt
011-0060	400 Amp, 130 Volt

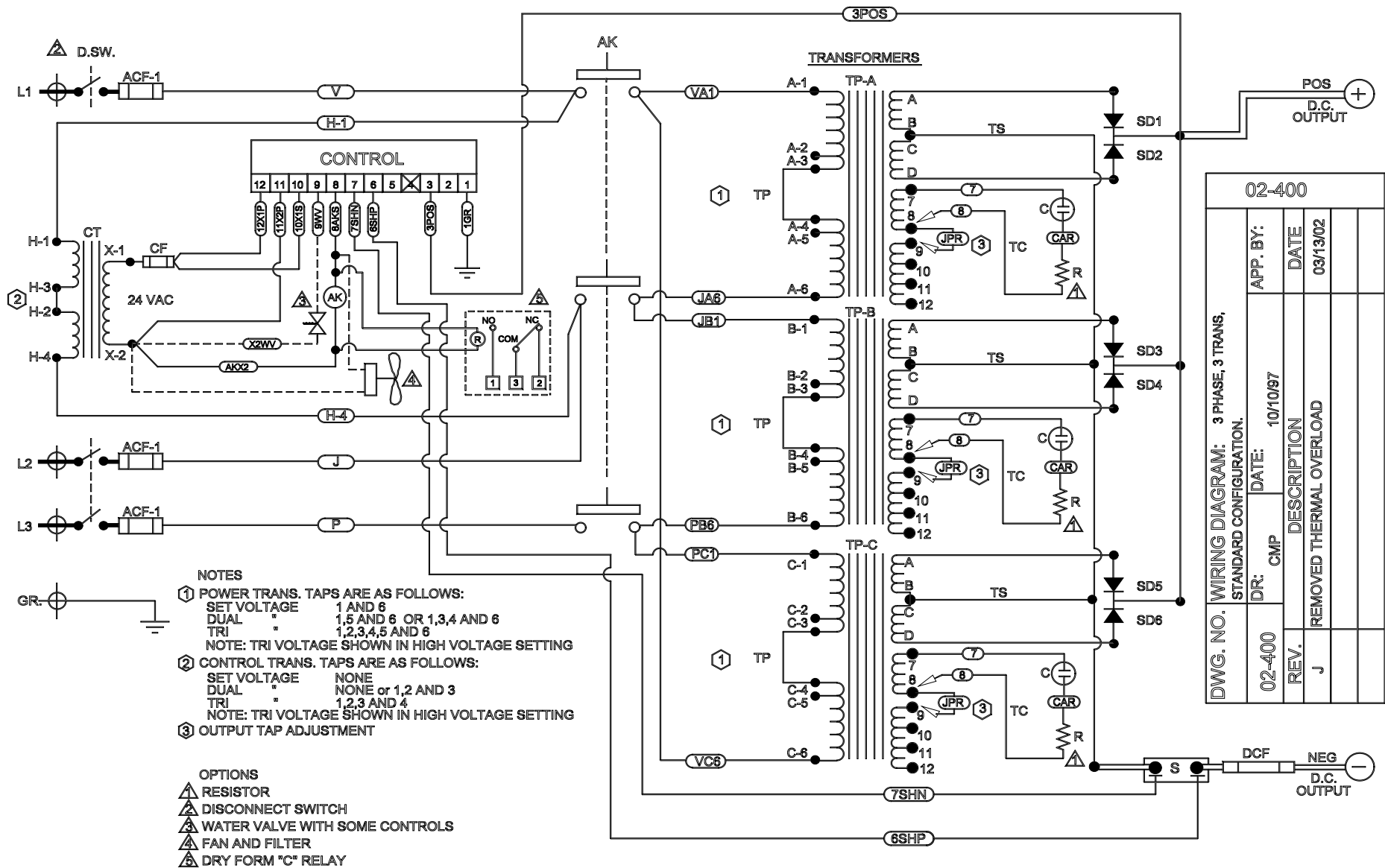

02-400

DWG. NO. WIRING DIAGRAM: 3 PHASE, 3 TRANS, STANDARD CONFIGURATION.		APP. BY:	DATE:
02-400	DR: CMP	10/10/97	
REV. J	DESCRIPTION	REMOVED THERMAL OVERLOAD	
		03/13/02	

Three Phase Charger Schematic # 02-400

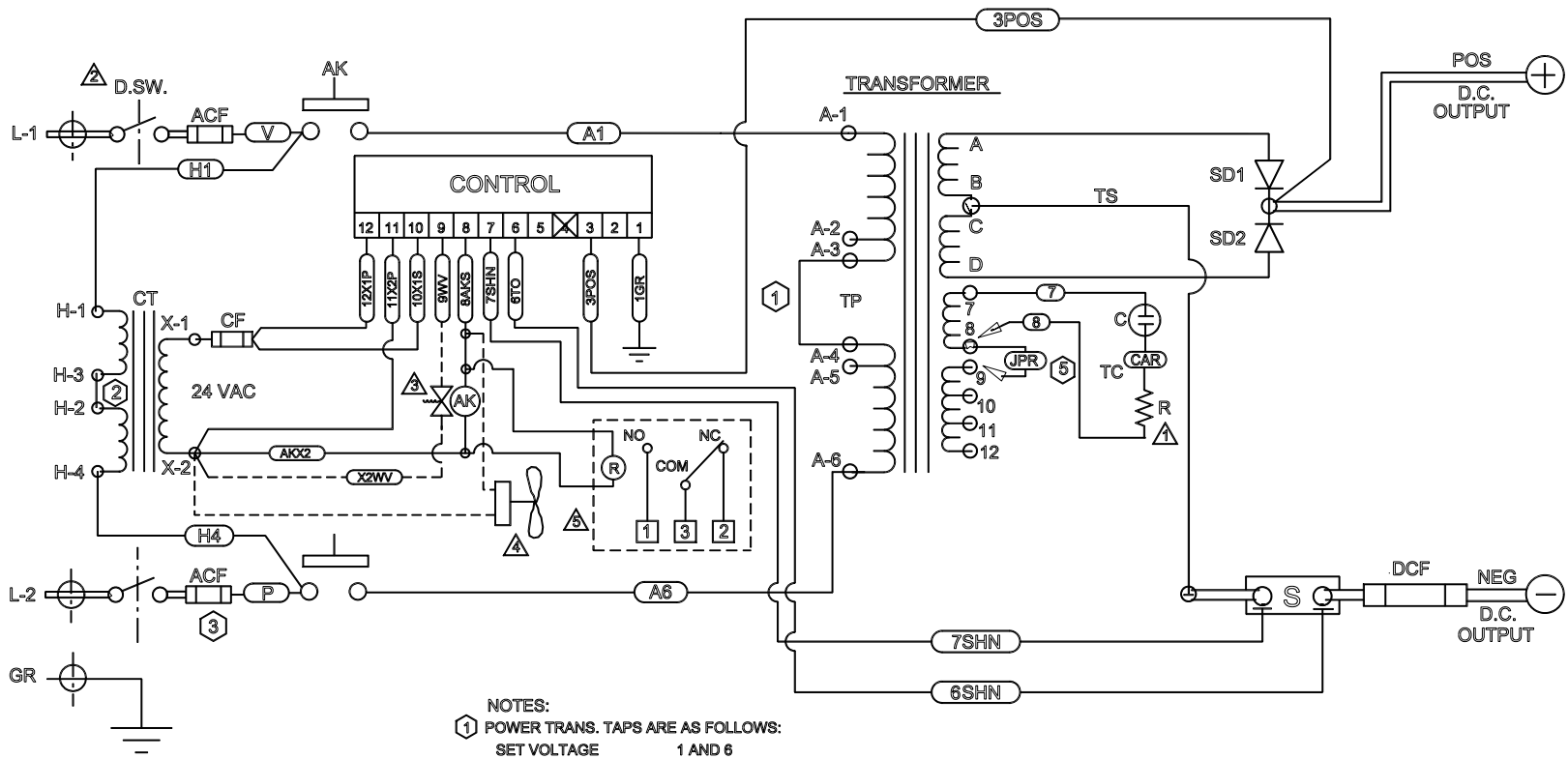

- OPTIONS:**
- ① RESISTOR
 - ② DISCONNECT SWITCH
 - ③ WATER VALVE WITH SOME CONTROLS
 - ④ FAN AND FILTER
 - ⑤ DRY FORM "C" RELAY - OPTIONAL

- NOTES:**
- ① POWER TRANS. TAPS ARE AS FOLLOWS:
 SET VOLTAGE 1 AND 6
 DUAL " 1,5 AND 6
 TRI " 1,2,3,4,5 AND 6
 NOTE: TRI VOLTAGE SHOWN IN HIGH VOLTAGE SETTING
- ② CONTROL TRANS. TAPS ARE AS FOLLOWS:
 SET VOLTAGE NONE
 DUAL " NONE OR 1,2 AND 3
 TRI " 1,2,3 AND 4
 NOTE: TRI VOLTAGE SHOWN IN HIGH VOLTAGE SETTING
- ③ FOR 120V OPERATION, INSTALL A DUMMY FUSE IN LINE 2. CONNECT THE NEUTRAL INPUT LEAD TO LINE 2.
- ④ TRANSFORMER THERMAL OVERLOAD
- ⑤ OUTPUT TAP ADJUSTMENT

DWG. NO.	WIRING DIAGRAM: 1 PHASE, 1 TRANS STANDARD CONFIGURATION.			02-416
02-416	DR: CMP	DATE: 10/15/97	APP'VD BY:	
REV	DESCRIPTION		DATE	
1	REMOVED THERMAL OVERLOAD		3/13/02	

Single Phase Charger Schematic # 02-416