



Installation, Operation, and Maintenance Manual



**Model CSW-2 Wall Mounted
Battery Charger Support**



Storage Battery Systems LLC
N56 W16665 Ridgewood Drive
Menomonee Falls, WI 53051



1. Application

The CSW-2 wall mount bracket is intended to be used in pairs, for the purpose of locating and supporting battery charging equipment with the limitations of 500 lbs gross weight including cabling and retraction components, 24 inches in depth (wall to front extremity), 36 inches in width (bracket pair separation), and 24 inches in height, (footing base to upper extremity), and is not fit for any other purpose.

This bracket configuration is intended to support the weight of one self contained battery charger, cable leads and retractors only, and will not withstand side-to-side loads, moment loads, or stacked loads of any type.

**Caution:**
Weight Capacity for 2 brackets is 500 LBS.
Do Not Exceed Weight Limit

2. Tools Required:

- Assorted Wrenches/Socket
- Electric Drill with Masonry Bit
- Work Gloves (Optional)

3. Parts List

STANDARD EQUIPMENT				
ITEM	DESCRIPTION	QTY	U/R/EA	Part/STOCK NO.
1	Charger Shelf, Wall Type	2		F0017MP
OPTIONAL EQUIPMENT				
2	Mounting Bracket w/Hardware, Cable Retractor	1		F4085
3	Cable Retractor, BCR-58H	1		BCR-58H

- No hardware is included as hardware will vary based on your wall type and material.

4. Installing the Unit

Asymmetrical brackets are left and right hand pairs and must be mounted accordingly. Symmetrical brackets can be mounted either direction universally. Each bracket has holes to accommodate mounting fasteners of 1/2 inch in shank diameter. The type, length and installation method of the fasteners chosen for mounting is dependent on several variables including, but not limited to, the type of wall and strength of the construction materials, imposed dynamic loading such as inadvertent battery movement with the charger cables attached, vibrations or accidental impact from other equipment, and in many areas potential seismic activity.

Consult your in-plant safety personnel and/or engineers for the proper mounting procedures specific to your environment, location, and application.

MTC Engineers are available for a nominal fee to access the strength of your wall and make recommendations for securing your CSW support.

MTC will not be liable for improper or unsafe installations.

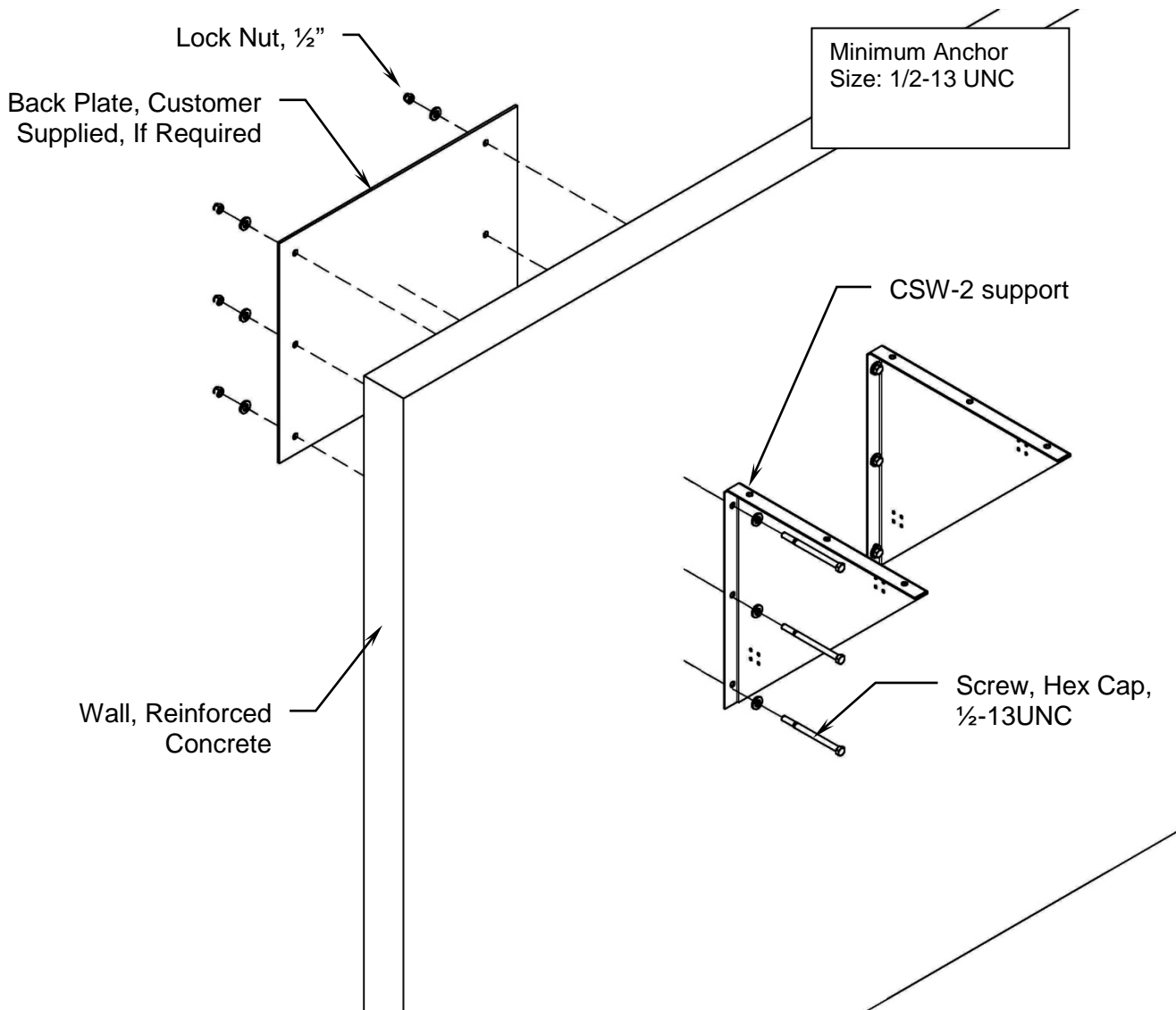

Figure 1. Typical Install, Reinforced Concrete Wall

- Measure Charger Foot Pattern and layout hole pattern on wall accordingly.
- Drill holes; Thru holes for bolts; Tap Drill holes for Lags.
- Secure CSW-2 using required hardware. Use back plate if required.

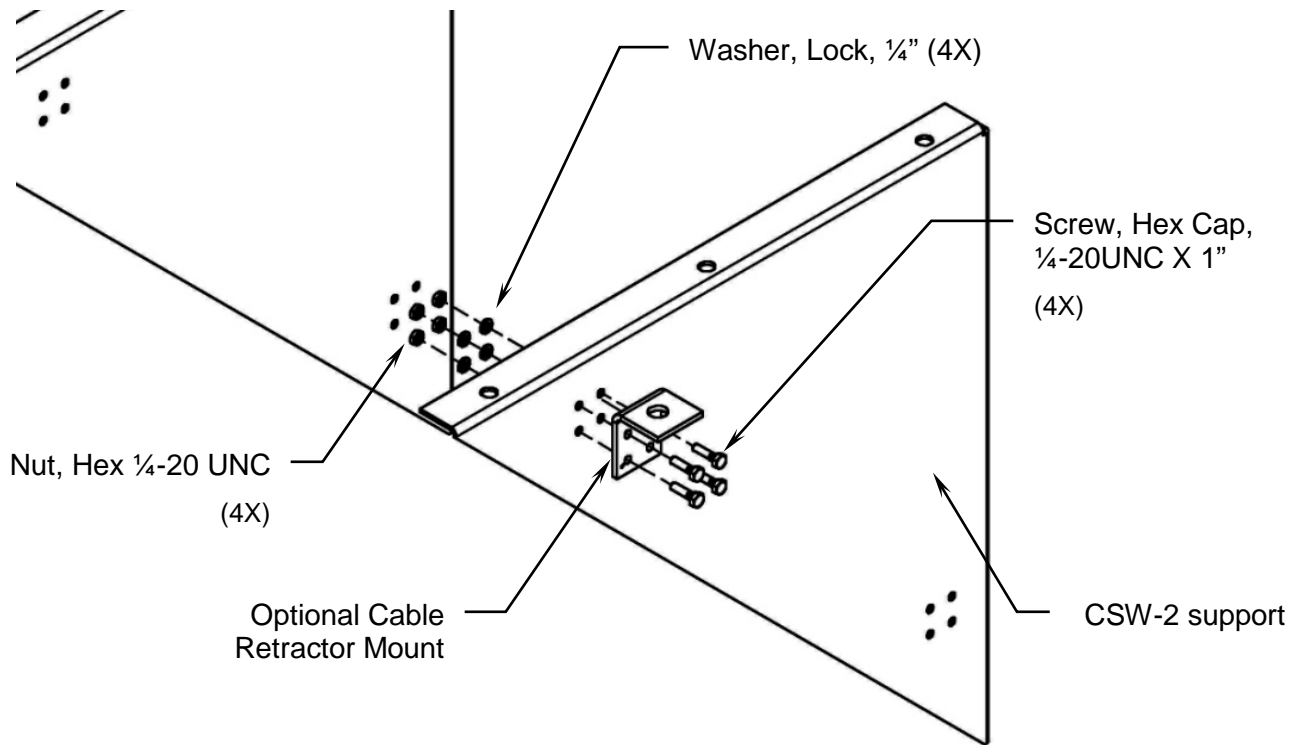

Figure 2. Install Optional Cable Retractor Mount

- d. {OPTIONAL} Secure Cable Retractor Mount to one CSW-2 support using 4 screws (1/4-20 UNC X 1"), 4 flat washer (1/4"), and 4 locknuts (1/4").

 **Caution**

To avoid potential injuries and/or damage to equipment, Battery Charger Supports must be secured to a wall of sufficient strength and thickness to support the load.

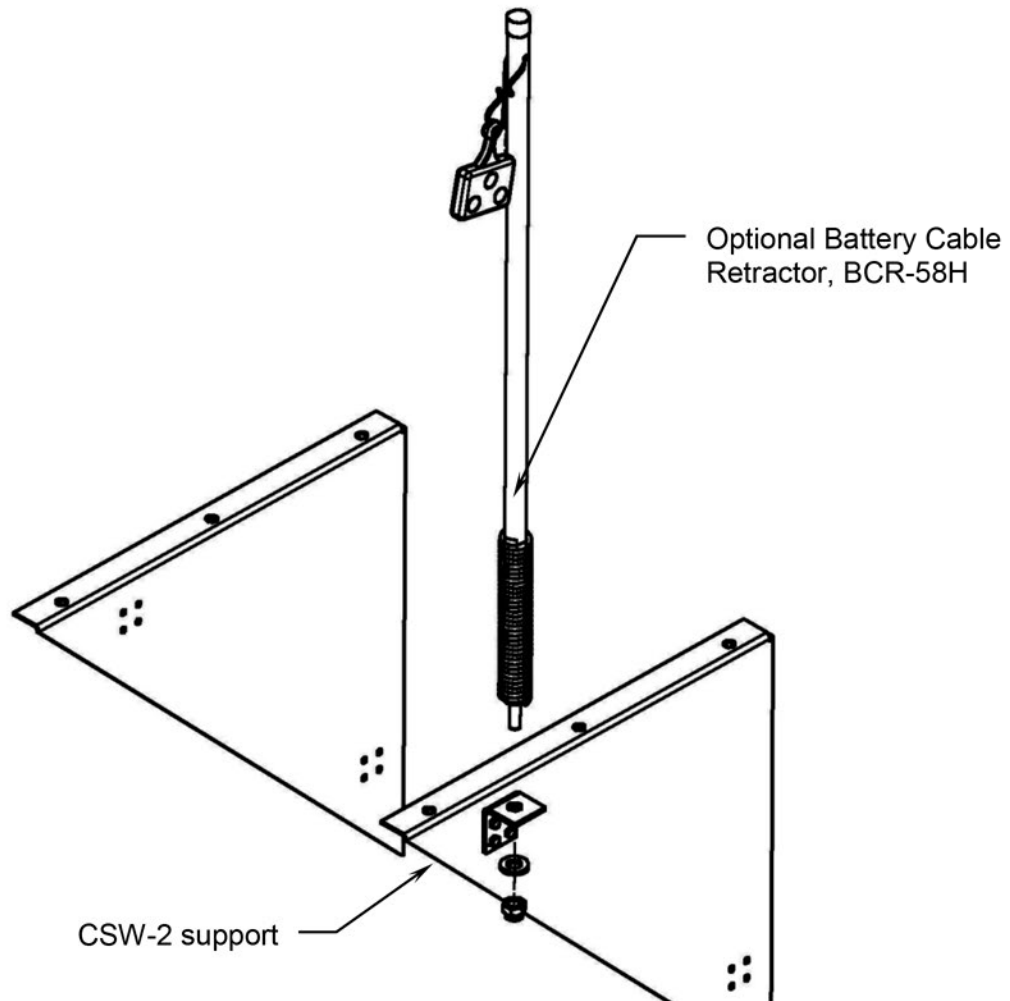

Figure 3. Install Battery Cable Retractor

- e. {OPTIONAL} Attach battery cable retractor, BCR-58H, to battery cable retractor mount.